

Preliminary

# Pirate Loot™ Operation Manual



**WARNING**

Be sure to read this Operation Manual before using your machine to ensure safe operation.

**2012 Bob's Space Racers Incorporated**

427 15<sup>th</sup> Street, Daytona Beach, Florida 32117

**Tel: (386) 677-0761 Fax: (386) 677-0794**

## Table of Contents

### Contents

<b>Specifications .....</b>	<b>4</b>
<b>Package Contents.....</b>	<b>5</b>
<b>Introduction.....</b>	<b>6</b>
<b>Moving the Machine.....</b>	<b>7</b>
<b>Game Play .....</b>	<b>7</b>
<b>Description of Parts.....</b>	<b>8</b>
<b>Player Sensors.....</b>	<b>9</b>
<b>Leveling the Game.....</b>	<b>11</b>
<b>Conveyor Belt Adjustment.....</b>	<b>11</b>
<b>Electrical Power Box .....</b>	<b>12</b>
<b>Game Options .....</b>	<b>13</b>
<b>Option Settings .....</b>	<b>14</b>
<b>Maintenance .....</b>	<b>16</b>
<b>Main Component Instruction.....</b>	<b>16</b>
<b>Ticket Dispenser .....</b>	<b>17</b>
<b>Parts List .....</b>	<b>18</b>
<b>Warranty .....</b>	<b>21</b>
<b>Calling for Service .....</b>	<b>22</b>

## Specifications

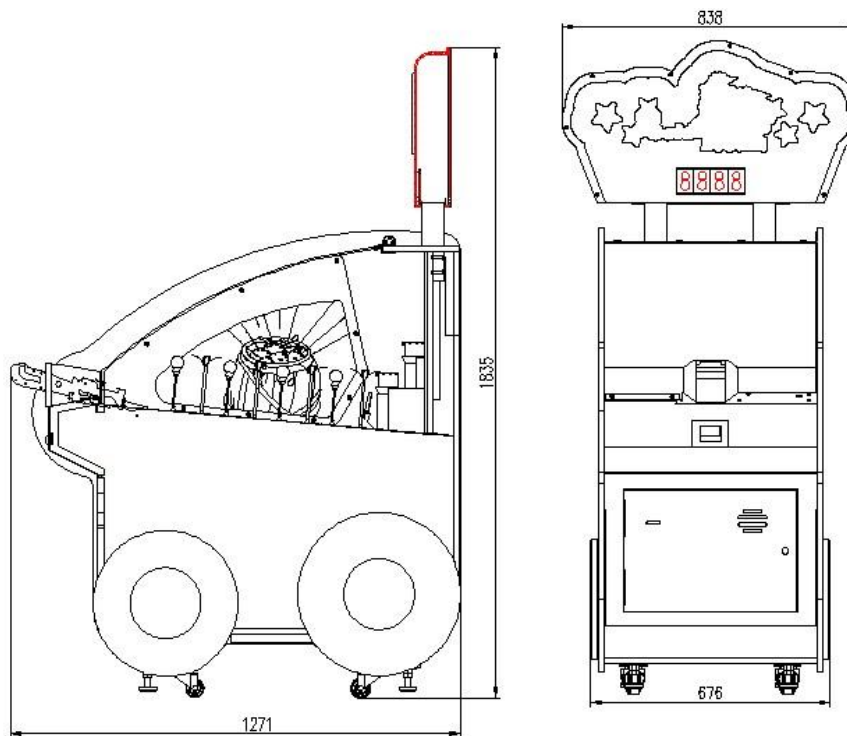

(1) Voltage AC 220V $\pm$ 10% 50Hz $\pm$ 3Hz AC 110V $\pm$ 10% 60Hz $\pm$ 3 Hz

(2) Power 220V 130W MIN 145W MAX  
110V 125W MIN 145W MAX



(3) Size W1271 $\times$ L840 $\times$ H1835 mm

(4) Environment indoor temperature -10 +40 Humidity  $\leq$ 90% Pressure 86Pa 106Pa;

(5).Weight About 120 kg

## Package Contents

### Game Unit Accessories

NO	PART NAME	REGULATION	QTY	UNIT	PICTURE	NOTE
1	Power Cable	1.5m	1	PCS		
2	Fuse	Φ5-20mm/6.3A	1	PCS		
3	Manual		1	PCS		
4	Key	X919	2	PCS		Front door
		X818	1	PCS		Coin door
5	Sensor	H type	1	PCS		Scoring detecting
6	Sleeve	14mm	1	PCS		Use for adjusting belt

Note: Any information subject to change without prior notice.

## Introduction

Overview:

Thank you for purchasing the new Pirate Loot™ from Bob's Space Racers®. Built on a long tradition of value, the new Pirate Loot™ retains all of the great game play you have come to expect of a game from BSR, and is specifically designed for today's Arcade environment. The new game uses technology specifically developed for this application.

This owner's Manual is intended to provide detailed descriptions together with all the necessary information covering the general operation of electronic assemblies, servicing control, spare parts, etc. pertaining to the game.

This manual is intended for the owner, personnel and managers in charge of operation of the product. Operate the product after carefully reading and sufficiently understanding the instructions. If the product fails to function satisfactorily, non-technical personnel should under no circumstances touch the internal system.

To Maintain Safety:

To ensure the safe usage of the product, be sure to read the following before using the product. The following instructions are intended for the users, operators and the personnel in charge of the operation of the product. After carefully reading and sufficiently understanding the warning display and cautions, handle the product appropriately. Be sure to keep this operation manual nearby the product or elsewhere convenient for referring to it when necessary.

Herein, explanations which require special attention are in sign of warning. Depending on the potentially hazardous degrees, the terms of NOTICE, WARNING, and CAUTION, etc. are used. Be sure to understand the content of the displays before reading the text.

WARNING: (or) CAUTION:

Disregarding this text could result in serious injury or damage to the machine.

**WARNING:** To Avoid  
Risk of Shock, Refer Service  
To Qualified Personnel.

**WARNING:**  
This Part May Have A High Voltage  
Present. Disconnect Power From  
Equipment Before Servicing.

NOTE (or) NOTICE:

**NOTE: ONLY QUALIFIED TECHNICAL PERSONNEL SHOULD WORK ON THIS GAME. FAILING TO COMPLY CAN CAUSE SEVERE INJURY.**

## Moving the Machine

It is required to wrap the machine with soft cushion, pack or air bundle the machine when carrying in long-distance to avoiding crushing.

### Warning

- **Turn off the machine and unplug power cable before moving.**
- **Make sure all casters are intact**
- **Slide the machine on the even floor**
- **Ensure the game is level before connecting the power.**

## Game Play

Insert coin into coin mech slot, aim the coin at the score pillars; once the coin enters into any of the six (6) Score Pillars, the player will win the tickets shown on the corresponding Pillar display. If the coin enters into the moving "Bonus Ticket" Pillar, the player will win the amount of tickets displayed in the "BONUS TICKET" display.

## Description of Parts

FRONT

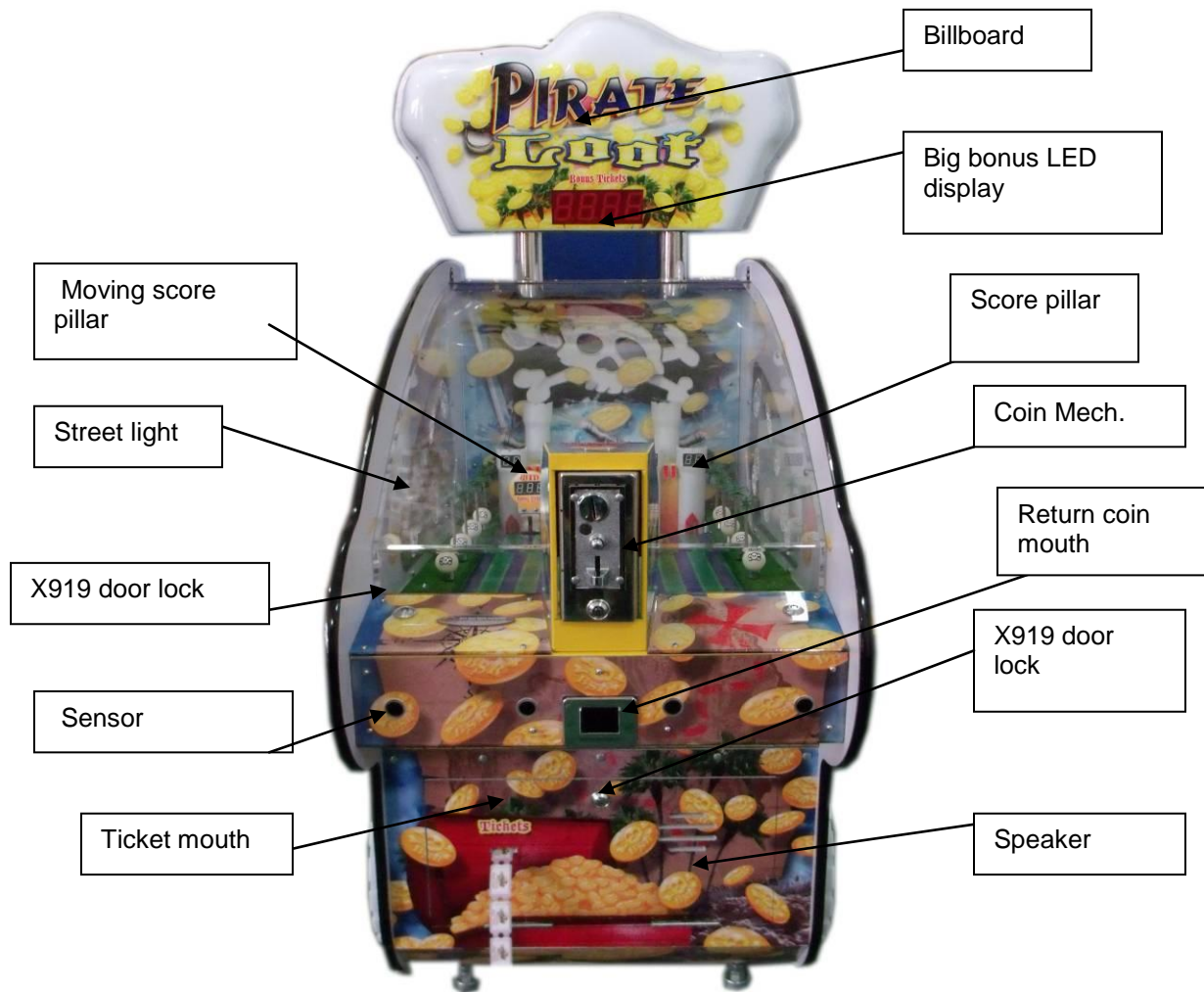

The ticket value showing on BONUS TICKET display on the Billboard is the bonus tickets, as well as showing on the Moving Score Pillar display  
 The BONUS TICKET display displays “HELP” and the quantity of owed tickets when the ticket dispenser is out of tickets.

## Player Sensors

As shown below, there are 4 sensors installed on the machine at the front control panel. This is the detecting area.

When people come near the machine and enter into the detecting area, the Moving Score Pillar will move left and right automatically for the players to start the game.

If no one is in the detecting area, the Rolling Mechanism and Score Pillar Moving Mechanism will not function.

There are six Score Pillars including one Moving Score Pillar as shown below.

The ticket value shown on each display can be set according to the IO chart. The setting of Score 1 and Score 5 is the same as well as the Score 2 and Score 4.

Score 3 has an independent value setting.





The value displayed on the moving display is the bonus tickets amount.

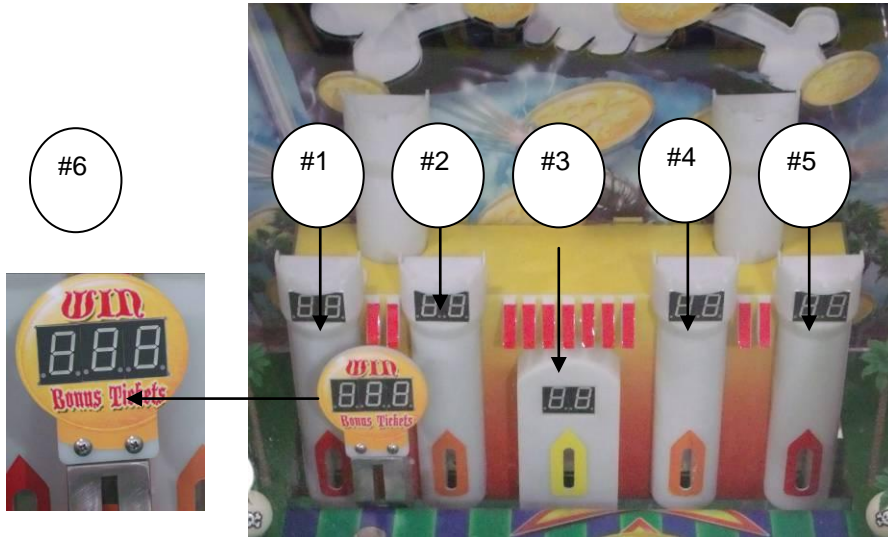

Once a coin enters into the Moving Bonus Tickets Pillar, all the lights will flash and the player will win the Bonus Tickets.

BACK

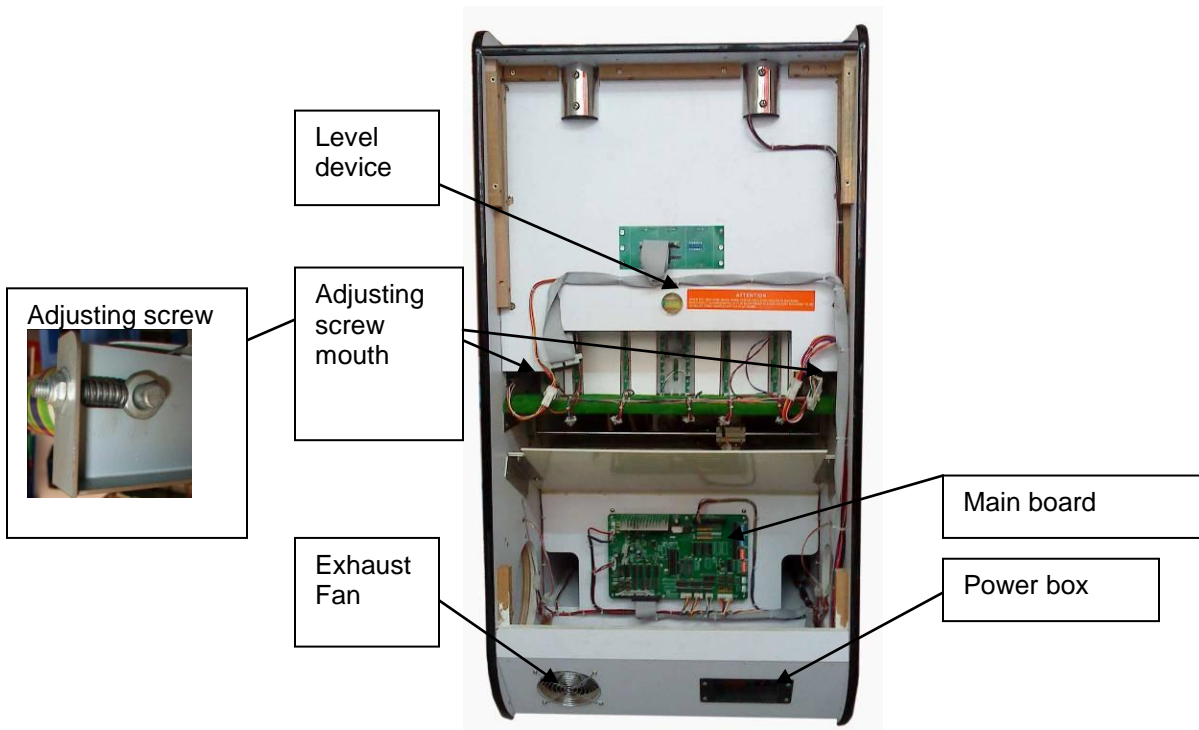

## Leveling the Game

Install this machine on a flat surface. Adjust levelers to lift the legs and level game.

**The Game will only operate when it is level.**

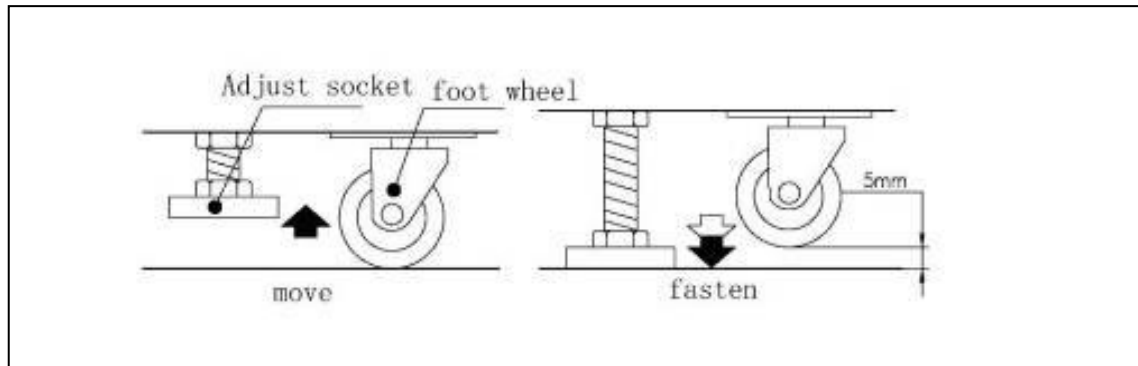

## Conveyor Belt Adjustment

Make sure the machine is level. If the belt is not tracking in the correct position, then it is possible the machine is out of level. Adjust the level and let the belt run at least one hour to correct the belt tracking. If the belt is still not tracking correctly, then the operator should adjust the two side screws until the belt is tracking correctly.

Method for Adjusting Belt:

- Adjust spring length to change the belt tightness;
- Power off the machine and open the back door.
- Place your hand under the belt and press the belt so as to test the belt's tightness.

## Belt Tracking Adjustment

1. If belt is tracking to the Right, then tighten the screw at Right side.
2. If belt is tracking to the Left, then tighten the screw at Left side.

- After correcting the belt tracking, please check whether the belt is too tight or too loose. If the belt is too tight, please loosen the 2 screw on both sides, if the belt is too loose, tight screws on the both sides.
- Fasten the screws when the adjustment is completed.

## Electrical Power Box

AC 220V/110V $\pm$ 5% 60Hz; 230V~220V 110V-120V

AC fuse 110V/220V 6.3A  $\phi$ 6mm

Electricity switch use to open or close power

Connect ground end connect ground wire

Connect hole connect machine

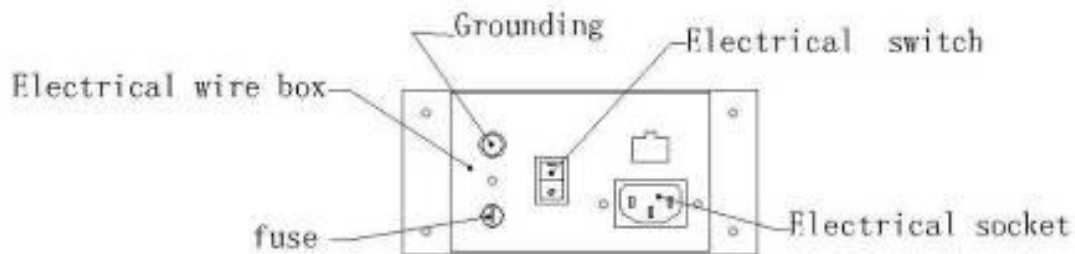

## Game Options

- (1). Check I/O Sheet for option settings.
- (2). DIP Switches are labeled SW1 thru SW4 as shown in the PCB layout below.

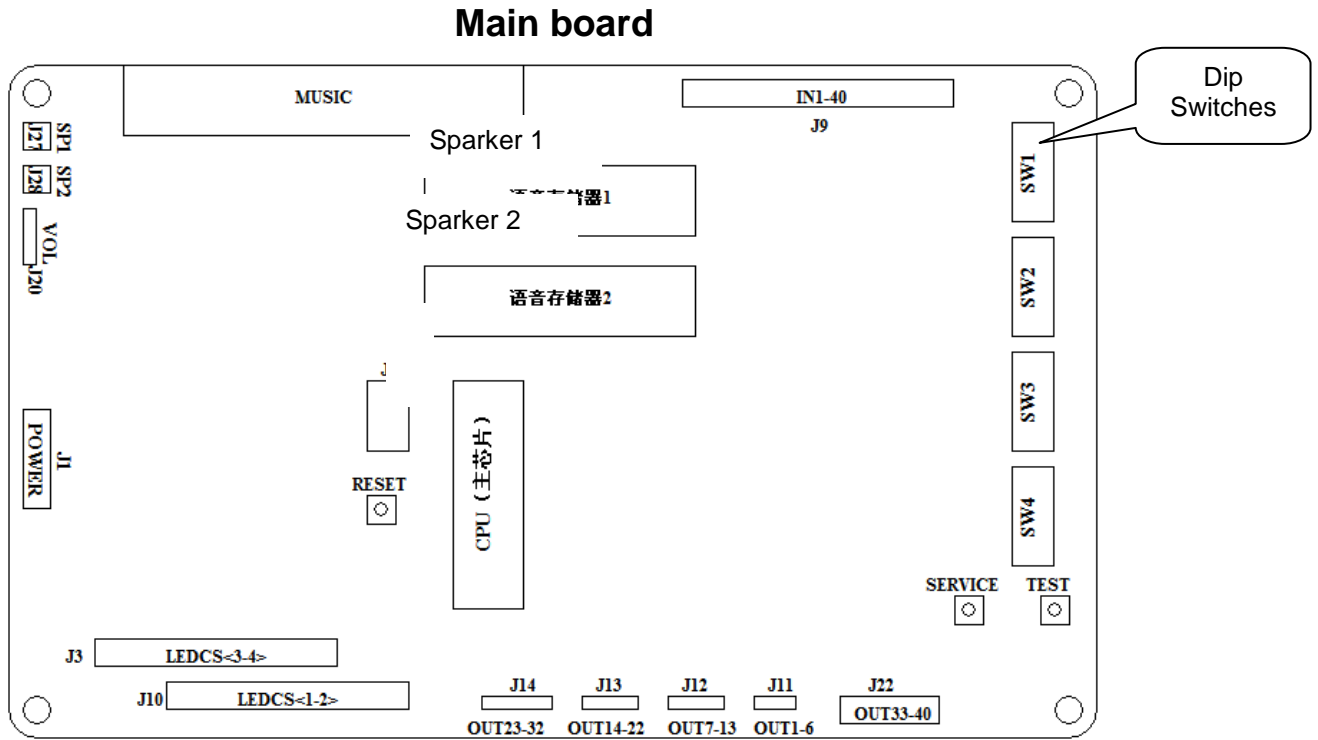

### Option Settings

Default Settings are **BOLD**.

Item	Des.	SW1							
		1	2	3	4	5	6	7	8
Coin(s)/JP Adding a	0	on	on						
	<b>1</b>	<b>OFF</b>	<b>ON</b>						
	2	on	off						
	3	off	off						
Demo	on				on				
	<b>OFF</b>				<b>off</b>				
JP Start Value (Moving Target)	0					on	on	on	on
	5					off	on	on	on
	10					on	off	on	on
	15					off	off	on	on
	20					on	on	off	on
	25					off	on	off	on
	30					on	off	off	on
	50					off	off	off	on
	<b>75</b>					<b>ON</b>	<b>ON</b>	<b>ON</b>	<b>OFF</b>
	100					off	on	on	off
	150					on	off	on	off
	200					off	off	on	off
	250					on	on	off	off
500					off	on	off	off	
750					on	off	off	off	
1000					off	off	off	off	

Item	Des.	SW2							
		1	2	3	4	5	6	7	8
Payout	<b>Y</b>	<b>ON</b>							
	N	off							
Mini Ticket Payout	0			on	on				
	<b>1</b>			<b>OFF</b>	<b>ON</b>				
	2			on	off				
	4			off	off				
Max. Bonus Payout	No Limited					on	on	on	
	25					off	on	on	
	50					on	off	on	
	100					off	off	on	
	200					on	on	off	
	<b>250</b>					<b>OFF</b>	<b>ON</b>	<b>OFF</b>	
	500					on	off	off	
	1000					off	off	off	

Item	Des.	SW3							
		1	2	3	4	5	6	7	8
#1 and #5 Ticket Value	2	on	on	on	on				
	3	off	on	on	on				
	4	on	off	on	on				
	5	off	off	on	on				
	6	on	on	off	on				
	8	off	on	off	on				
	10	<b>ON</b>	<b>OFF</b>	<b>OFF</b>	<b>ON</b>				
	12	off	off	off	on				
	15	on	on	on	off				
	20	off	on	on	off				
	25	on	off	on	off				
	30	off	off	on	off				
	40	on	on	off	off				
	50	off	on	off	off				
60	on	off	off	off					
75	off	off	off	off					
#2 and #4 Ticket Value	4					on	on	on	on
	5					off	on	on	on
	6					on	off	on	on
	8					off	off	on	on
	10					<b>ON</b>	<b>ON</b>	<b>OFF</b>	<b>ON</b>
	12					off	on	off	on
	15					on	off	off	on
	20					off	off	off	on
	25					on	on	on	off
	30					off	on	on	off
	40					on	off	on	off
	50					off	off	on	off
	60					on	on	off	off
	75					off	on	off	off
100					on	off	off	off	
125					off	off	off	off	

Item	Des.	SW4							
		1	2	3	4	5	6	7	8
#3 Ticket Value	2	on	on	on	on				
	3	off	on	on	on				
	4	on	off	on	on				
	5	off	off	on	on				
	6	on	on	off	on				
	8	off	on	off	on				
	10	on	off	off	on				
	12	off	off	off	on				
	15	on	on	on	off				
	20	<b>OFF</b>	<b>ON</b>	<b>ON</b>	<b>OFF</b>				
	25	on	off	on	off				
	30	off	off	on	off				
	40	on	on	off	off				
	50	off	on	off	off				
60	on	off	off	off					
75	off	off	off	off					

## Maintenance

Due to the design of the machine, very little periodic maintenance is required.

Start the game and verify the correct operation before putting the game into everyday operations.

Clean the surface of the game as needed.

After about a month of game operation, check to be sure all parts are secure and in proper working order.

### 1. Remove power before servicing game.

To avoid a short circuit, the power must be removed before touching the inside of the game.

### 2. Choose the appropriate replacement parts.

Using the wrong parts could lead to malfunction or damage to the game and components.

### 3. Do not substitute or change equipment, without authorization.

Doing so could lead to a short circuit and machine malfunction, or fire.

### 4. Do not put containers of water, cups or soda cans on the machine. In addition, chemicals or heavy items should not be allowed around the game.

The spill could cause a short circuit. Falling items could injure people or destroy the machine.

## Main Component Instruction

### Mechanical Coin Selectors D-200

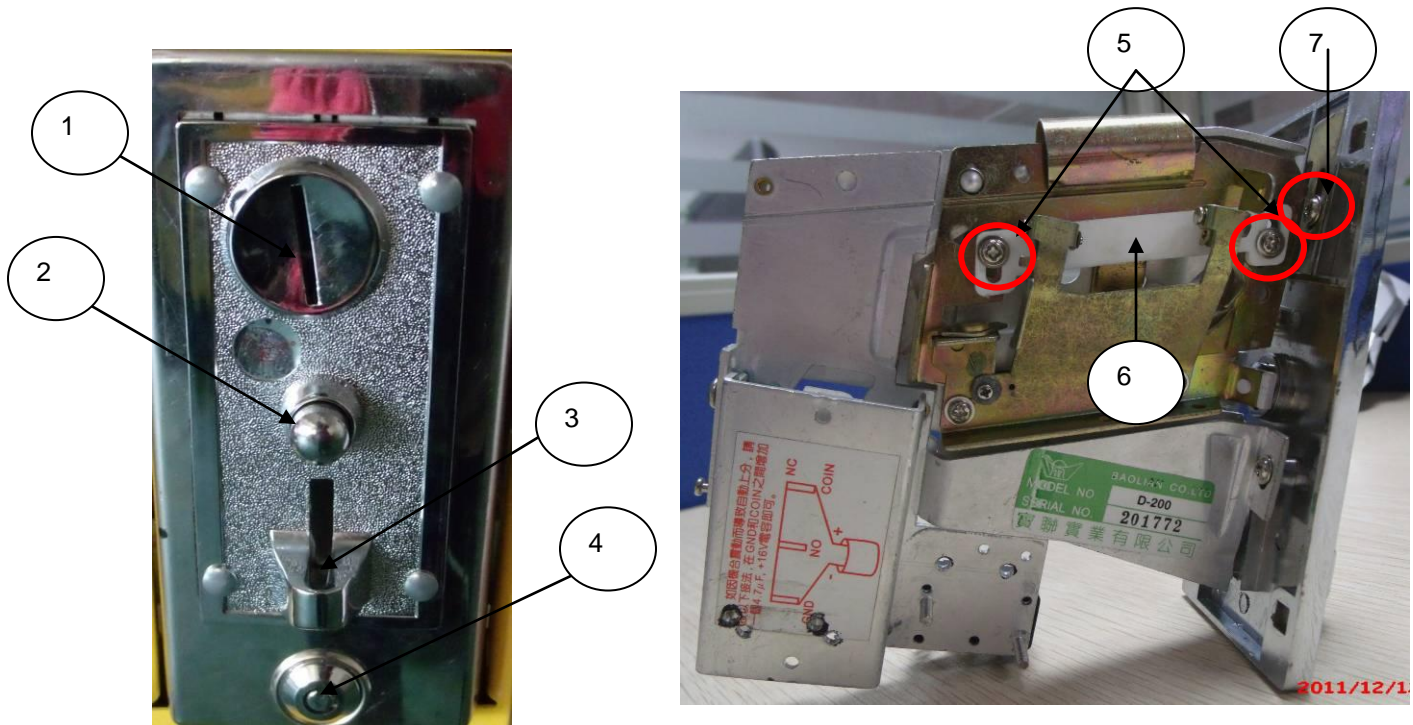

1 Coin Insert 2 Reject button 3 Coin Reject 4 X818 Lock  
5 Adjusting Screws 6 Coin Adjusting Bar 7 Screws

Insert coin when game starts.

If coin jams, press the Reject Button once, and the jammed coin will come out. If not, take apart the coin Mech to remove coin.

Adjust the coin selector by the adjusting screws. Unscrew the adjusting screws, move the coin adjusting bar upwards and downwards according to the dimension of the correct coin.

## Ticket Dispenser

Installing ticket instruction

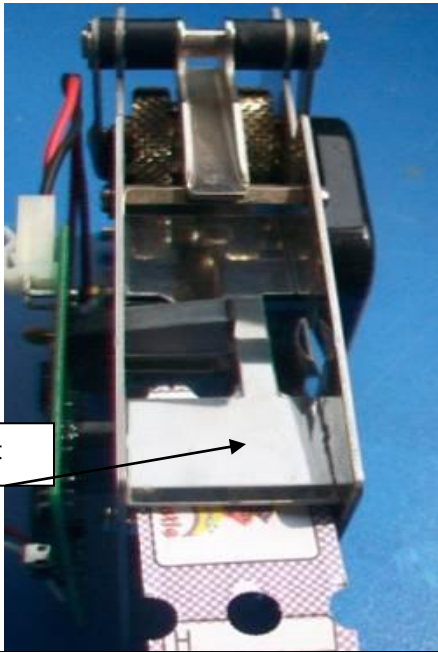

Ticket slot

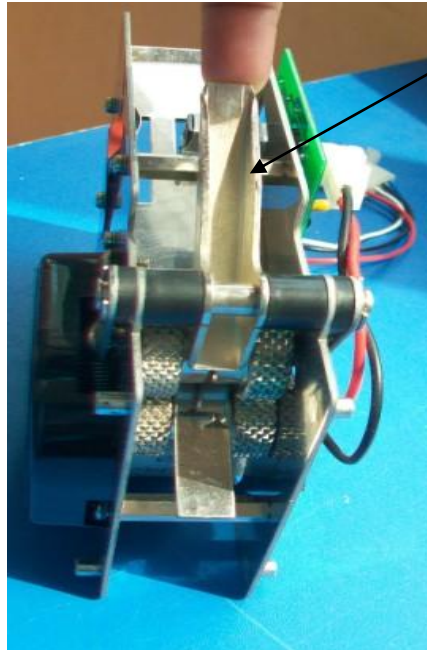

Clamping roller lever



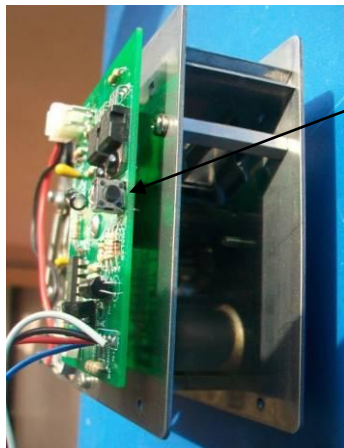





Insert ticket from Ticket slot. When tickets reach the wheel, push up the Clamping roller lever to insert tickets.









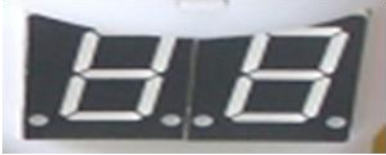

Testing button: Press testing button to check whether the ticket dispenser work normally or not after insert the tickets.



**Parts List**

Description	Image
Main Board	
Top Sign	
Lamp on Top Sign	
Top Sign Display	
Side Window	
Mechanical Coin Mech Assembly	
Plexiglas Cover	
Black Wall	

<p>Castle Assembly Completely</p>	
<p>Score Display on Castle</p>	
<p>Moving Bonus Target assembly complete</p>	
<p>Motor for Moving Bonus Target</p>	
<p>Scoring High Sensor</p>	
<p>Wheel assembly complete</p>	
<p>LED on wheel</p>	
<p>Belt Motor</p>	
<p>Detector on control panel</p>	
<p>Speaker</p>	

<p>Power Box</p>	
<p>Fan</p>	
<p>Belt for Table</p>	

## Warranty

# BOB'S SPACE RACERS INC. 90 DAY COIN-OPERATED GAME WARRANTY

1. INCLUDED IN THIS WARRANTY Bob's Space Racers®, Inc. warrants to the original purchaser only that the equipment that is the subject of this sale conforms to its specifications, and is free from defects under normal service for a 90 day period from the original date of deliver. This warranty does not include any damages resulting from occurrences listed in paragraph 2 below. This warranty is not transferable under any circumstance. Any claims under this warranty must be received in writing by Bob's Space Racers®, Inc. within 120 days from date of delivery. Within a reasonable time of such written notification Bob's Space Racers®, Inc. will replace or repair any defective component of the equipment or part thereof which fails for reasons other than normal service, use, or wear. Bob's Space Racers®, Inc. reserves the right to request dated proof of purchase by the end user (original purchaser) at any time. Light bulbs are specifically excluded from this warranty and shall be the sole responsibility of the purchaser. Bob's Space Racers®, Inc., within its sole discretion, makes the final determination as to whether to repair or replace any component and whether any such repair or replacement shall be performed where the equipment is located or at it's home facility in Volusia County, Florida, or another facility of its sole choice. Any and all freight charges for the purposes of repair or replacement shall be paid by the original purchaser. All defective parts shall be returned to Bob's Space Racers®, Inc. if requested. Bob's Space Racers®, Inc. does not warrant that the equipment will meet any original purchaser's specific requirements or that the operation of the equipment will be uninterrupted. These remedies are the original purchaser's exclusive remedies for breach of warranty.

2. EXCLUDED BY THIS WARRANTY Bob's Space Racers®, Inc. does not warrant (a) any product, components or parts not manufactured by Bob's Space Racers®, Inc.; (b) damages caused by use of the equipment for purposes other than those for which it was designed; (c) defects caused by failure to provide a suitable installation environment for the equipment; (d) damage caused by unauthorized attachments, modification, or service; (e) damage caused by normal wear and tear or improper power supply; (f) damage caused by accident or disaster such as fires, flood, lightning, and wind; or (g) any other abuse or misuse of the equipment.

3. EXCLUSIVE WARRANTY. THE FORGOING WARRANTY IS EXCLUSIVE AND IN LIEU OF ALL OTHER WARRANTIES OR REMEDIES, WHETHER WRITTEN, ORAL OR IMPLIED. THERE ARE NO WARRANTIES WHICH EXTEND BEYOND THE DESCRIPTION ON THE FACE HEREOF. ANY AND ALL IMPLIED WARRANTIES OF MERCHANTABILITY, FITNESS FOR A PARTICULAR PURPOSE, COURSE OF DEALING OR USAGE OF TRADE ARE HEREBY EXPRESSLY DISCLAIMED AND EXCLUDED.

4. REMEDIES LIMITED. UNDER NO CIRCUMSTANCES, EXCEPT TO THE EXTENT PROHIBITED BY APPLICABLE LAW, SHALL BOB'S SPACE RACERS®, INC. BE LIABLE FOR ANY LOSS OR DAMAGE, DIRECT OR INDIRECT, SPECIAL INCIDENTAL OR CONSEQUENTIAL ARISING OUT OF THE USE OR INABILITY TO USE THIS EQUIPMENT INCLUDING BUT NOT LIMITED TO ANY CLAIM FOR LOSS OR PROFITS, LOSS OF SAVINGS OR REVENUE, LOSS OF USE OF THE EQUIPMENT, OR ANY ASSOCIATED EQUIPMENT, FACILITIES OR SERVICE, DOWNTIME, THE CLAIMS OR COSTS OF THIRD PARTIES INCLUDING CUSTOMERS AND INJURY TO PROPERTY. Some states do not allow limitations on how long an implied warranty lasts or the exclusion or limitation of incidental or consequential damages, so the above limitations or exclusion may not apply to you. This warranty gives you specific legal rights, and you may also have other rights which vary from state to state.

5. NO OTHER WARRANTIES. Unless modified in writing and signed by both parties, this agreement is understood to be the complete and exclusive agreement between the parties, superseding all prior agreements, oral or written, and all other communications between the parties relating to the subject matter of this agreement. No employee or representative of Bob's Space Racers®, Inc. or any other party is authorized to make any other warranty or to assume any other liability in connection with the sale of its equipment.

6. TIME LIMIT FOR CLAIMS. Any claim for breach of warranty or claims under this warranty must be received in writing by Bob's Space Racers®, Inc. within 120 days following delivery of the equipment.

7. FUTURE CHANGES. Bob's Space Racers®, Inc. reserves the right to reserve, change or modify the construction and design of its equipment or any component part or parts thereof without incurring the obligations to make such changes or modifications in present equipment.

8. ALLOCATION OF RISKS. This agreement allocates the risks of equipment failure between Bob's Space Racers®, Inc. and the original purchaser. This allocation is recognized by both parties and is reflected in the price of the goods. THE PURCHASER ACKNOWLEDGES THAT HE HAS READ THIS AGREEMENT, UNDERSTANDS IT, AND IS BOUND BY ITS TERMS.

9. TO OBTAIN WARRANTY SERVICE. The original purchaser must, at his/her own expense, bring or ship the equipment to an authorized location for service. Additionally, the original purchaser must pay all freight, shipping or transportation charges for the return of the equipment from Bob's Space Racers®, Inc. to the original purchaser. Telephone or write:

Bob's Space Racers®, Inc.  
427 15<sup>th</sup> Street  
Daytona Beach, FL 32117  
Telephone number: 386/677-0761  
FAX: 386/677-0794

## Calling for Service

1. When calling for service, please check the service manual first. Many times the answer to your problem has been addressed in this documentation.
2. Please make sure you have the serial number of the game ready when you call.
3. If this is a repeat call, please tell the service technician that you have made a previous call regarding this problem. This way we will be able to retrieve the history on your game allowing us to serve you better and save you time.
4. Please retain proof of purchase for your product. This might be requested for warranty repairs.
5. Please call from the game if possible since we might need you to check certain things on the game while we are on the telephone with you.

IF YOU HAVE ANY QUESTIONS OR COMMENTS, PLEASE CALL OUR SERVICE DEPARTMENT AT

**(386) 677-0761**

**(MONDAY – FRIDAY, 8:30AM – 5:00PM EST, EXCLUDING HOLIDAYS)**

(or)

**EMAIL QUESTIONS TO: [Tech@BobsSpaceRacers.com](mailto:Tech@BobsSpaceRacers.com)**

(or)

**VISIT THE “CUSTOMER SUPPORT” SECTION ON OUR WEBSITE:  
[WWW.BOBSSPACERACERS.COM](http://WWW.BOBSSPACERACERS.COM)**