



Whack N Win Service Manual

Innovative Concepts in Entertainment, INC

10123 Main Street
Clarence, NY 14031

WWW.ICEGAME.COM

(716) 759-0360 I.C.E. Tech Support

Table of Contents

Safety and Warnings	3
Game Assembly	4 - 8
Programming	9
Tower Score Charts	10
Sensitivity Calibration	11
Service	
Upper Marquee Access	12
Changing Tower Score Values	13
Power Supply	14
Piezo Assembly replacement	
Tower Lighting	15
Spare Parts List	16
Warranty	17

SAFETY AND WARNINGS BEFORE YOU BEGIN

WARNING: WHEN INSTALLING THIS GAME, A GROUNDED A.C. RECEPTACLE MUST BE USED. FAILURE TO DO SO COULD RESULT IN INJURY TO YOURSELF OR OTHERS. FAILURE TO USE A GROUNDED RECEPTACLE COULD ALSO CAUSE IMPROPER GAME OPERATION, OR DAMAGE TO THE ELECTRONICS.

NOTE: THIS GAME IS INTENDED FOR INDOOR USE ONLY.

DO NOT DEFEAT OR REMOVE THE GROUNDING PRONG ON THE POWER CORD FOR THE SAME REASON AS GIVEN ABOVE. USING AN IMPROPERLY GROUNDED GAME COULD VOID YOUR WARRANTY.

HAVE A QUALIFIED ELECTRICIAN CHECK YOUR A.C. RECEPTACLE TO BE SURE THE GROUND IS FUNCTIONING PROPERLY.

THIS GAME IS DESIGNED TO DISSIPATE STATIC ELECTRICITY THROUGH THE GROUNDING PLANE OF THE GAME. IF THE A.C. GROUND DOES NOT WORK, THE GAME COULD DISCHARGE STATIC ELECTRICITY THROUGH THE GAME CIRCUITRY, WHICH COULD CAUSE DAMAGE.

THE POWER SUPPLY IS NOT VOLTAGE ADJUSTABLE. TO OPERATE THE GAME AT VOLTAGES OTHER THAN THOSE IT WAS DESIGNED FOR. PLEASE CONTACT OUR SERVICE DEPARTMENT FOR VOLTAGE CONVERSION INFORMATION.

WARNING

DO NOT remove any of the components on the main board (e.g. compact flash and EPROMS) while the game is powered on. This may cause permanent damage to the parts and the main board. Removing any main board component part while powered on will void the warranty.

ALWAYS REMOVE POWER TO THE GAME, BEFORE ATTEMPTING ANY SERVICE, UNLESS NEEDED FOR SPECIFIC TESTING. FAILURE TO OBSERVE THIS PRECAUTION COULD RESULT IN SERIOUS INJURY TO YOURSELF OR OTHERS.

THIS GAME IS NOT SUITABLE FOR INSTALLATION IN AN AREA WHERE A WATER JET COULD BE USED.

This appliance is not intended for use by persons (including children) with reduced physical, sensory or mental capabilities, or lack of experience and knowledge, unless they have been given supervision or instruction concerning use of the appliance by a person responsible for their safety. Children should be supervised to ensure that they do not play with the appliance.

The game's foot print is 42.5" w x 48" d x 136" h

AC Power Information

The games main fuse is accessed through the back of the game at the power mod. Above the power cord is a small panel that contains the main fuse. The value of the fuse for 120 volt users is 3 AMPS at 250Volt type slow blow. The value of the fuse for 230 users is 1.5 AMPS at 250Volt type slow blow.

Step 1:

Open bottom access panel to expose main board. Remove lower light housing panel to access wiring. Remove the upper light housing panel.

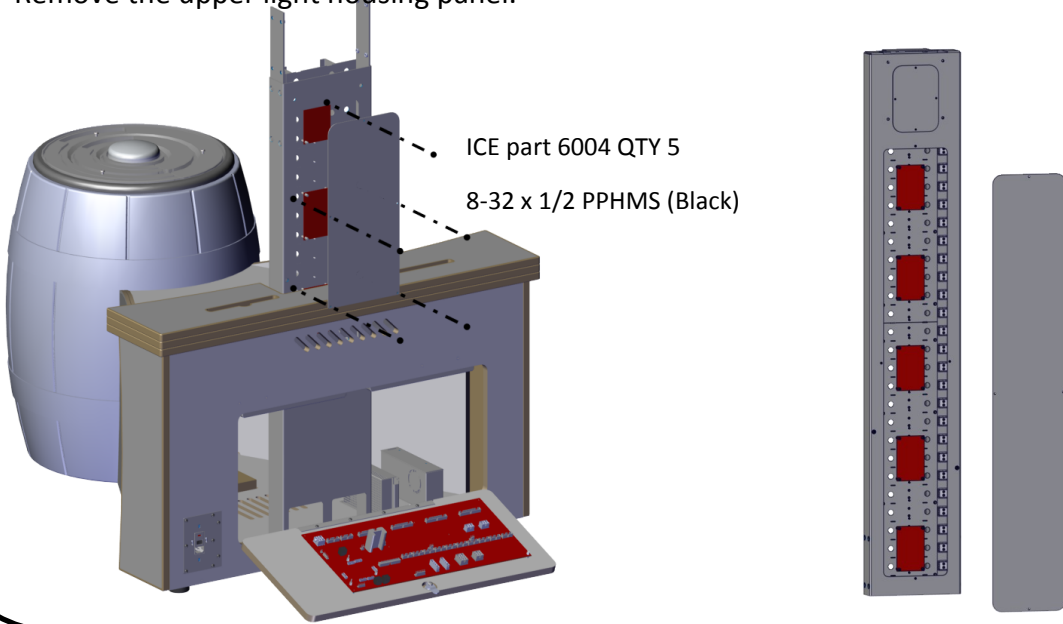

Step 2:

Install 2 1/4—20 x 1 1/4 bolts half way in the light housing's guide tabs as shown with short arrows. Slide the light housing onto the base and stop and rest the tower on the 1/4-20 bolts. This will allow a space for you to work in running the wiring through to the cabinet base. Don't worry about the wiring at this time, just be careful not to pinch the harness.

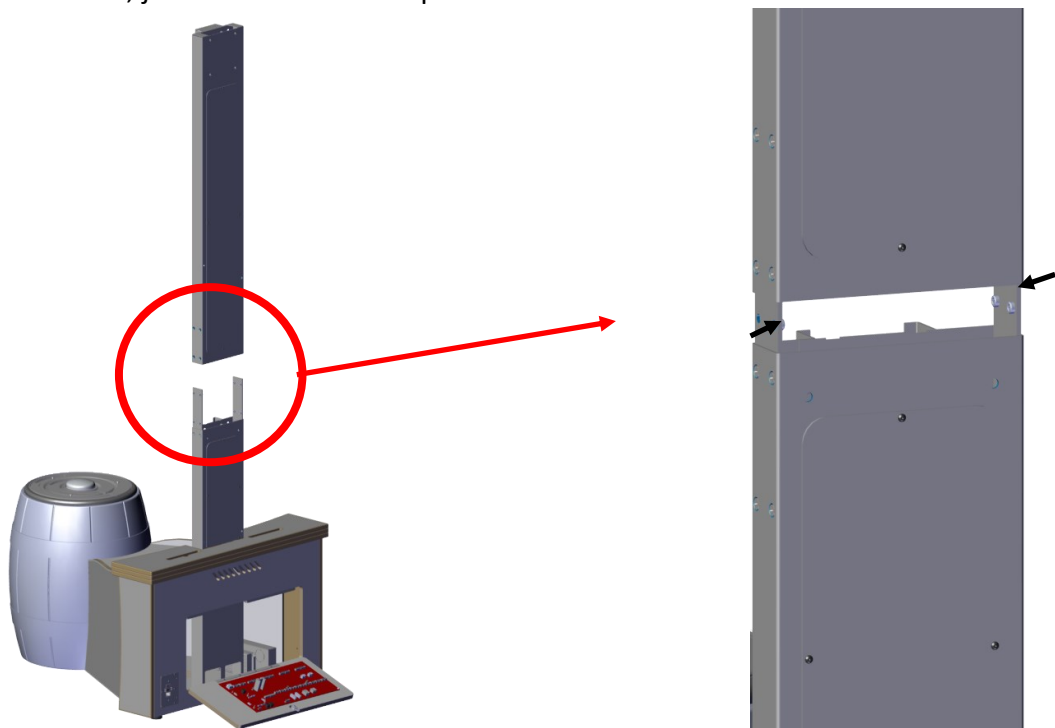

Step 3:

Cut the wire tie shown and all the other below. This will allow you to take one connector harness at a time and insert it through to the bottom where the main board is located. Be careful not to snag and disconnect any other of the other wire harnesses while doing so.

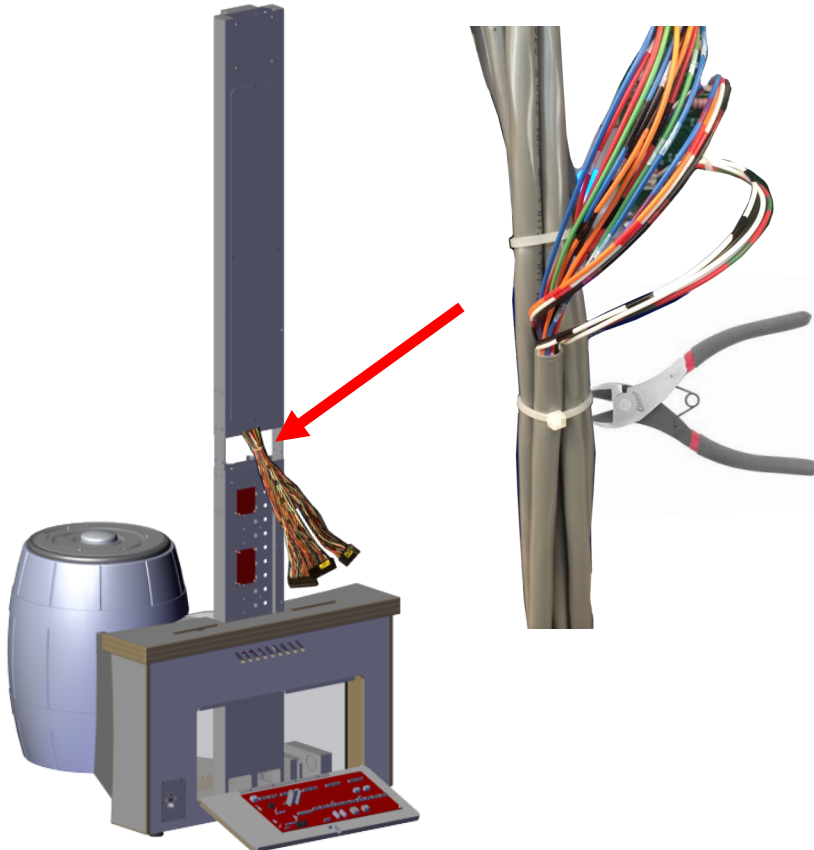

Step 4:

Connect the five harnesses shown below that connects the middle section to the base section. They are color coded.

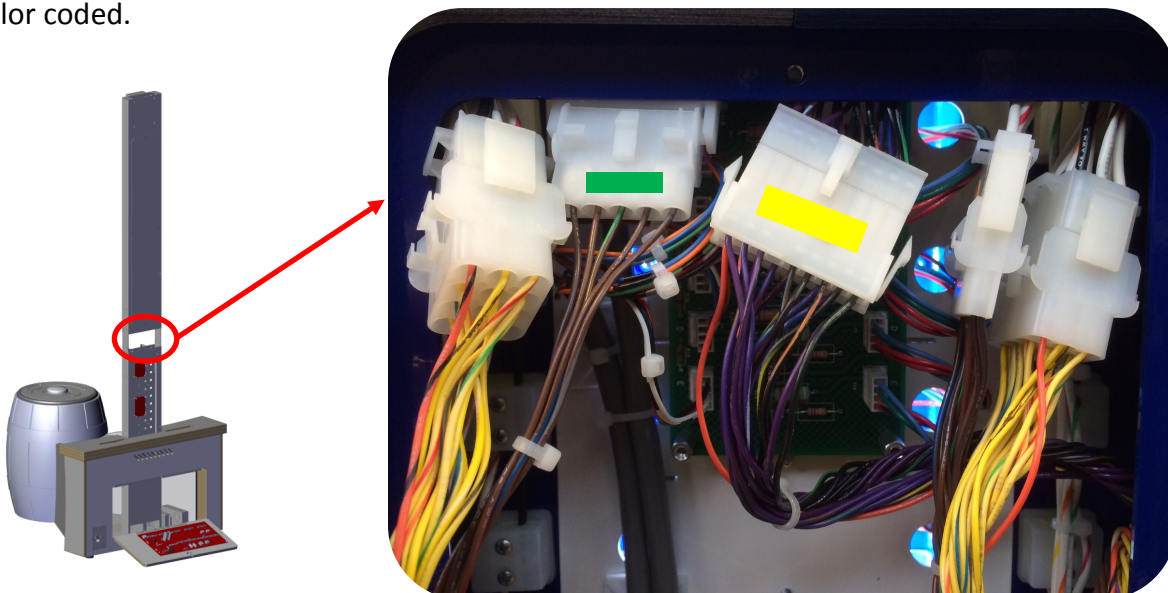

Step 5:

While holding the upper light housing remove the two 1/4-20 x 1-1/4 screws using a # 3 Phillips screw driver on each side and slide the light housing down being careful not to pinch any of the wire harnesses. Attach the light housing using four flat screws on each side (only one side is shown in the diagram).

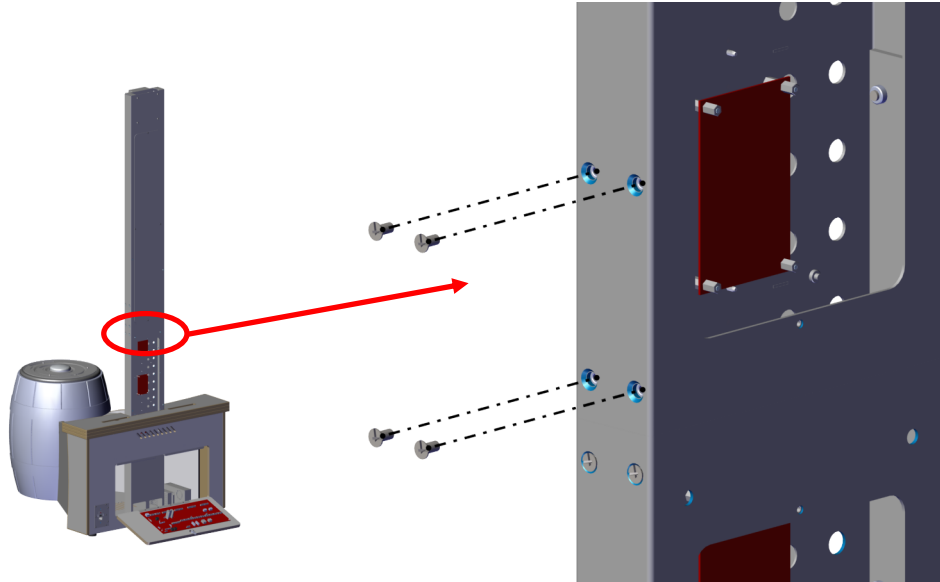

Step 6:

Before lifting the bonus marquee up to the top, open the access door using a 45 key. Put the door aside. Slide the marquee assembly onto the top of the light housing and connect the harness shown below.

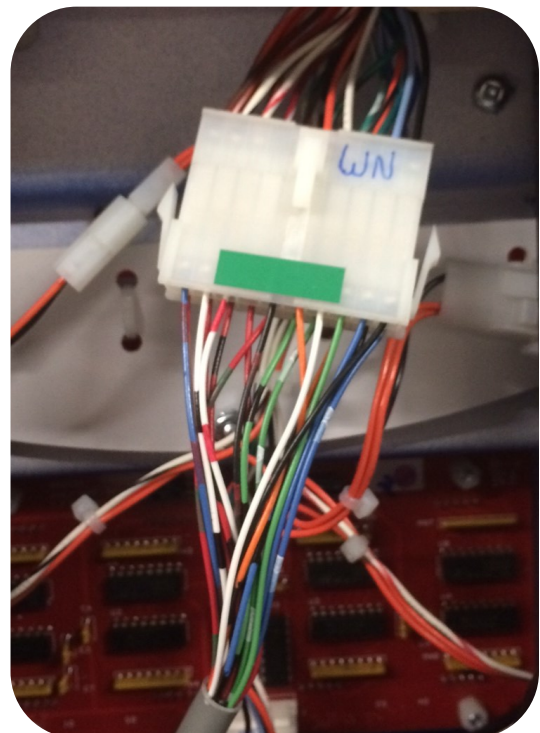
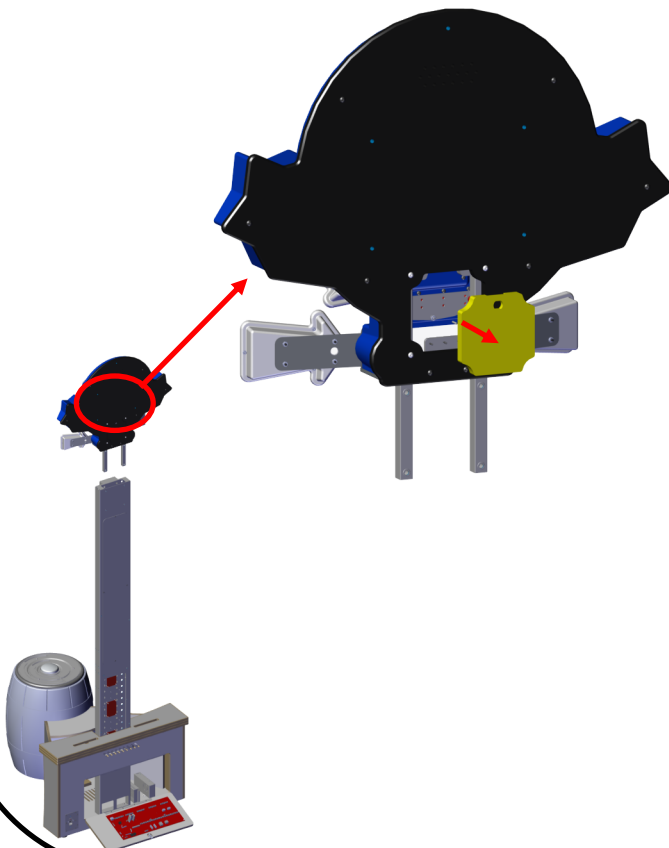

Step 7:

Attach the Bonus Marquee using four Allen bolts. Replace the access panel door.

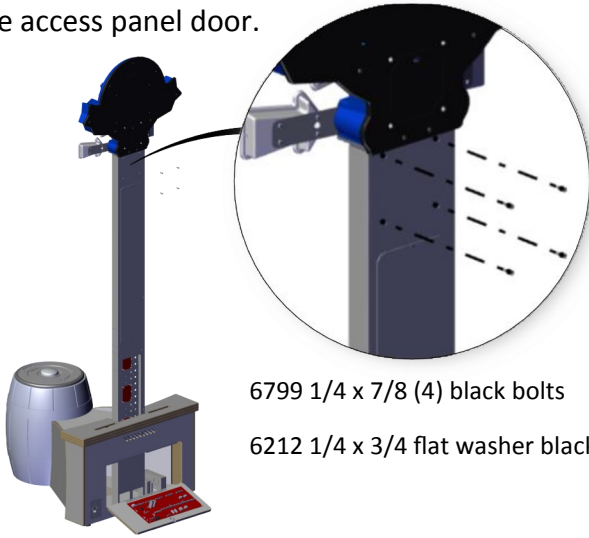

6799 1/4 x 7/8 (4) black bolts
6212 1/4 x 3/4 flat washer black

Step 8:

From the back of the game, attach the right side balloons using three Allen bolts and washers.

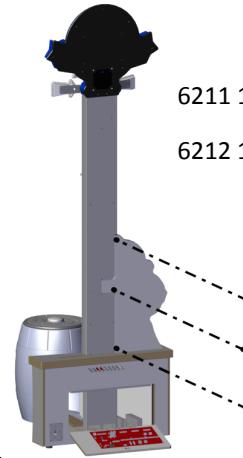

6211 1/4-20 x 1 1/4(3) black bolts
6212 1/4 x 3/4 flat washer black

Step 9:

From the back of the game install the right side balloon. Before lifting onto the cabinet, remove the bottom wire channel to access the harness. Attach with three Allen bolts and washers. Connect the wire harness from the balloon to the base.

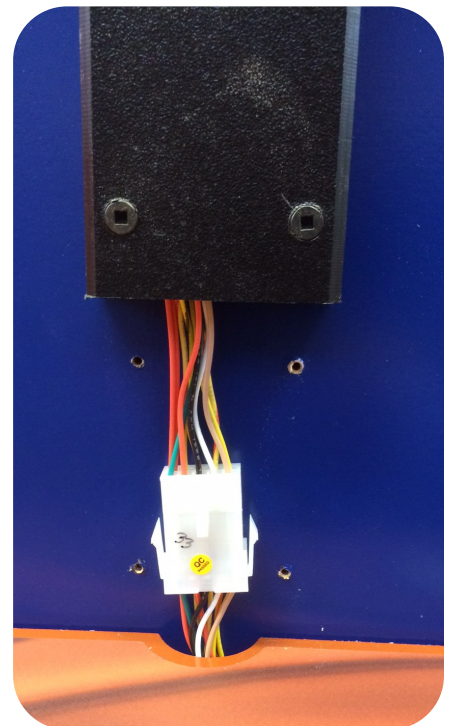
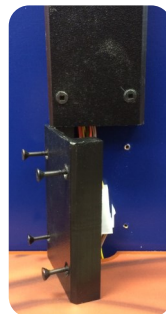
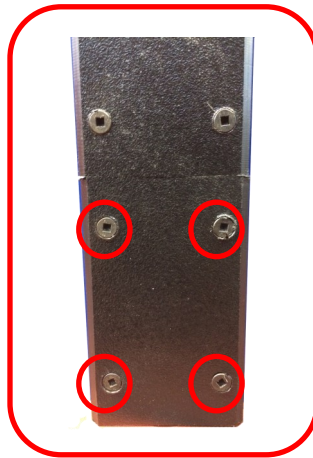
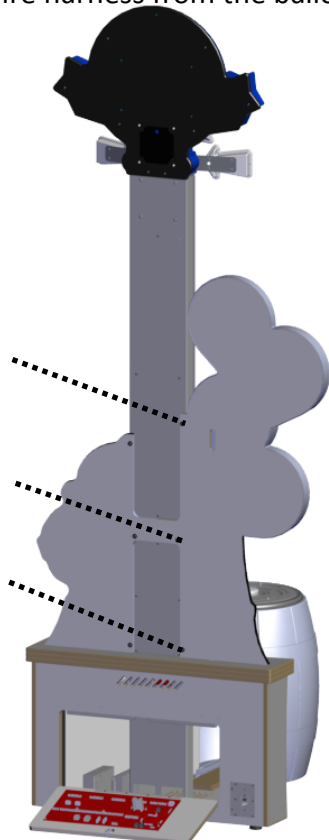

Step 10:

Connect the light housing harnesses to J23, J24, and J25. The harnesses are labeled.

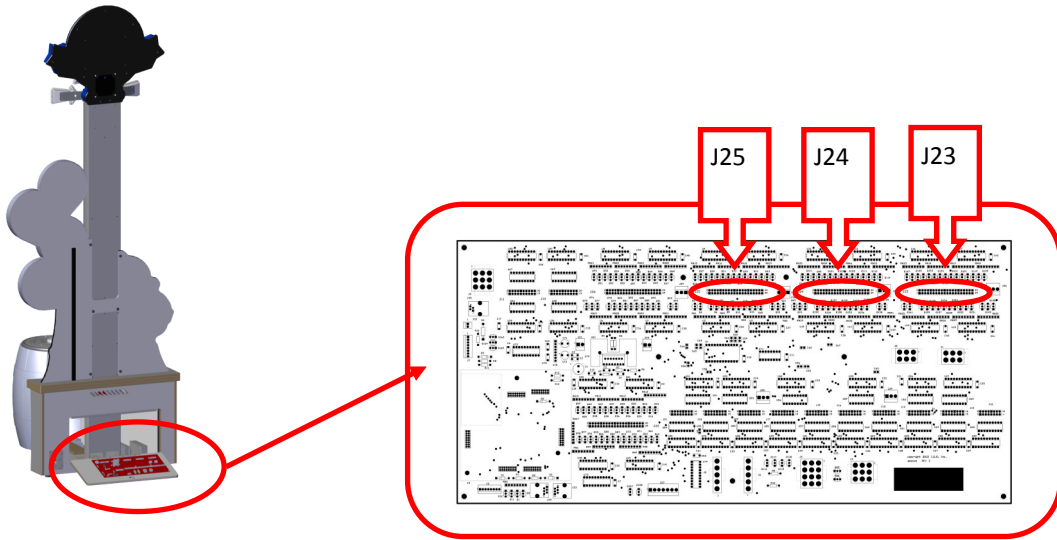

Final:

Align the Playfield score graphic and Clear protective shield together and attach using 18 Phillip screws. You will need to remove the protective film from the plastic before you install.

Start at the top and continue down in pairs. Do not tighten any screws until all of the screws have been installed.

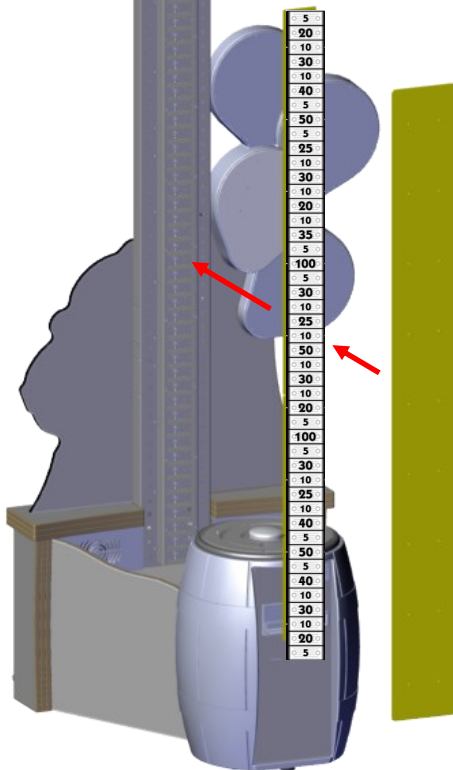

6663 6/32 x 5/8 (18) Silver Phillips

Now that your game is assembled it is time to set the game options. The game's scoring is shown on the Tower Score Chart and it is based on price per play. See the next page for available Tower Score Charts which can be replaced by calling service. You cannot change the values used in the Tower Score Charts. You can change the bonus amount and how much to charge per play.

To determine which Tower Score Chart the game is using, when the power is applied to the game, the balloon to the right will display which Tower Score Chart being used. The display at the top shows the software version. If you want to change the cost of the game, then contact ICE Service Department to order a new Score Chart Tower.

Open the cabinet's lower drawer and at the back you will find the user control panel. Pressing the "PROG" button will enter the programming mode. The lower right balloon shows which option you are adjusting while the upper display shows the value for that option. Pressing the "SELECT" button will advance to the next option. The "UP" and "DOWN" buttons will change the option's value.

Programming Options for Whack N Win Revision 1.06

Option		Min	Max	Inc
0	Game Volume	0	7	1

This option adjusts the general sounds and voices in the game.

1	Music Volume	0	7	1
---	--------------	---	---	---

This option adjusts the music only.

2	Coin 1 line	0	10	1
---	-------------	---	----	---

How many "coin clicks" or pulses from coin 1 coin line to start a game. This line would be the switch with the white/brown wire attached to it.

3	Coin Multiplier	0	10	1
---	-----------------	---	----	---

How many pulses each coin is worth on coin line 2. This line would be the switch with the white/red wire attached to it. This option should be set to 1 unless you are using different coins that have different values. For example if the coin you are using in coin 1 is a quarter and coin line 2 is accepting \$1.00 coins, then this would be set to 4, not 1. If coin line 2 is accepting the same coin as coin line 1, then this would be set to 1.

4	DBV line	0	10	1
---	----------	---	----	---

How many pulses is each coin worth on coin line 2. This line would be the switch with the white/orange wire attached to it (or DBV). This option depends on how you have configured your DBV for what currency you wish to accept. For example, if your coin 1 line accepts quarters and you have configured your DBV to pulse 4 times per dollar, then you would set this to 1. If your DBV pulses only once per dollar, then you would set this to 4.

5	Discount	0	10	1
---	----------	---	----	---

This option allows you to give additional games, based on the amount of money inserted for credits purchased. So if you wanted to give 3 games per \$1.00 and each game cost was .50¢, then this would be set to 2. You would also have to set option 6 to 1. Now when two games are purchased in a row without hitting the "Hit Pad" then the player will receive three games instead of two.

6	Games Discounted	0	20	1
---	------------------	---	----	---

This option works when a value is set in option 5 other than 0. This option determines how many games to give when using the discount option. See option 5 for further explanation.

7	Attract Time	0	90	1	Attract time
---	--------------	---	----	---	--------------

This option sets the time between attract cycles.

Option		Min	Max	Inc
8	Sensitivity	1	15	1

Do not alter this option unless you review the section titled “How to Calibrate the Hit Pad sensitivity”. Decreasing this value increases the sensitivity of the hit pad. Increasing this value will decrease the sensitivity of the hit pad.

PAYOUT OPTIONS:

9	Bonus Window	1	6	1
---	--------------	---	---	---

Picture a garage door open and how easy it would be to throw a ball into the garage. As you decrease this value the garage door begins to close making it harder to throw a ball into the garage. The lower the value, the more closed the door.

10	Bonus Tickets	25	5000	25
----	---------------	----	------	----

This value tells the game how many tickets to pay when a bonus is achieved.

11	Scoring Table	1	9	1
----	---------------	---	---	---

Tells the game which tower score chart to use. See “WN Score Chart “ for options. Your game has the Score Tower Chart that is based on your cost of play.

12	Ticket Divider	0	2	1
----	----------------	---	---	---

This option allows you to disable tickets or use two cent tickets. A setting of 0 disables tickets. A setting of 1 pays out all ticket owed. A setting of 2 pays out half the tickets owed. Any odd value of tickets owed will be truncated. So if 33 tickets are won and you have a setting of 2 only 16 tickets would be paid (it would subtract 1 ticket from 33 to 32 then it would be divided by ½ giving you 16 tickets).

PROGRESSIVE OPTIONS:

13	Games lost to Increment	0	10	1
----	-------------------------	---	----	---

This option tells the game when to increment the bonus when no bonus is won at the end of the game. So if you wanted to increase the bonus every other game, setting this to 2 would increase the bonus every two games lost. The next option sets how much to increase the bonus by. Setting of 0 turns off this feature.

14	Increment bonus amount	0	100	1	When 13 is on, adds these many tickets to the bonus.
----	------------------------	---	-----	---	--

This option tells the game how much to add in tickets to the bonus when using option 13.

15	Bonus Cap	0	2500	25
----	-----------	---	------	----

This option limits the bonus from exceeding this value.

16	Factory Reset	0	1	1	Factory Reset
----	---------------	---	---	---	---------------

**** Note for Option 11 ** Refer to the next page for option number. This must match your score table!**

**** Note for Option 13 ** When the bonus has been won, the bonus will reset back to the value stored in option 10.**

NOTE: If a marquee is attached then the stand alone progressive is disabled and the MQ will take its place. If the game becomes disconnected after that point a reboot will be required to re-implement the stand alone progressive.

The next page shows the Tower Score Charts and shows both their coin values and recommended bonus values.

Score Table Options

8-18-14

Part #	WN7040P	WN7014P	WN7049P	WN7047P	WN7045P	WN7042P	WN7048P	WN7043P	WN7041P
Coin Value	25¢	50¢	50¢/2 point	3 for \$1	75 cents	\$1	\$1/ 2 cent Ticket	\$1.50	\$2
Default Bonus Value	100	500	500	750	750	1000	1000	1000	1000
Program Option #	Option #0	Option #1	Option #9	Option #8	Option #6	Option #2	Option #7	Option #3	Option #4
Score Chart	1	5	4	4	5	5	10	10	10
	4	15	14	12	20	25	20	30	40
	2	5	4	4	5	10	10	10	10
	3	10	10	10	8	15	20	20	45
	2	5	4	4	10	10	10	10	10
	5	20	20	20	15	25	40	40	60
	2	5	4	4	5	5	10	5	10
	4	25	24	20	20	30	50	50	50
	2	5	4	4	5	5	10	5	10
	3	15	14	12	12	20	25	20	35
	2	5	4	4	10	10	10	10	10
	4	25	24	20	20	30	35	30	45
	2	5	4	4	5	10	10	10	10
	5	20	20	20	15	30	40	40	25
	2	5	4	4	10	10	10	10	10
	3	10	10	10	8	15	15	20	50
	2	5	4	4	5	5	10	5	10
	10	50	50	40	40	75	100	100	150
	2	5	4	4	5	5	10	5	10
	3	25	24	20	20	25	30	30	40
	2	5	4	4	10	10	10	10	10
	5	15	14	12	12	20	25	20	30
	2	5	4	4	10	10	10	5	10
	4	30	30	20	20	40	50	50	50
	2	5	4	4	10	10	10	5	10
5	20	20	16	16	30	40	40	25	
2	5	4	4	10	10	10	10	10	
3	10	10	8	8	15	20	20	30	

How to Check if your game is in Calibration.

Step 1: Coin up the game.

Step 2: Using the Mallet to strike the “Hit Pad” as hard as you can! (See Illustration).

Step 3: *If the lights travel to the top of the tower, rebound back down and land in the “Sensitivity Target Zone” then your game is Calibrated. (see Illustration)*

Step 4 : If the lights do not land in the “Sensitivity Target Zone” then you will need to adjust OPTION 8 in programming. See A-E below:

- A) Open the cabinets front drawer and inside you will find the User Control Panel.
- B) Press the “PROG” button once and the “Right Balloon” will Display the option you are adjusting. **IF you accidentally hit a wrong button and the game is not responding normally... then turn off/on the game. (cycle power and start over)**
- C) Press the “SELECT” button until the “Balloon Display” reads 08. (You will need to press “SELECT” 8 times)
- D) Press the “UP” or “Down” button to change the “SENSITIVITY VALUE” (The Marquee BONUS DISPLAY on top of the tower will indicate the new “SENSITIVITY VALUE”. The “Balloon Display” should remain at 08)

Decrease the Value of Option 8 if the lights do not rebound off of the top of the tower. (Degrease Marquee Value Display by pressing “Down” button)

Increase the Value of Option 8 if the lights rebound off of the top of the tower and travel past the “Sensitivity Target Zone” (Increase Marquee Value Display by pressing “UP” button)

- E) Once you have **Increased or Decreased** the Marquee value in option 8 you must press the “PROG” button to exit.
- F) Repeat Steps 1—4 until your game is Calibrated.

**** Note **** The “Sensitivity Target Zone” is between the two highest numbers on the Tower’s Score Chart. Your Tower’s Score Chart might differ from the picture shown.

STEP 2: Whack the “Hit Pad” as hard as you can with the Mallet! (Do this after you “coin up” the game.)

IMPORTANT: RECORD ALL SETTINGS ON THE CERTIFICATE LOCATED ON THE SIDE OF THE FRONT DRAWER - OR— USE THE REVERSE SIDE OF THIS PAPER IF IT CONTAINS A CALIBRATION CERTIFICATE.

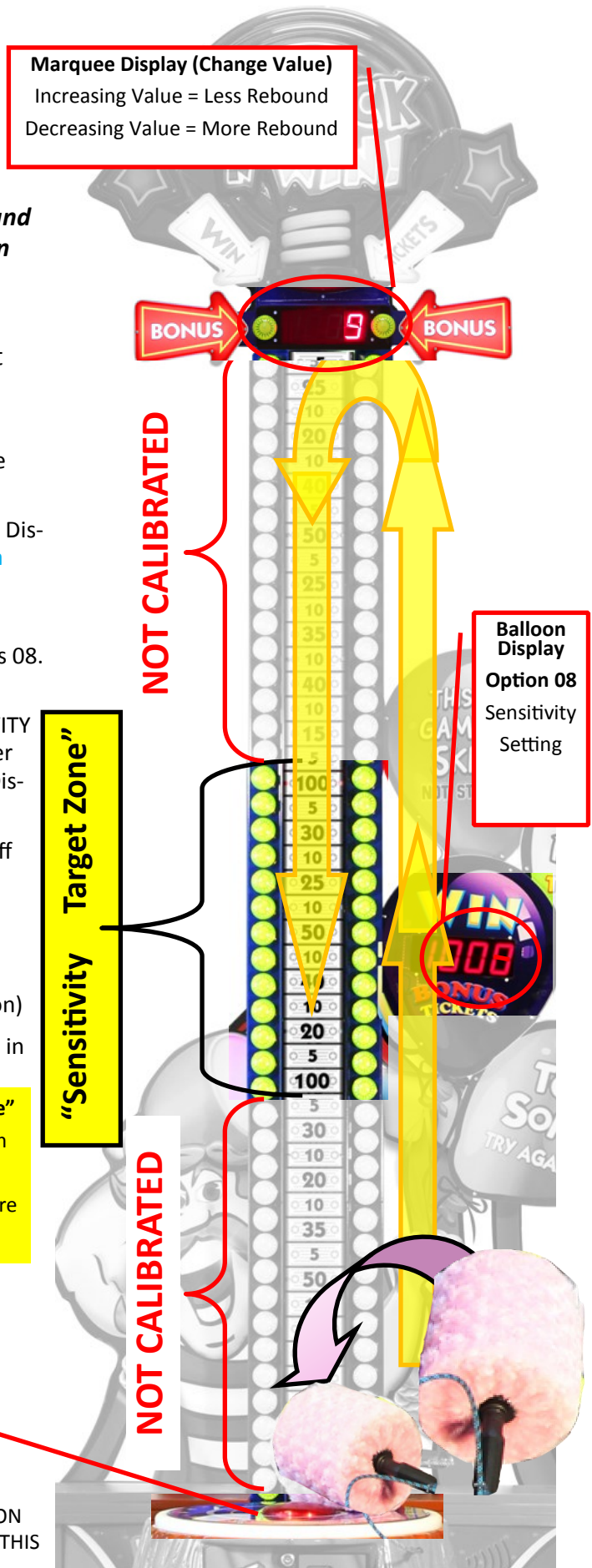

Accessing Upper LED light strips and Display Board

To gain access to the electronics found inside the upper marquee, you will need to remove the upper marquee. Remove the four 1/4-20 x 7/8 bolts and washers holding the marquee in place (1). Open the back access door and unplug the harness (2 + 3). Lift the marquee up and place the marquee face down onto a table (4).

Remove the Square bit screws around the outside of the marquee (5). Using a wrench on the inside, remove the two lower 1/4-20 Allen bolts (6). Now separate the back assembly from the front (7).

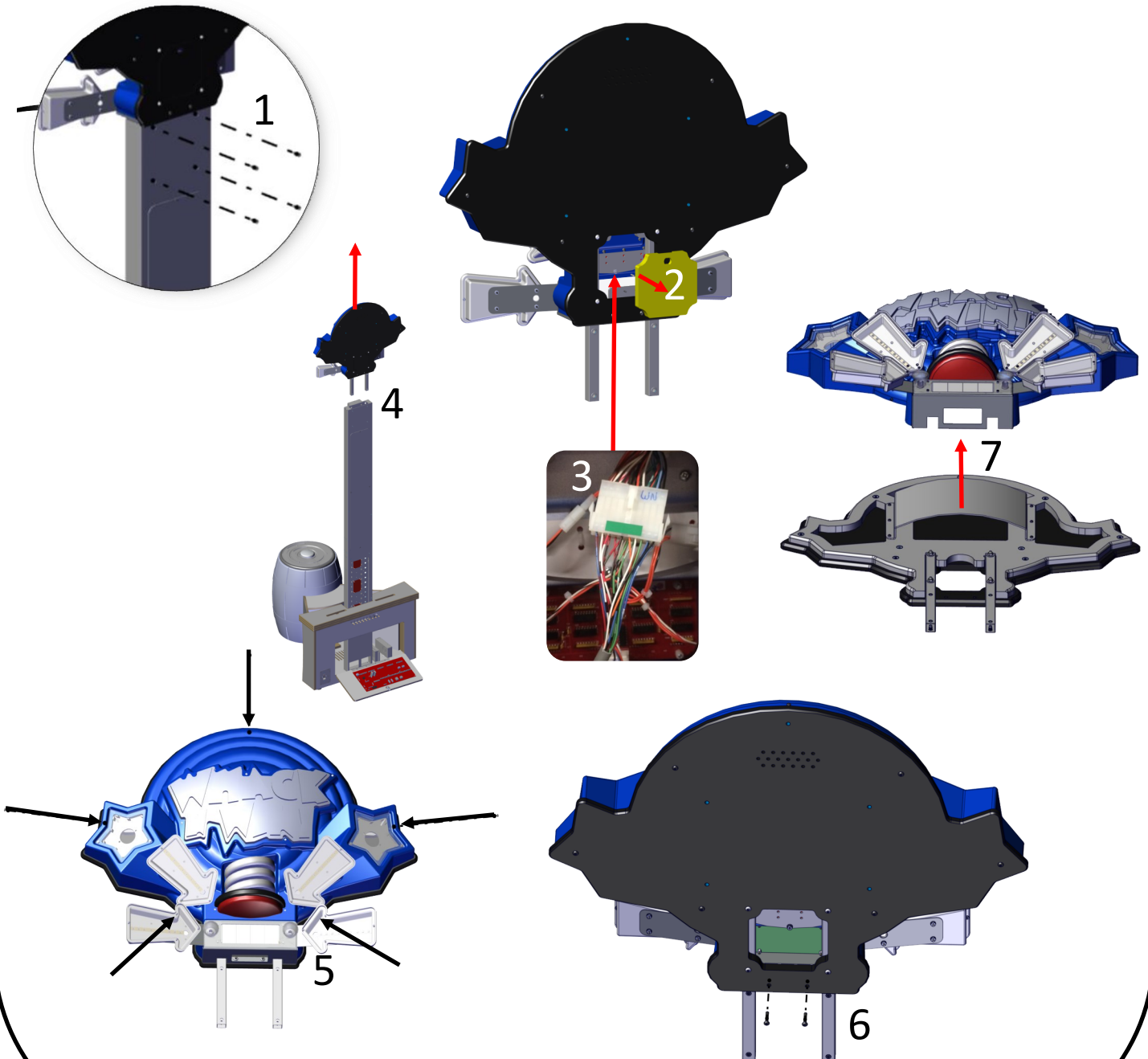

Changing the Tower Score Card's Values

To change the Tower Score Card, remove the plastic shield and old Tower Score Card. Starting from the top, reinstall the silver Phillips screws. Power the game on and press the program button. Cycle through the options until option 11 is displayed. Enter the value for your tower score card. Refer to page 11 for score table value which is shown between () for option 11 of the game.

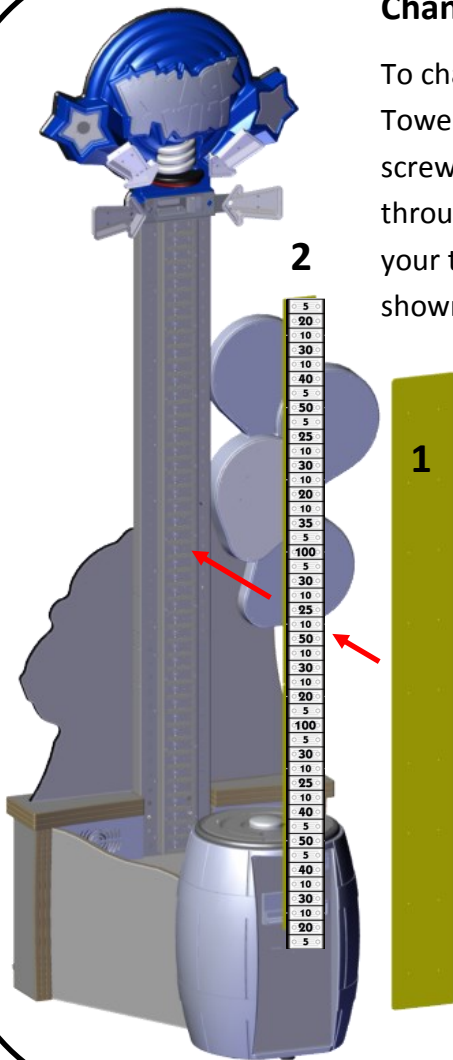

GAME POWER SUPPLIES

There are two power supplies located at the back of the game. The IA2010 power supply provides the +12 DC volts to the game board, lights, and outer Fun lights. The WN2010 power supply provides the +5 DC voltage for the game logic and center LEDs.

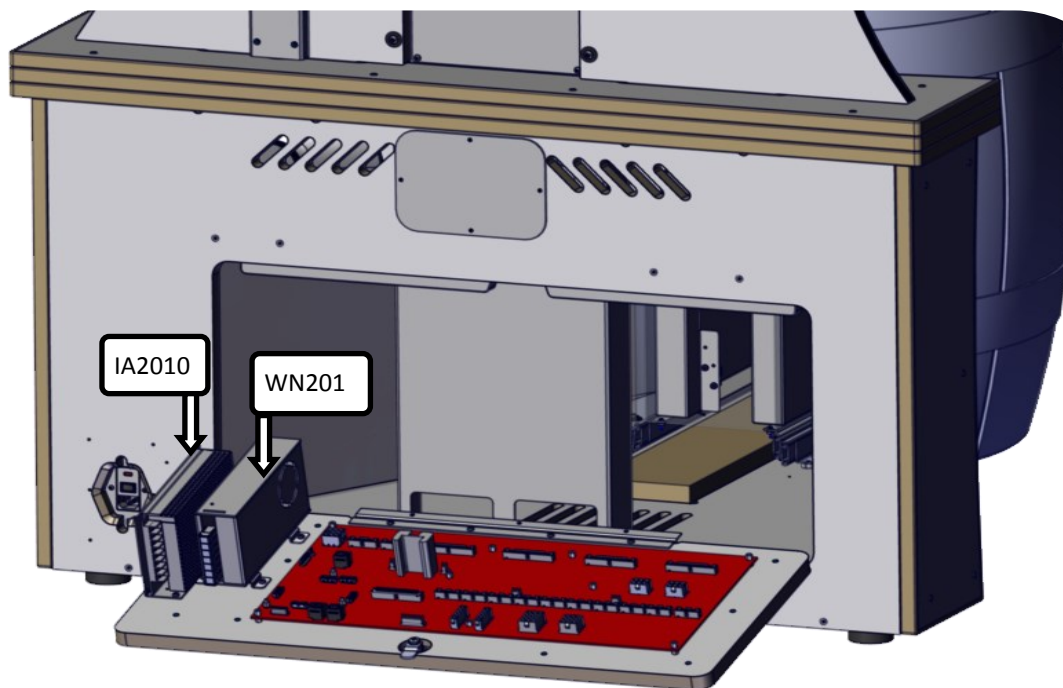

WN1052X Piezo Sensor Assembly Replacement

Open the bottom drawer and from underneath the barrel's top remove the three bolts labeled as A,B, and C (1). Unplug the harness and lift the assembly out. When replacing, use the upper hole to feed the wire harness through.

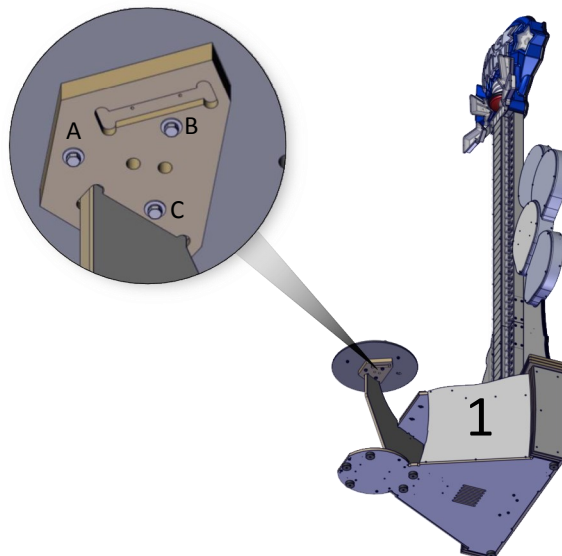
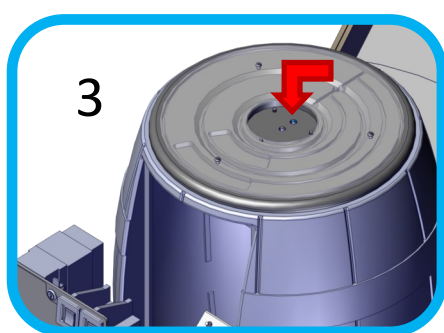

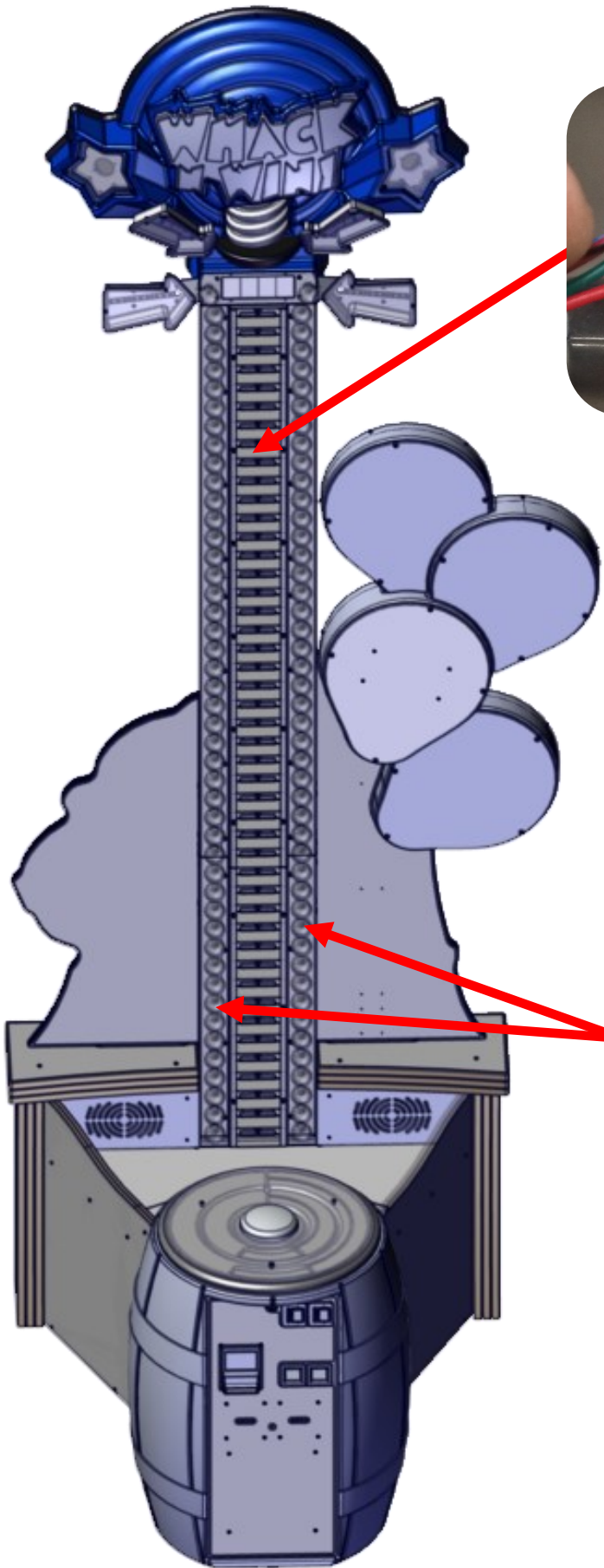

E00869W NX

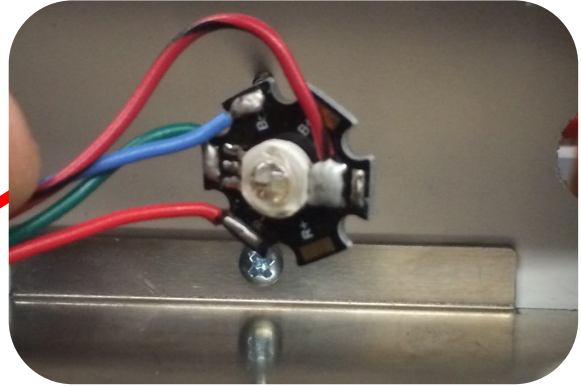

+5 volt LED Lights are mounted with the red w/brown wire loop at the top, over the mounting screw. **HAND TIGHT PLASTIC NUTS!**

DO NOT USE POWER TOOLS TO INSTALL!!



+12 volt LED Fun Lights. To access the bulb, unscrew the plastic cover.

Spare Parts List

Harnesses:

WN2051HX	HARNESS (MAIN)
WN2052HX	HARNESS (COIN DOOR)
WN2060LX	HARNESS (DC POWER)
WN2063LX	HARNESS (5V DC POWER)
WN2064LX	HARNESS (POWER SUPPLY AC)
WN2080LX	HARNESS (RGB EXTENSION 1-5)
WN2081LX	HARNESS (RGB EXTENSION 6-15)
WN2082HX	HARNESS (RGB EXTENSION CABLES)
WN2085HX	HARNESS (FUN LIGHTS EXTENSION A)
WN2086MX	HARNESS (FUN LIGHTS EXTENSION B)
WN2087HX	HARNESS (FUN LIGHTS)
WN2097ELX	HARNESS (MARQUEE EXTENSION)
WN2097ILX	HARNESS (MARQUEE INTERFACE)
WN2098LX	HARNESS (BALLOON LEDS/BONUS DISP)
VW2053HX	HARNESS (TICKET DRAWER)

Decals:

WN7000	DECAL (FRONT DOOR) COUPONS
WN7002	DECAL (SIDE LEFT)
WN7003	DECAL (SIDE RIGHT)
WN7005	DECAL (REAR CABINET SIDE)
WN7007	CONTROL PANEL (MAT/PRINT)
WN7008	DECAL (REAR CABINET TOP LEFT)
WN7009	DECAL (REAR CABINET TOP RIGHT)
WN7010	DECAL (CARNIE BACKGROUND LEFT)
WN7011	DECAL (CARNIE BACKGROUND RIGHT)
WN7029	BALLOON GREEN (MAT/PRINT)
WN7013	SPEAKER COVER (MAT/PRINT)
WN7014	PLAYFIELD (MAT/PRINT) \$.50
WN7025	BALLOON RED (MAT/PRINT)
WN7026	BALLOON BLUE (MAT/PRINT)
WN7027	BALLOON PURPLE TICKET (MAT/PRINT)

Electronics:

E00418WNAX	ASY (WHITE 27 LED TAPE STRIP)
E00724WNAX	ASY (RGB 81 LED TAPE STRIP)
E00724WNBX	ASY (RGB 54 LED TAPE STRIP)
E00724WNBX	ASY (RGB 27 LED TAPE STRIP)
E00788WNBX	ASY (WHITE LRG 60 LED STRIP)
E00843	"LED, E10, CLUSTER OF 12 (MEDIUM)"
E00869WNBX	"ASY (5V RGB LED, PCB CONN)"
E2034XX	PCBA (BRAIN BOARD W/ 8716 FLAS
IA2010	POWER SUPPLY +12VDC 10A (ROHS)
IA4004	ROPE 6mm Blue
PW2007PG	GREEN NEON MINI FUNLIGHT BULB
TA2032X	PCBA (DISPLAY)
TX2007X	ASY (POWER MODULE 5 AMP)
WN2010	"POWER SUPPLY (5VDC, 40A)"
WN2034X	PCBA (I/O)
WN2035X	PCBA (RESISTOR)
WN3002	CONTROL LED PANEL
WN7028X	ASY MARQUEE

MISC:

WN4010	MALLET
MA3006	T MOLDING (25/32 YELLOW) 105-2
PE1350	DRAWER SLIDE 18



WARRANTY POLICY

I.C.E. Inc warrants all components in new machines to be free of defects in materials and workmanship for the period listed below:

- 180 days on Main PCB's, Computers & Motors
- 1 year on all LCD monitor panels
- 90 days on all other electronic and mechanical components
- 30 days on all I.C.E. repairs and parts purchases

I.C.E. Inc shall not be obligated to furnish a warranty request under the following conditions:

- Equipment or parts have failed through normal wear and tear
- Equipment has been subjected to unwarranted stress, abuse or neglect
- Equipment has been damaged as a result of arbitrary repair/modification

Products will only be covered under warranty by obtaining an I.C.E. authorized RMA #. To obtain an RMA # please provide I.C.E. tech support with the game serial # or original I.C.E. invoice # and a detailed description of the failure or fault symptoms.

I.C.E. Inc will assume no liability whatsoever for costs associated with labor or travel time to replace defective parts. All defective warranty covered components will be replaced with new or factory refurbished components equal to OEM specifications.

I.C.E. Inc will cover domestic UPS ground, or comparable shipping costs during the warranty period. International or expedited shipments are available for an additional charge. To obtain credit defective parts must be returned to I.C.E. Inc, at the customer's expense, within 30 days. After 30 days a 15% re-stocking fee will apply to all returns.

ICE distributors are independent, privately owned and operated. In their judgment, they may sell parts and/or accessories other than those manufactured by I.C.E. Inc. We cannot be responsible for the quality, suitability or safety of any non-I.C.E. part or modification (including labor) that is performed by such a distributor.

Innovative Concepts in Entertainment

10123 Main St.

Clarence, NY 14031

Phone #: (716) - 759 – 0360

Fax #: (716) – 759 – 0884

www.icegame.com