



Salsa



USA Edition
(Coin-In, Ticket Out, Non-Feature)

Produced by :
Harry Levy Amusement Contractor Ltd
Distributed in North and South America exclusively by:

COASTAL AMUSEMENTS, INC.
1935 Swarthmore Ave.
Lakewood, NJ 08701 (USA)
Tel: 1-732-905-6662 Fax: 1-732-905-6815
e-mail: sales@coastalamusements.com
Visit our web site at: www.coastalamusements.com

Contents

Section 1 **Commissioning**

- 1.1 - Receipt of machine
- 1.2 - Electrical connection
- 1.3 - Electrical supply entry
- 1.4 - Physical dimension
- 1.5 - Initial operation

Section 2 **Access**

- 2.1 Access to the machine

Section 3 **Game Operation**

- 3.1 - The game
- 3.2 - Priming the playfield with coins
- 3.3 - General care and maintenance

Section 4 **Electrical Systems**

- 4.1 - Circuit breakers
- 4.2 - Ticket board
- 4.3 - Sound board
- 4.4 - Hoppers
- 4.5 - Hopper microphone board
- 4.6 - Tilt board
- 4.7 - Power supplies
- 4.8 - Alarm board
- 4.9 - Coin-in sensors
- 4.10 - Counters
- 4.11 - Swipe change facility (Optional Fit)

Section 5 **Lighting**

- 5.1 - Fluorescent lighting
- 5.2 - Dichroic lighting

Section 6 **Mechanical Systems**

- 6.1 - Pusher motor drive
- 6.2 - Coin entries
- 6.3 - Pusher boxes

Section 7 **Fault Finding**

- 7.1 - Methodology
- 7.2 - System checking
- 7.3 - Basic checks

Section 8 **Spares Listing**

1.1 **Receipt Of Machine**

Upon receipt of machine carefully remove all protective packaging and establish machine on a flat and level floor. Take care to protect the machine from sudden shocks etc. when lifting or manhandling.

The machine should only be situated indoors, and should not be subjected to any other environments. Ensure all ventilation grills have at least 4" (100mm) clearance from other surfaces to permit adequate cooling.

1.2 **Electrical Connection**

The Salsa machine should be connected to the mains supply via a suitable plug to suit your installation requirements (Ref: Section 2.1). A competent trained person should always carry this out. If in any doubt, consult a qualified electrician.

Mains wiring:	Live	Black
	Neutral	White
	Earth	Green/Yellow

THIS MACHINE MUST BE EARTHED/GROUNDED

1.3 **Electrical Supply Entry**

This machine may have the electrical supply connected either at the base or at the very top, as best suits the location in which the machine is situated. The base feed entry socket is located in the base skirt of the machine below section 1 cash box door. The top feed entry socket is located on the top surface of the top sign.

The On/Off switch for the machine is located in section 1 lower compartment. The switch is a three-position switch, with the central position being 'Off'. Left and right of this position are 'On - Top Feed' and 'On - Bottom Feed' respectfully.

1.4 **Physical Dimension**

See following page....

Rhythm & Blues

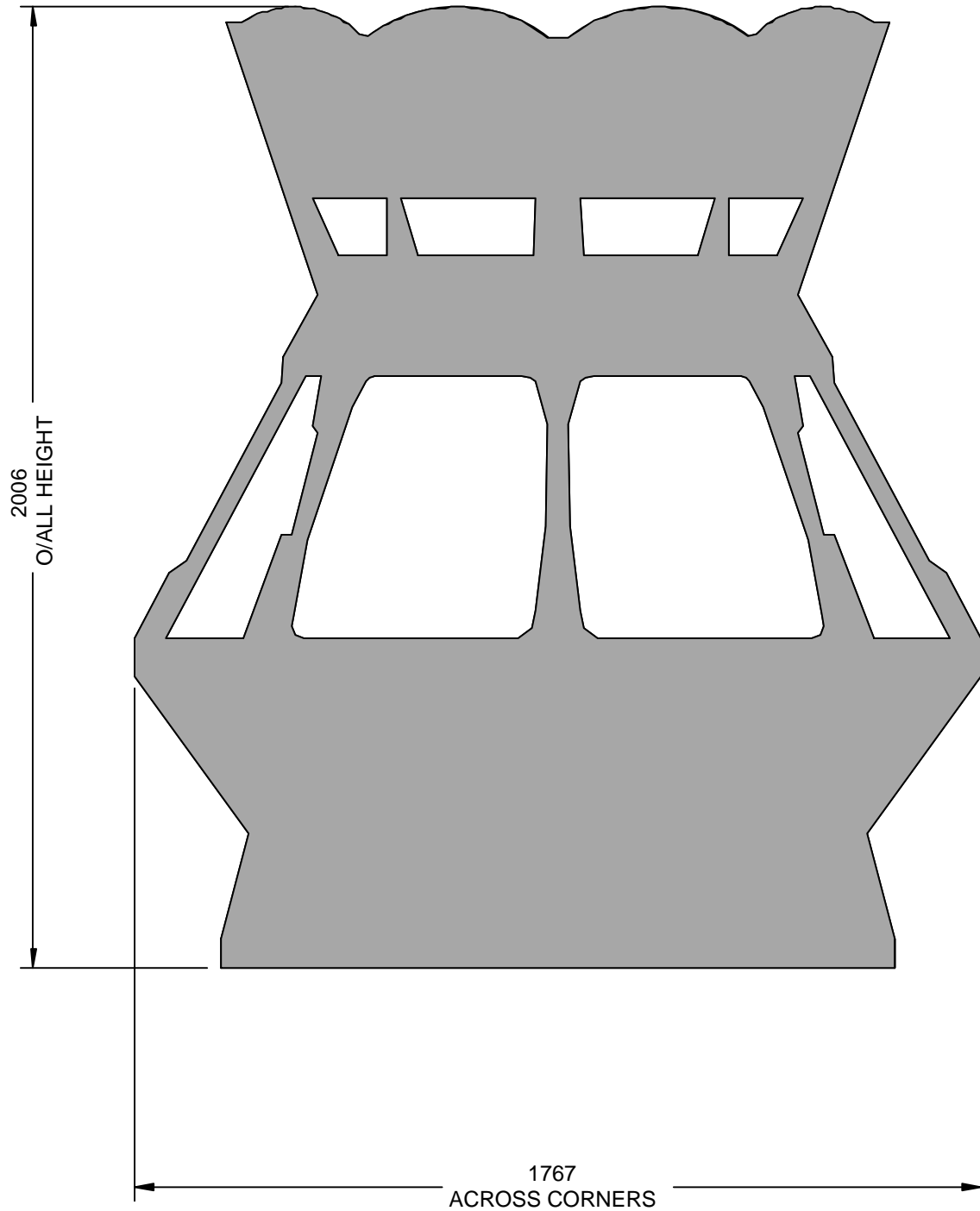

1.5 **Initial Operation**

Connect the mains supply and switch ON (Ref: Section 1.3).

The Top-Sign fluorescent lamps will illuminate and the pusher boxes start moving.

A short time later the 'Attract' sound will operate depending on the switch settings on the Sound Board. The volume level may be adjusted if required by means of a volume control fitted on the Sound Board.

Insert a coin in to the coin entry chute; a tune will be heard as the coin is accepted. The corresponding section coin-in counter will increment and the player section will become active. The game is now initiated and will remain so for approximately 20 seconds.

The anti abuse 'slam-tilt' alarm feature may be tested by thumping on a lower cabinet door. The alarm should sound, and the playfield lights go out. The count hopper will run, diverting any coins falling off the playfield into the cashbox. The count output from this hopper is ignored during tilt conditions, thus no awards made. The operation of the tilt or slam tilt alarm stops all games in progress and lasts 10 seconds.

A safety feature is incorporated which will stop the pusher drive motor should a jam or restriction occur. Simply holding back an advancing pusher box may test this. To effect reset of this feature, operate the reset switch located beneath the lower cabinet door of section one.

2.1 **Access To Machine**

WARNING - DANGEROUS VOLTAGES EXIST WITHIN THIS MACHINE

Playfield

Release the lock at the top of the glass and hinge backward far enough to get a firm handhold either side. Carefully lift clear of the machine and store safely.

Coin-Entry

Release the lock at the top of the door and hinge backwards. Lift clear.

Lower Cabinet

Each player section has an access door below the playfield which may be fully removed by releasing the locks, hinge outward, disconnect cables at connectors and lift clear.

Cashbox

Each player section has an access door located below the lower cabinet, which can be fully removed by releasing the lock at the top, hinge outward, and lift clear. The cash box is located within.

Top-Sign

The artwork panels may be unscrewed and removed, permitting access to the top sign.

3.1 **The Game**

Attract Mode

When not in active play, the machine lighting and pusher box mechanism operate continuously. The attract tune is played at intervals dependant on the settings made on the Sound Board

Active Play Mode

When coins of the correct type are inserted into a coin entry chute they are detected by an optical sensor activating that particular player section and then pass down the pin perspex to the playfield. Coins of the incorrect type fall through the chute and are collected in the reject trays, not activating the sensors.

When the player section is active, coins over the edge are detected by a microphone connected to the win chute, which in turn activates the count hopper. The coins are counted in to the cash box, and the count processed to generate the award of redemption tickets. After coin entry, a player section remains enabled for approximately 20 seconds, allowing the player the full benefits from the effects of his coin.

Coins in and tickets out are recorded on separate electro-mechanical counters. It is recommended that readings of these counters be taken regularly, to establish a clear pattern of usage/profit and thus any significant deviations may highlight a fault condition requiring attention.

3.2 **Priming The Playfields With Coins.**

Each player section requires approximately 800 coins, of which the first 750 may be hand placed on the playfield. The final 50 for each section should be played in to the machine via the coin entry slots in order to achieve the best possible visual appearance of the playfield area.

Remember to record the coin counter readings after priming for your records.

3.3 **General Maintenance & Care**

The Salsa is a robust and reliable machine, which looked after will give years of profitable service. Regular cleaning is the key to optimum condition and performance.

To maintain all visible surfaces in an 'as new condition':

3. Plastic and Glass Fibre - use a general purpose (non aggressive) water based detergent and finish with a quality furniture polish.
2. Laminated Cabinet trims - clean with an all purpose non-aggressive cleaner and finish to a high gloss using a furniture polish.
3. Glass and Chrome - clean with a quality window cleaning solution.

Do not use caustic or abrasive cleaners. Always use cleaning products in accordance with the manufacturers instructions.

The Salsa utilises 'sealed for life' type bearings and a high quality mechanical components that do not require regular greasing or regular servicing.

It is recommended an initial inspection be carried out after approximately two months usage, to check for any signs of wear on the moving parts. Adjust as required, and thereafter inspect annually.

4 Electrical Systems

4.1 Circuit Breakers

Mains Supply Circuit Breaker

The Mains Supply is protected by a thermally operated circuit breaker, which can be manually reset. This circuit breaker is located in a metal enclosure together with the main supply switch, located in No1 section lower cabinet.

Should this device trip, firstly ascertain the cause of the fault and rectify. To reset the device, simply depress the yellow centre back in to the body of the circuit breaker.

Motor Fuse

The Motor fuse is located on the motor control PCB. This fuse is designed to protect the motor control circuitry and must only be replaced with an identical item. Failure of this fuse would normally indicate a motor fault.

Motor fuse 2 Amp (T) 20mm
(T) = Time Delay/Anti-Surge

Power Supplies

The machine power supply unit and the dichroic transformer units all have circuit breakers fitted in the low voltage sides of the circuits. These circuit breakers are physically mounted within the metal enclosures of these units, and the reset buttons are easily accessible with out opening the units.

Resetting these devices, having identified and rectified the fault condition, is simply a case of pressing the white button back in to the body of the device. Since these are thermally operated devices, a small ‘cooling down’ time may be required after tripping before reset can be achieved.

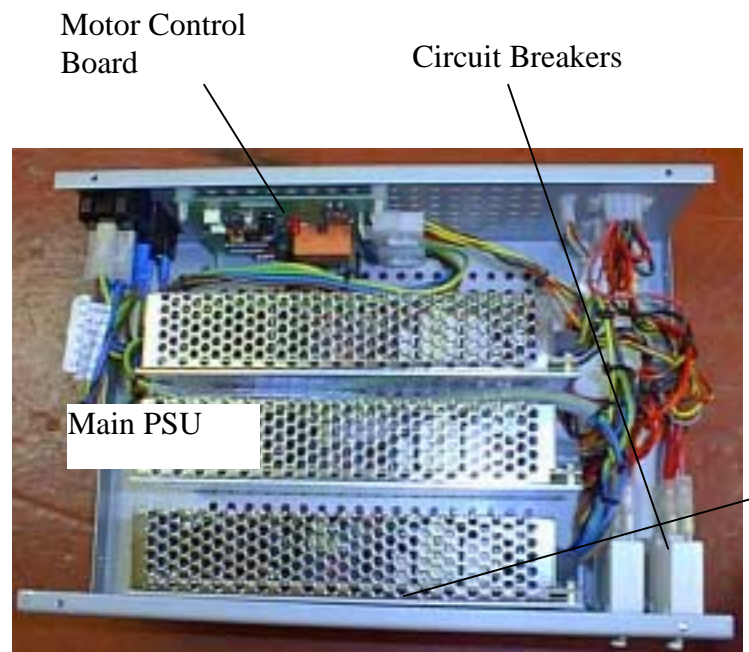

4.2 Ticket Board

The Ticket board is the 'game processor' of each player section. It is located on the left hand side web of each section lower compartment.

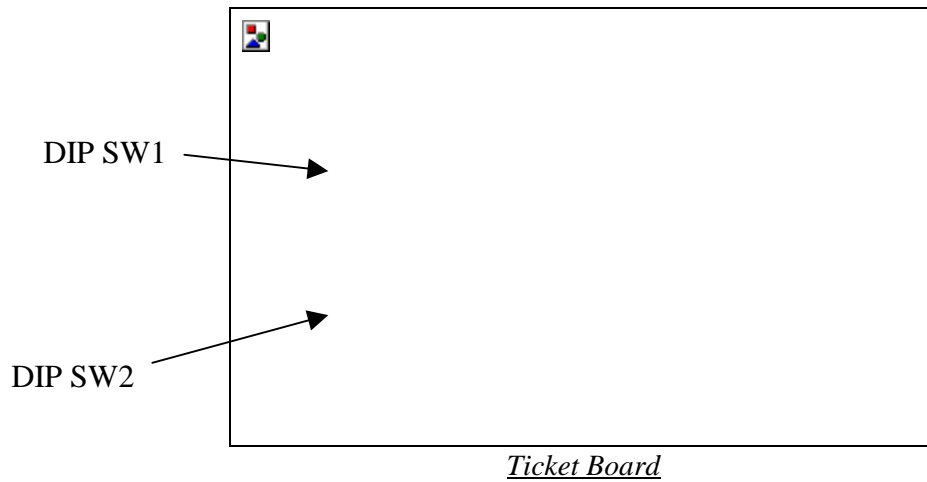

Program: JJUSA24 V1.0

DIP Switch Settings:

DIP Switch 1

Poles 1-3: Consolation awarded on coin entry

<u>1</u>	<u>2</u>	<u>3</u>	<u>Qty Award</u>
off	off	off	0
on	off	off	1
off	on	off	2
on	on	off	3
off	off	on	4
on	off	on	5
off	on	on	6
on	on	on	7

Pole 4: OFF -Token award for coins won
ON -Ticket award for coins won

cont'...

Ticket board switch settings cont'...

DIP Switch 2

Poles 1-4: Payout ratio - No. coins over the edge for award.

<u>1</u>	<u>2</u>	<u>3</u>	<u>4</u>	<u>Qty Coins</u>
off	off	off	off	1
on	off	off	off	2
off	on	off	off	3
on	on	off	off	4
off	off	on	off	5
on	off	on	off	6
off	on	on	off	7
on	on	on	off	8
off	off	off	on	9
on	off	off	on	10
off	on	off	on	11
on	on	off	on	12
off	off	on	on	13
on	off	on	on	14
off	on	on	on	15
on	on	on	on	16

4.3 Sound Board

The sound board is located in section two on the LHS web.

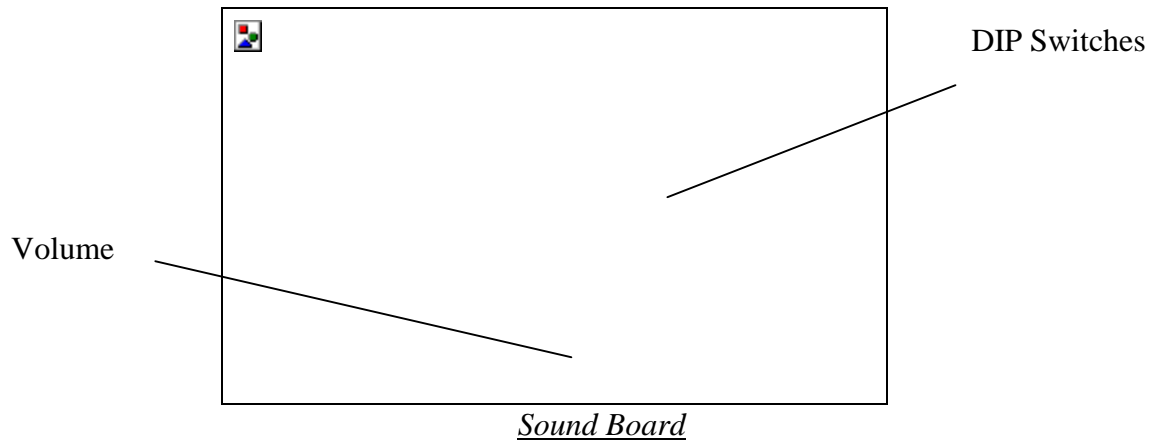

Program: PIC: QSOUND29 V1.3
 EPROMS: RHYTHMA1 V1.2
 RHYTHMA2 V1.2
 RHYTHMA3 V1.2

Continued...

Continued...

DIP-Switch settings

<u>Pole</u>	<u>1</u>	<u>2</u>	<u>3</u>	<u>Select</u>
	off	off	off	No attract music
	on	off	off	30 sec attract music interval
	off	on	off	60 sec attract music interval
	on	on	off	90 sec attract music interval
	off	off	on	120 sec attract music interval
	on	off	on	150 sec attract music interval
	off	on	on	180 sec attract music interval
	on	on	on	210 sec attract music interval

<u>Pole</u>	<u>4</u>	<u>5</u>	<u>6</u>	<u>Coin-In Sound</u>
	off	off	x	One sound (Guitar)
	off	on	x	Two alternate sounds (clarinet & Piano)

x = 'don't care' – on or off

Pole 4 'on' gives a test mode of the attract sounds (virtually continuous). In standard operation this pole should remain 'off'.

Loudspeaker (6979)

The loud speaker is located in the top of the coin entry area. It is rated at 8 Ohms 25 watts.

4.4 **Hoppers**

The hopper fitted in each player section is a 'count' hopper. This hopper is used solely to count the number of coins that fall over the edge of the playfield, directing it's output to the cashbox. This hopper does not need initial priming with coins and should always 'run to empty'. Each section hopper is controlled in its operation by the 'ticket board'.

4.5 Hopper Microphone PCB

Each player section has a Piezo coin detector microphone. The Piezo microphone is part of the win chute assembly. The sound detector PCB is located in the lower cabinet of each section on the left hand side wall.

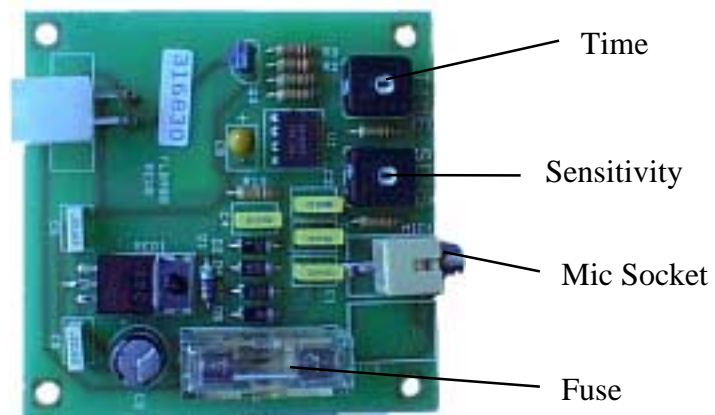

Microphone PCB (Sound Detector)

4.6 Tilt board

The Tilt board is located in the top sign. This board has a pendulum tilt device (located in the top sign) and the slam tilt switches (all lower compartment doors) as its inputs. Should any one of these inputs be activated, the tilt board immediately activates an audible alarm (located in the top sign) and switches off the mains lighting in the top sign, so as to indicate which machine is being tampered with. Provided there are no further inputs, the tilt alarm condition will only remain active for a short period of time, when it will then automatically reset.

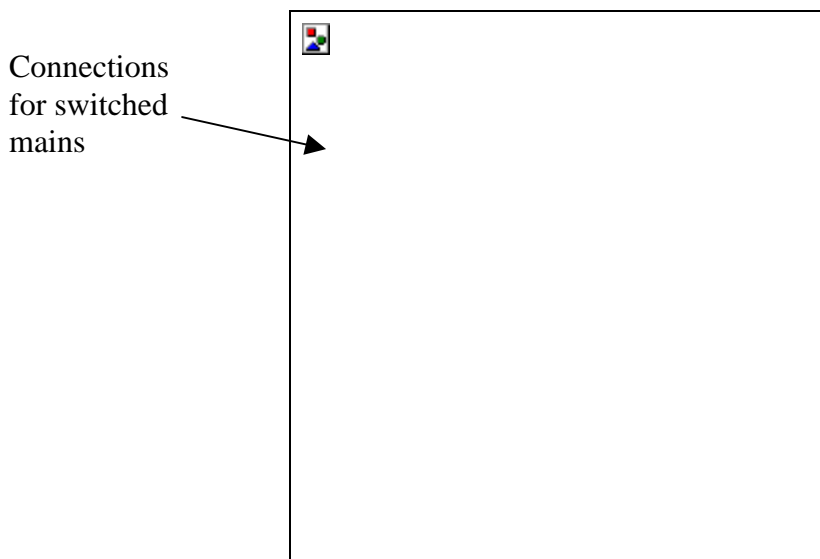

Tilt Board

4.7 **Power Supplies**

WARNING - Dangerous voltages (115 V) - Disconnect from the mains supply!

The main power supply unit contains 12 and 24 volt switch-mode power supply units, the motor control board and DC supply circuit breakers. This unit provides all the DC supplies for use in the machine.

The low voltage AC supplies for the dichroic lighting are provided from a transformer mounted in separate units. The main dichroic unit contains a transformer and a circuit breaker for each dichroic lamp.



Dichroic Lighting PSU



Main PSU

4.8 **Alarm Board** (7819)

Located in the toposign, this board drives a sounder to produce the alarm tone for tilt, motor jam etc.

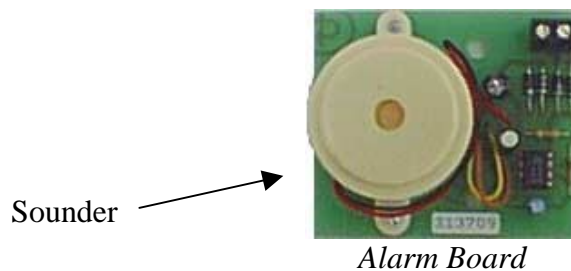

Alarm Board

4.9 Coin-In Sensor

When a coin is entered via one of the coin chutes it triggers an optical switch, which initiates that player section. The coin passes through the beam of an optical sensor, producing a pulse, which initiates that player section.

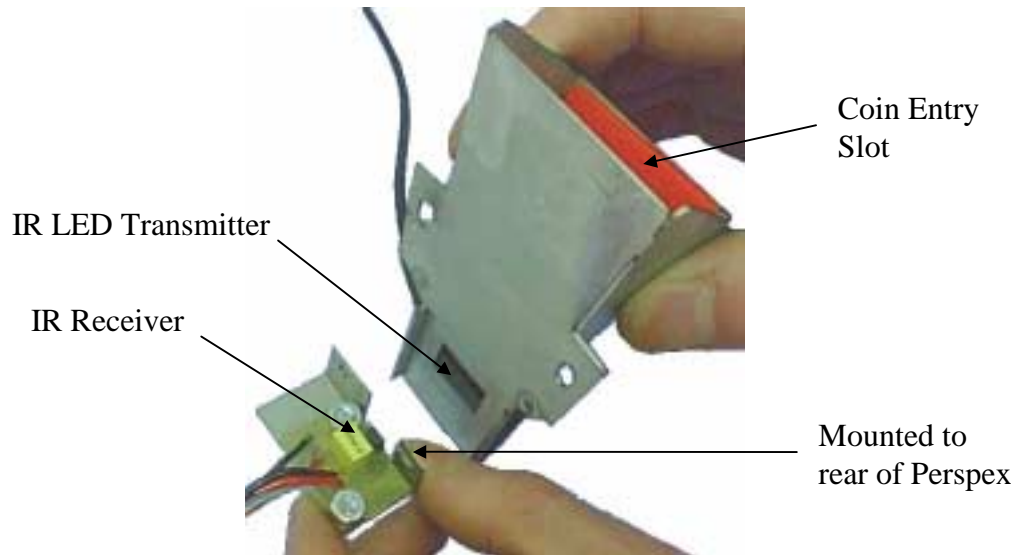

4.10 Counters

Electro-mechanical counters are provided in each player section, located in the coin entry compartment of each section. These counters record the number of coins in tickets issued. Taking readings of these counters regularly will obviously facilitate the monitoring of the machine performance and assist in cash accounting.

4.11 Swipe Change Facility (Optional Fit)

If the machine was purchased with the optional facility to interface with a swipe card change facility, then a change board and interface relay will have been installed. This is 'interface' circuitry, and the swipe card system needs to be installed by a trained person. The supplied installation basically provides for a pulsed input, inhibit relay output and payout hopper control.

There is a free ended yellow wire which is the pulse input (black wire is the zero volt reference for this input) and a green and grey pair of wires which are the volt free contacts of the inhibit relay. These lengths of wire are coiled and secured with cable ties to adjacent machine looming.



Change Board

Program: CHANGE19 V1.4

SW1

		<u>Poles</u>								<u>Function</u>
<u>1</u>	<u>2</u>	<u>3</u>	<u>4</u>	<u>5</u>	<u>6</u>	<u>7</u>	<u>8</u>			
off	off	off	off	off	-	-	-	Poles 1-5 = No. Pulses Out		
on	on	on	on	on	-	-	-	1-32 pulses (Binary + 1)		
					on	-	-	Swipe Mode On		
					off	-	-	Swipe disabled		

SW2

Not Used

SW3

Not Used

5.0 **Cabinet Lighting**

5.1 **Fluorescent Lighting**

WARNING – Dangerous Voltages (115v) - switch OFF prior to replacing!

Fluorescent tube lighting is situated in the top sign area. Lighting trays, also located in the top sign, drive these fluorescent lamps. The tilt board is also located in the top sign area, and this interrupts the electrical supply to the Fluorescent lamps in the event of a tilt or tamper condition.

5.2 **Dichroic Lighting**

Low voltage dichroic spot lamp lighting is situated at the top of each playfield. These lamps are easily replaced by simply pulling the old bulb free from the fitting, and pushing the replacement bulb back in place. These lamps are rated at 35 Watts, and should only be replaced with a similarly rated lamp.

WARNING - These lamps become very hot in operation - allow to cool before handling!

6.0 Mechanical Systems

6.1 Pusher Box Motor Control

This system utilises an opto-electronic method to monitor the motor load, and stop the motor in the event of a restriction/jam.

The motor drive shaft extends some 35mm out of the rear end of the motor case. It is here that the opto sensor PCB is located, secured to the motor case. The motor shaft has a hole drilled in it, through which the infrared beam may pass when correctly aligned. With the rotation of the motor shaft, this results in the beam being continually interrupted, and a resultant string of pulses produced by the opto receiver.

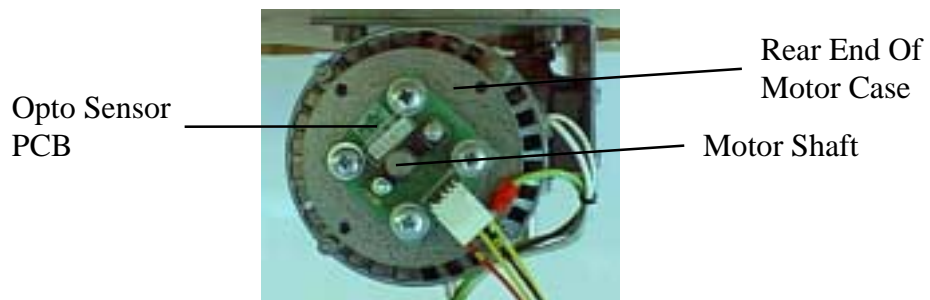

Opto Sensor PCB Mounted To Motor

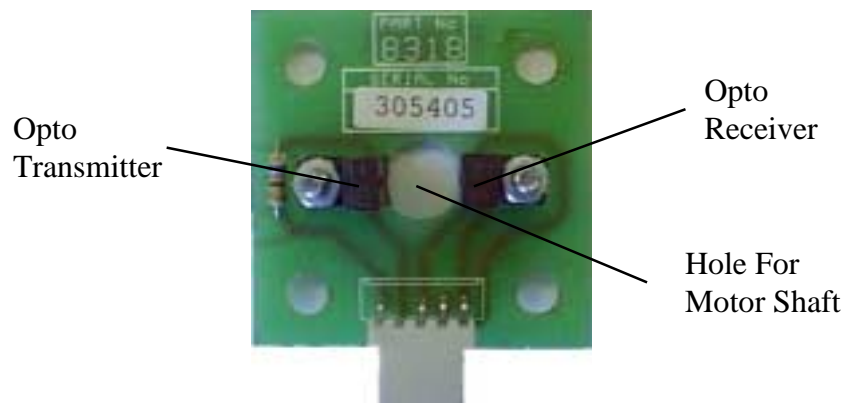

Close Up Of Opto Sensor PCB

The pulses produced by the opto receiver are monitored by the circuitry of the motor control PCB. This control circuit basically monitors for a given number of pulses within a set time frame. Should this number of pulses decrease beyond the tolerated amount, the supply to the motor is immediately switched off via a solid-state relay.

The control of the motor cut off point may be set by way of a 4 way DIP switch mounted on the motor control board thus (located in the power supply unit):

<u>Pole</u>	<u>1</u>	<u>2</u>	<u>Response</u>
	off	off	Fastest
	on	off	2nd Fastest
	off	on	2nd Slowest
	on	on	Slowest

<u>Pole</u>	<u>3</u>	<u>4</u>	<u>Stop Resistance</u>
	off	off	Weakest
	on	off	2nd Weakest
	off	on	2nd Hardest
	on	on	Hardest



When the system operates and stops the motor, the supply to the motor remains off until manual reset is initiated. This creates the opportunity to ensure the machine is in a safe state to re-start; a visual check by the attendant ensuring that there is no longer any item causing the obstruction. Reset of the system is done by depressing the 'Restart' switch on the Motor Control PCB or by way of the remotely located reset switch (mounted on a T-board in the rear of section one).

There is an LED on the Motor Control PCB, which indicates the output of the opto-sensor. In normal operation this will appear to be continuously ON, due to the high repetition rate of the pulses. This facility may be used to check the operation of the sensors, by manually rotating the motor shaft and observing the LED. The LED should turn on then off as the hole in the shaft passes between the sensors.

The 20mm fuse on this PCB is to provide over current protection to the solid-state relay/motor combination (Refer to specific machine manuals for type and rating).

The other relay (RL1) is used to provide a switching function upon system operation, which is used for signalling to other circuits for alarm operation etc.

6.2 Coin Entry

Each player section has three coin entry chutes. The chutes are designed to reject fraud coins into a reject tray just inside the door.

This is not a high level of discrimination, but serves well and reliably in this application. Other than keeping the chutes clear and clean no specific maintenance is required

Coin entry chutes are situated on the front of the machine. The two outside chutes are fixed and require no maintenance. The middle chute is a moving coin chute and should require little maintenance other than a clean and occasional light grease. A little care is required on replacing the coin entry door to ensure the moving mechanism engages correctly.

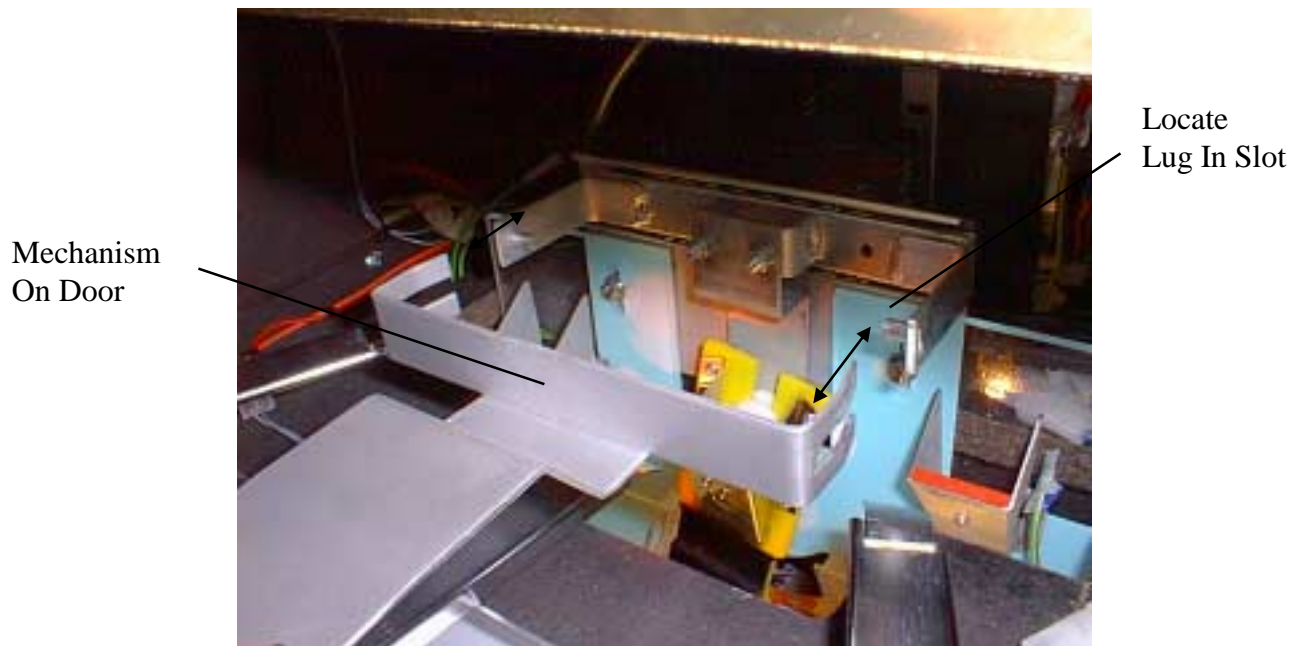

Moving Coin Entry Mechanism

6.3 Pusher boxes

The pusher boxes are mounted on two Accuride slide bearings. An annual check to remove any build up of dust, and a light coat of grease will ensure many years of reliable service.

Ensure that the coin scraper system is fully intact and working smoothly and freely, replace any suspect parts.

7 **Fault Finding**

7.1 **Methodology**

It is of mutual interest that your pusher is kept in excellent working condition, therefore when required please order original replacement parts from your distributor or Harry Levy Amusement Contractor Ltd.

If a fault occurs with any electrical system **SWITCH THE MACHINE OFF**. Check that:-

- a) There is a suitable mains supply.
- b) All fuses are intact.
- c) All plugs and sockets are correctly mated.
- d) No wires are trapped, damaged or broken.
- e) All wires are properly secured to their terminals and pins.

Wiring check.

A visual inspection will reveal the general condition of the wiring. A more thorough test using a continuity tester will be needed to check apparently intact wires, however once a machine has been playing successfully for some time wiring is not usually at fault.

Device testing.

Disconnect the machine from the mains supply then check the physical condition and operation of the suspect device (remove from the machine if necessary). Bench test if possible using a suitable power supply.

In general PCB's are not user serviceable. Should a problem develop indicating a board fault it is recommended that the board be returned to your distributor/Harry Levy for repair.

7.2 Systems Checking

When a fault occurs that affects the whole of the machine, the power supply and regulation system should be investigated first.

Check the input, and output fuses.

Refer to schematics and drawings to check power connections, voltages etc.

If the fault is not visual, or easily measurable it is often helpful to disconnect the outputs from the PSU, check that the PSU is functioning then connect the loads one at a time.

It is easy to identify the faulty system, then use a similar technique within that system (such as disconnecting all hoppers) to identify the faulty component.

7.3 Basic Checks

<u>Symptom</u>	<u>Possible Fault</u>	<u>Remedy</u>
Will not start	Internal switch OFF Fuse blown	Check internal switch is ON Check plug fuse then circuit breakers.
No sound	Volume Speaker Sound board	Adjust volume Check wiring. Replace if faulty Check power supply & connectors, replace board if faulty.
Light failed	Tube failed Starter failed Choke (ballast) failed	Check end caps & wiring Replace tube. Replace with same type. Replace with same rating.
Pusher boxes not moving	Power to motor Mechanical jam	Check for coins or swag causing jam. Clear & reset.
Tilt alarm not working	Pendulum stuck Door bump sensor Sounder Tilt P.C.B	Check pendulum & adjust. Check & adjust. Test connections & power Check connections & power.
Counter not working	Wiring Counter Opto sensor	Check connectors & loom Bench test / replace. Check every opto sensor.
Hopper not working	Hopper motor. Power. Jammed.	Bench test with power supply. Check supply & connections. Check for obstruction.

8 Spare Parts List

This spares list is by no means fully comprehensive; since to provide the full listing would require another volume! The following are some of the more commonly required items that you may need. If the item you require is not listed, please contact either your distributor or Harry Levy Amusements and we will be pleased to assist you.

<u>Description</u>	<u>Harry Levy Stock Number</u>
201 lock & keys	6278
301 lock & keys	6087
Accuride pusher box slide	6081
Circuit Breaker 5A (mains)	8713
Circuit breaker 7.5A (mains)	8714
Circuit Breaker 1.5A	8878
Circuit Breaker 3A	8879
Circuit Breaker 4A	8880
Circuit Breaker 5A	8878
Change board	8988
Counter – standard machine	6029
Electronic alarm board	7819
Fan 12 VDC	8624
Filter – Mains 10A	8180
Hopper – Coastal token	8676
Microphone board	8498
Motor 115V 60Hz	8567
Motor control board	8321
Motor Opto board	8318
Power supply 12V 100W	8859
Power supply 24V 100W	8860
Sound board	8915
Speaker	6979
Starter – FSU (UL)	6119
Switch - ON / OFF / ON	8712
Switch - reset	6127
Switch - pendulum tilt	CC004
Switch – slam tilt	6149
Tilt board	6099
Transformer Dichroic 600VA (UL)	8708

Other items may be available on request.