

# 1 Specifications

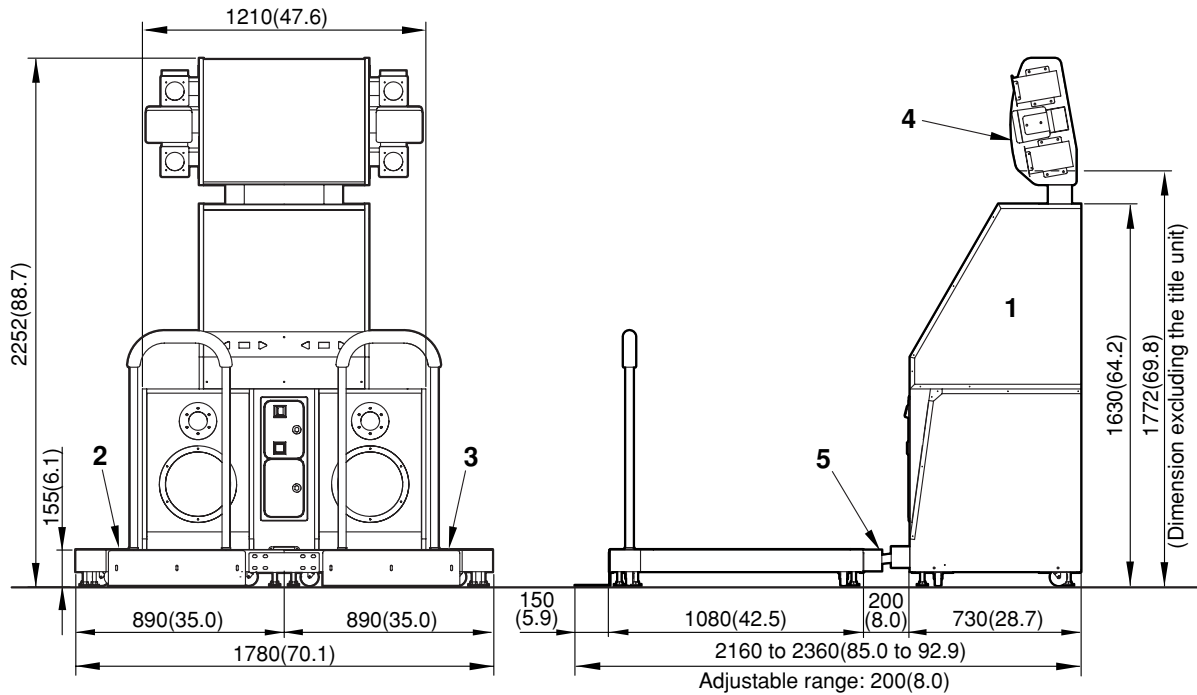

Rated power consumption

## Specifications

Dimensions	Refer to the figure above : mm (in)
Weight	Total weight: Approx.437 kg(964 lb)      1 Cabinet unit: Approx.207 kg(456 lb) 2 Step base unit (L): Approx.100 kg(220.5 lb)      3 Step base unit (R): Approx.100 kg(220.5 lb) 4 Title unit: Approx.28 kg(61.7 lb)      5 Unit connection pipe: Approx.2 kg(4.4 lb)
Rated power consumption	000 W
Monitor	29-inch CRT
Service condition	Temperature 5 to 35°C (41 to 95°F), Humidity 30 to 70% (No dewing is allowed.)
Attachments	<ul style="list-style-type: none"> <li>·Instruction manual ..... This manual</li> <li>·Keys for coin door ..... 2</li> <li>·Keys for maintenance ..... 2</li> <li>·AC power cord ..... 1</li> <li>·Title unit ..... 1</li> <li>·Title unit mounting screw (M6 x 20L) ..... 5</li> <li>·Title unit mounting plain washer (6) ..... 5</li> <li>·Step base plate mounting screw (M6 x 20L) ..... 6</li> <li>·Unit connection pipe ..... 1</li> <li>·How-to-play instruction label ..... 1</li> <li>·Billboard set ..... 1</li> <li>·Hexagon wrench (width across flats: 4 mm) ..... 1</li> </ul>

- If any part is defective or not found, contact your nearest dealer.
- The specifications of this product are subject to change without notice for reasons such as improving the performance.

**■ Allowance for Carrying-in and Installation of Product** — — — — —

The following allowance dimensions are necessary for carrying the product indoors.

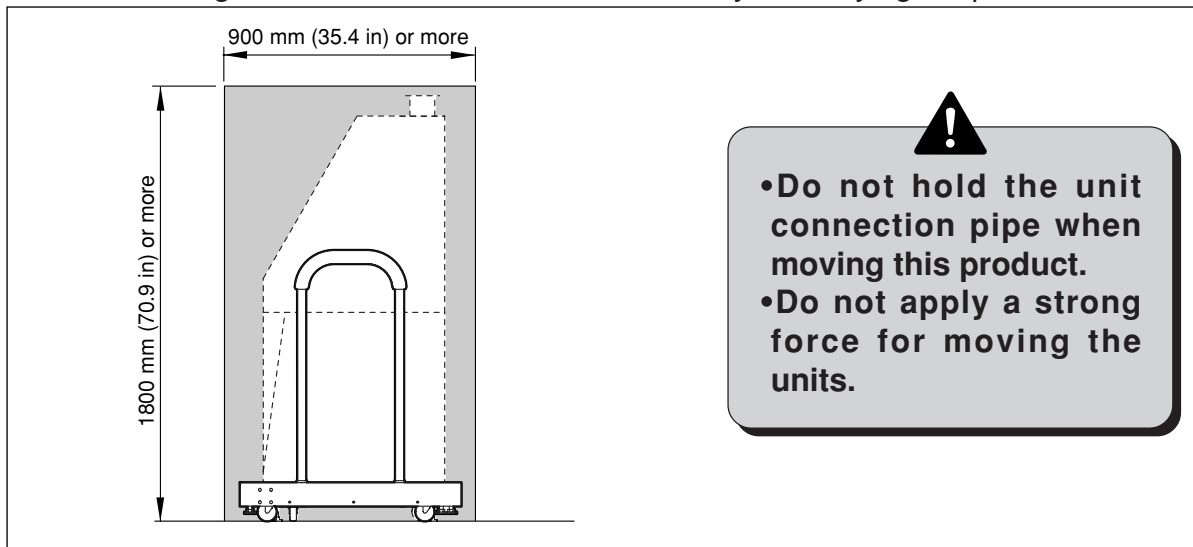

900 mm (35.4 in) or more

1800 mm (70.9 in) or more

- Do not hold the unit connection pipe when moving this product.
- Do not apply a strong force for moving the units.

Provide a space of the following dimensions for installation of the product.

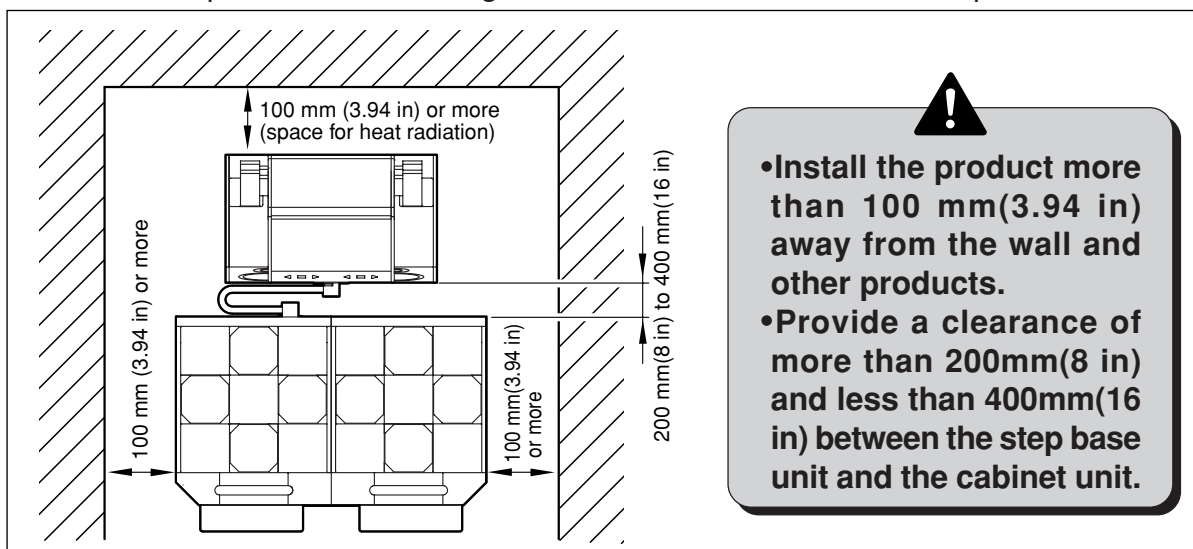

100 mm (3.94 in) or more (space for heat radiation)

100 mm (3.94 in) or more

100 mm (3.94 in) or more

200 mm (8 in) to 400 mm (16 in)

- Install the product more than 100 mm (3.94 in) away from the wall and other products.
- Provide a clearance of more than 200mm (8 in) and less than 400mm (16 in) between the step base unit and the cabinet unit.

Follow the procedure below when heaving up the product.

• More than four persons should heave up the product while holding the handle and supporting the bottom. (Approx. 207 kg / 456 lb)

Never carry the product with its back side being inclined.

Hold handles.

Support bottom

Strictly refrain from moving the product in the manner as follows

Do not remove the back door nor hold the positions indicated by arrows.

Do not hold the positions indicated by arrows.

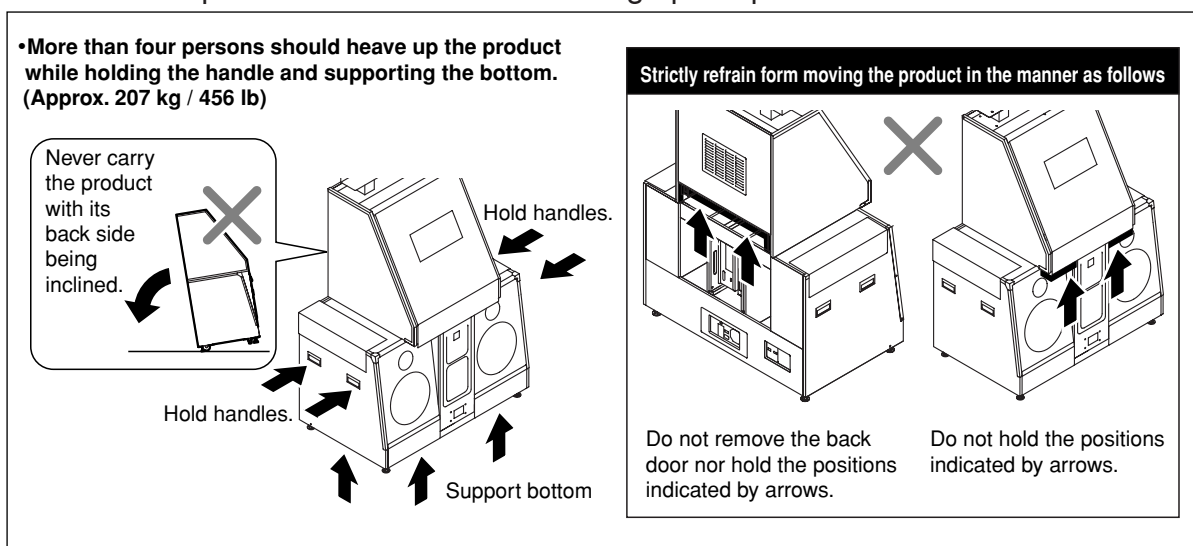

# 2 Names of parts

