



OPERATOR'S MANUAL



Product Specifications

Electrical Power

Domestic	120 VAC @ 60 Hz, 5 amps
International	240 VAC @ 50 Hz, 2.5 amps
Japan	100 VAC @ 50 Hz, 5 amps

DC Power Fuse Guide

ELECTICAL SAFETY NOTICE: REPLACE FUSE WITH SPECIFIED FUSE RATING ONLY. DO NOT REPLACE FUSE WITH HIGHER THAN SPECIFIED RATING.

RIO PCB FUSE GUIDE:

- +5 VDC - 3 amp Slow Blow (RIO MCU, START BUTTON)
- +12 VDC - 5 amp Slow Blow (COIN DOOR, COOLING FANS, DASH LED)
- *+12 VDC - AUDIO POWER USES A THERMAL FUSE, RIO F3

CABINET FUSE GUIDE:

(NOTE: FUSES ARE MOUNTED TO THE LEFT OF THE RIO PCB. F1 IS LOCATED CLOSEST RIO PCB)

- F1 - PLAYER 1 GUN SOLENOID POWER , 5 amp Slow Blow
- F2 - PLAYER 2 GUN SOLENOID POWER , 5 amp Slow Blow
- F3 - DINO HEAD BACKLIGHT, 5 amp Slow Blow
- F4 - JURASSIC PARK GATE LOGO, 5 amp Slow Blow
- F5 - ROOF LED LED T-MOLD, 5 amp Slow Blow
- F6 - BENCH LED T-MOLD, 5 amp Slow Blow

Temperature

32° to 100° Fahrenheit (0° to 38° Celsius)

Humidity

Must not exceed 95% relative humidity or where visible condensation is present.

Cabinet Dimensions

Component	Height	Width	Depth
Assembled 55" Environmental Model	118 in. / 300 cm	53.5 in. / 136 cm	80 in. / 203 cm

Contact Information

For an authorized distributor near you, check the Raw Thrills website at www.rawthrills.com

Contact Betson Enterprise Headquarters or your local Betson office for sales, technical information, warranty or repair. Betson can be reached at (800) 524-2343 Fax (201) 438-4837 www.betson.com

Betson Enterprises Headquarters

303 Paterson Plank Rd.

Carlstadt, NJ 07072

(800) 524-2343 or (201) 438-1300

fax (201) 438-4837

<JP environmental cabinet image>

Safety

OPERATION

Before operating game, read this manual. Failure to properly install and operate this game could result in malfunction or accident. Operate the game in accordance with the manual.

TRANSPORTING

Cabinet is very heavy and contains fragile components. Use appropriate care when moving or transporting cabinet. Avoid rough handling.

HANDLING COMPONENTS

Many components are extremely sensitive to handling, environmental and Electrostatic Discharge (ESD) events—especially the computer. Do not handle it roughly. Before servicing, call your distributor and inquire about the PC warranty. Use proper ESD procedures when servicing. Protect components from harmful environmental conditions, such as extreme temperatures, excessive moisture or other damaging effects.

DISCONNECT POWER

Always turn off power and unplug the unit before servicing or making adjustments, unless otherwise instructed. Installing or repairing components while power is on can damage the components and void the warranty.

GROUNDING

Avoid electrical shock. Do not plug in AC power until you have inspected and properly grounded the unit. Only plug into a grounded, three-wire outlet. Do not use a “cheater” plug or cut off the ground pin on the line cord.

ELECTRICAL SHOCKS

There is no isolation transformer in the cabinet. Disconnect AC power before servicing. However, be aware that lethal voltages can remain in the electronic components even when AC power is disconnected. Use extreme caution when servicing. Verify that there is a working ground connection. If the unit sustains water damage, cease using it immediately and unplug AC power.

MONITOR

Extremely high voltages exist in the monitor at all times. These high voltages exist even when the monitor is off and the AC line cord is disconnected. These voltages are extremely lethal and will cause death. The monitor contains no user serviceable parts. Do not attempt to service the monitor.

POWER SELECTOR

Before installing game, ensure the voltage on the PC is set properly. There is a 115/230 VAC selector switch that must be set for the correct voltage for your site. Verify the fluorescent lamp rating. The rating must match the line voltage at the installation site.

CONNECTORS

Ensure all connectors mate properly. If connectors do not slip in easily, do not force them. Connectors are often keyed and only connect one way. Check for correct orientation.

COMPUTER

The computer contains sensitive components, including a hard drive. Do not handle it roughly. Call your distributor before servicing its internal components. Ask about warranty information as it relates to the PC.

Do not turn the PC power switch on or off. It should remain permanently in the ON position.

Cycle AC power on or off with the cabinet power switch.

A dongle has been inserted into one of the USB ports. This is required for game play.

Do not remove the dongle except for troubleshooting purposes.

POWER CORD

If the power cord is damaged or lost, replace it with an identical cord as supplied by the manufacturer or an authorized service agent.

WATER JETS

Do not install or operate game within operating perimeter of a water jet. Do not clean equipment using water jet.

HAZARD TO EPILEPTICS

A small portion of the population has an epileptic condition that may cause seizures. Affected persons experience seizure while watching some television pictures or playing certain video games. People who have not had seizures may still have an undetected epileptic condition. If anyone in your family has experienced epilepsy symptoms (seizures or loss of awareness), consult your physical before using video games. While children play video games, a parent should observe. Be alert to the following symptoms: dizziness, altered vision, eye or muscle twitching, involuntary movements, loss of awareness, disorientation or convulsions. If you or your child experiences these symptoms, discontinue use immediately and consult your physician.

MANUAL

Keep this manual available and ready for use. If the game fails to function properly, turn off the machine and unplug the AC line cord. Contact your local distributor. Your warranty, when applicable, lasts 60 days from your purchase date. You may not reproduce this document or any of its contents without written authorization from Raw Thrills™, Inc.

SPECIFICATIONS

For reasons such as performance, this product's specifications may change without notice. Federal patent, copyright and other intellectual property laws protect the content, devices and design of the game and its equipment.

Cabinet Setup

SAFETY NOTICE:

Installing this product requires two individuals able to lift heavy objects safely. You will also be required to climb a ladder as part of the installation process. Make sure that you are familiar with the manual contents and game set up and operation before you begin the installation process. Do not push or pull the on the guns or decorative items such as the marquee or bench log to move the game. Doing so can damage the gun mechanism or decorative items. Be aware of your surrounding and individuals around you during the installation process for your safety and others. Work only in area with sufficient lighting and a clean and level surface.

Unpack Cartons

1. Place the shipping crates on a flat stable surface.
2. Cut the banding straps and remove the cardboard lids.
3. Lift off the large cardboard container surrounding the cabinet and any shipping cleats.
4. With at least two people and a dolly, remove the cabinet from the shipping pallet. See model specific assembly diagram.
5. Remove the coin door key from the coin return chute.
6. Open the top coin door.
7. Locate the key for the top and bottom back doors and the cash box.
8. Remove the items inside cash box: AC power cable, a bag of screws and tools, marquee power cable, this manual.

Check Electrical Settings (For Units Shipped From Different Location)

1. Verify the voltage in the nearest AC outlet.
2. Verify the AC outlet ground connection is present and working.
3. Open the lower back door of the monitor assembly.
4. Verify the voltage selector switch is set to correct AC voltage for all power supplies. This step is recommended if the unit has been moved or shipped from another locality.
5. Route the line cord so that the plug is near the AC outlet and out of the way of traffic.
6. Replace the back door of the monitor assembly.

Start Up Game

1. Plug in line cord to AC outlet.
2. Turn the power switch to ON.
3. Check that no component is excessively hot or emitting foul odors.
If not, turn off AC power and disconnect line cord. Refer to the diagnostic section of this manual.
4. Once software loads, you will be asked to calibrate the guns.
If not, enter the service menu by pressing the TEST button located on the bracket inside the top coin door.

Cabinet Setup

55" ENVIRONMENTAL MODEL ASSEMBLY ILLUSTRATION

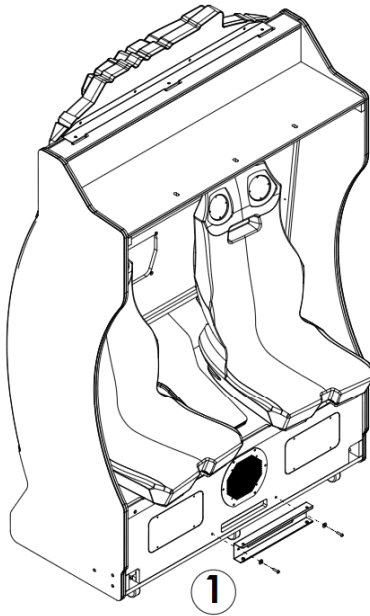

NOTE: ALL FASTENERS ARE T27-1/4-20 EXCEPT FOR STEP 1 AND 5 WHICH USE PHILIPS HEAD SCREWS

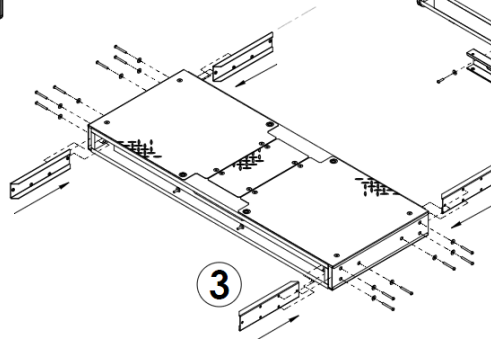
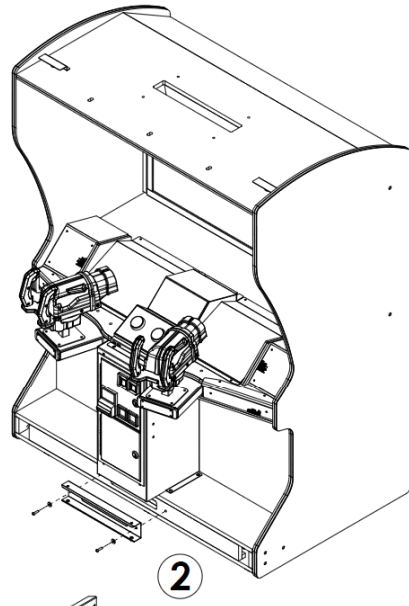

NOTE: DO NOT FULLY TIGHTEN SCREWS FOR STEP3 UNTIL ALL SCREWS FOR STEP 4 ARE IN PLACE.

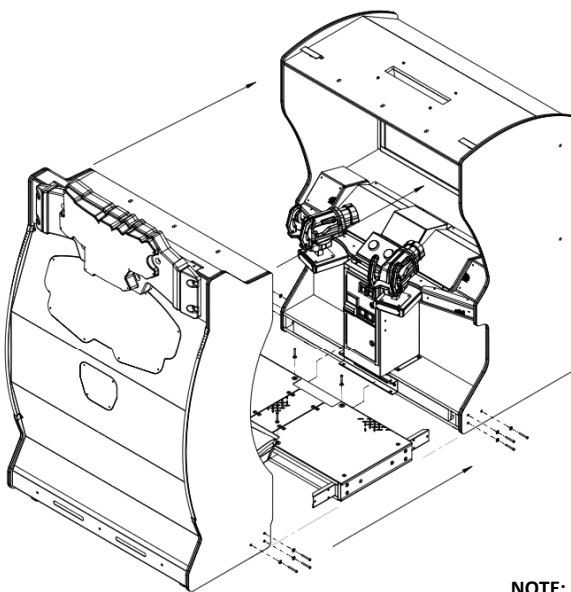

NOTE: MAKE ELECTRICAL CONNECTIONS FOR SEAT AND LCD CABINET TO THE INTERFACE HARNESS FOUND INSIDE THE FLOOR ASSEMBLY.

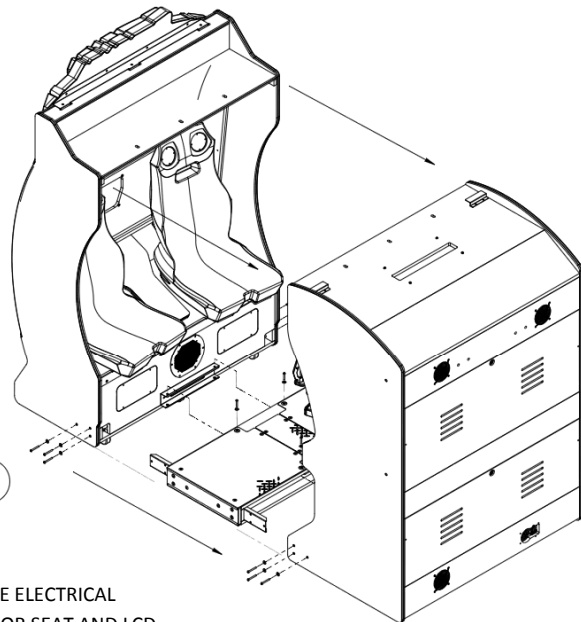

NOTE: CONNECTION FOR DINO
TOPPER IS BEHIND THE LCD.
CONNECTION FOR THE ROOF LED
IS ON THE TOP RIGHT OF LCD
CABINET

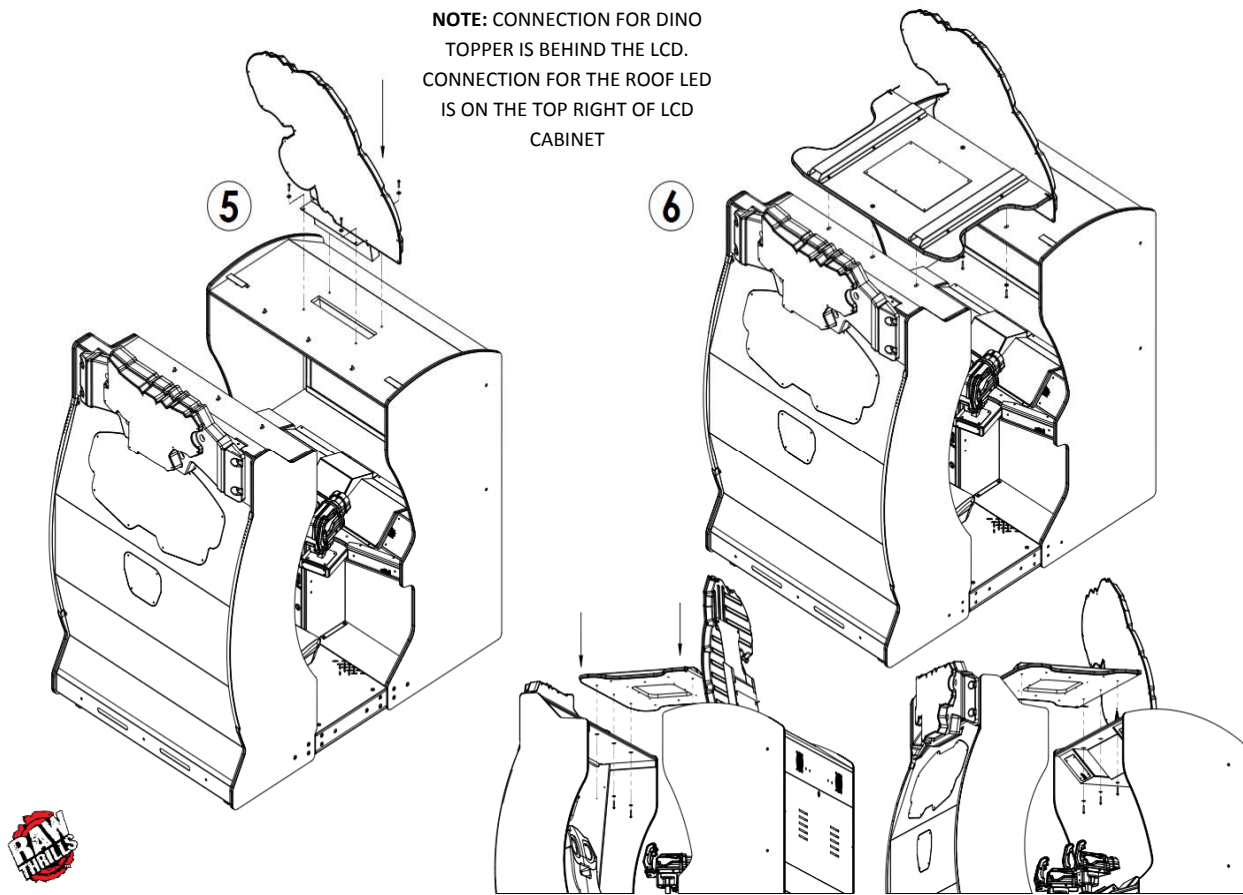

Diagnostic Menu System

Diagnostic Menu Interface

The Service Panel has two rocker type momentary ON buttons. Press the switch UP/DOWN toward the direction of the function you wish to perform. Pressing the TEST button at any point while the game is running will enter the diagnostic menu. This menu can be navigated with the service panel or the gun.

An on-screen message acknowledges changes or when you exit a selection without making a change.

At the bottom of each screen, there is a brief description of the highlighted menu option.

Navigating with Service Panel Switches

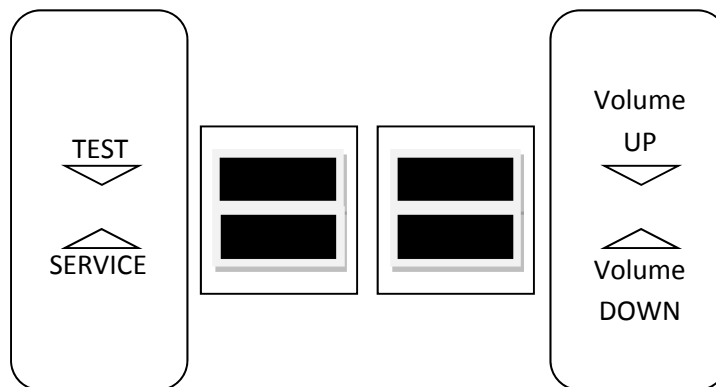

- TEST enters diagnostic system or select highlighted menu option
- SERVICE exit current menu
- VOLUME DOWN moves down through menu or setting choices
- VOLUME UP moves up through menu or setting choices

Navigating with Gun

- The menu interface can be navigated with the gun by aiming and shooting.
- Shooting the right side options will perform the indicated action.
- Shoot scroll up or scroll down to highlight menu options.
- Shoot select to enter the highlighted menu or perform the highlighted option.
- Shoot exit to return to the prior menu or exit the diagnostic system.

Menu Screens and Descriptions

Main Menu

- **Diagnostics** - verify game inputs and outputs are functional
- **Pricing** - view various tracking statistics
- **Game Adj** - setup and manage game parameters
- **System Adj** - setup and manage system parameters
- **Audits** - view various hardware and software information ie. collection and play data
- **Gun Cal** - calibrate and verify gun functionality
- **Game Vol** - adjust game and attract volume

**This document will be updated periodically to improve accuracy and usability.
Please visit: rawthrills.com to get the latest version of this manual.**

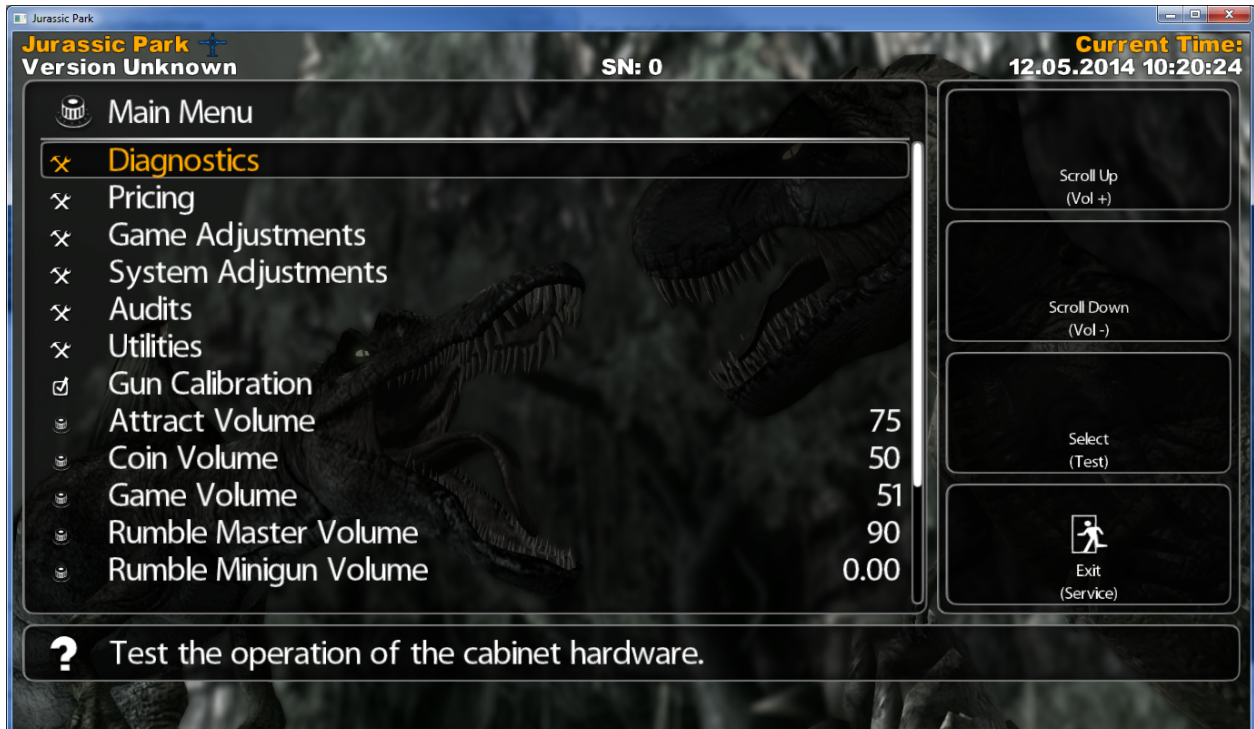

Operator's Manual

Main Menu

Diagnostics

Switch Tests

Periodic checks of all game inputs are key to maximizing earnings, customer enjoyment and safety.



Main Menu

Diagnostics

Sound Test

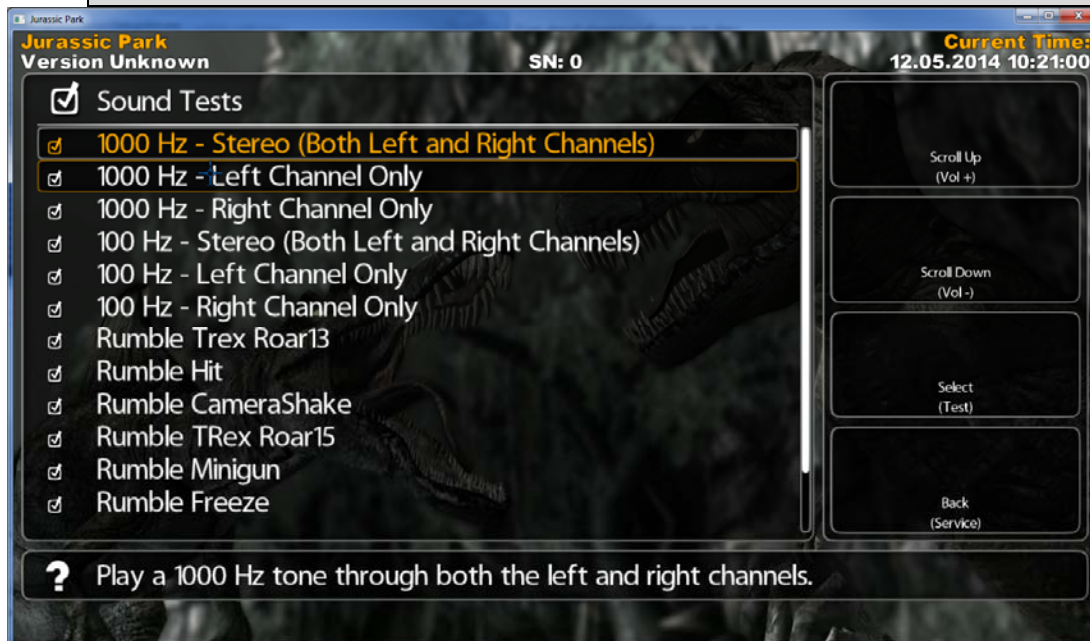

Operator's Manual

Main Menu

Diagnostics

Light Tests

Increase your game's curb appeal while also offering the best visual experience for players and prospective customers by making sure that all controlled lighting effects are working.



Main Menu

Diagnostics

Gun Vibration Tests

The gun mechanical feedback system is designed with unique features that enhance the player's experience. Verify that gun vibration special effects are functional.

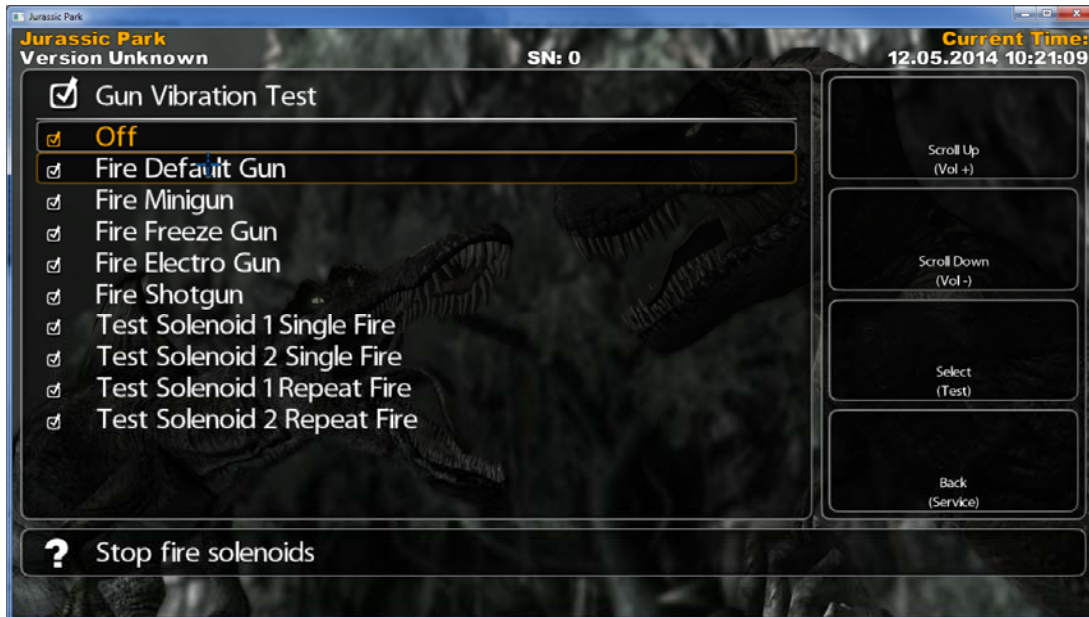

Operator's Manual

Main Menu

Diagnostics

Color Bar LCD Display Test



Main Menu

Diagnostics

Motion Tests (Jurassic Park Arcade Motion Models Only)

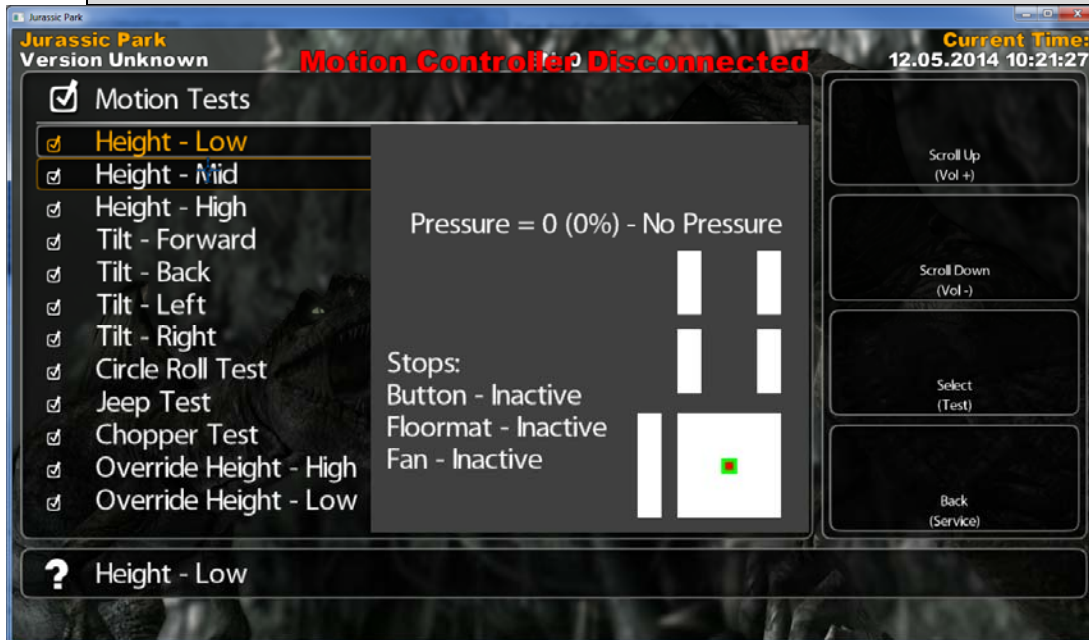

Operator's Manual

Main Menu

Diagnostics

Watchdog Tests

The watchdog function is a critical part of making sure that the game is able to recover from a lock-up condition automatically. This is especially critical in unattended locations.



Main Menu

Diagnostics

Motion Self Tests (Jurassic Park Arcade Motion Models Only)

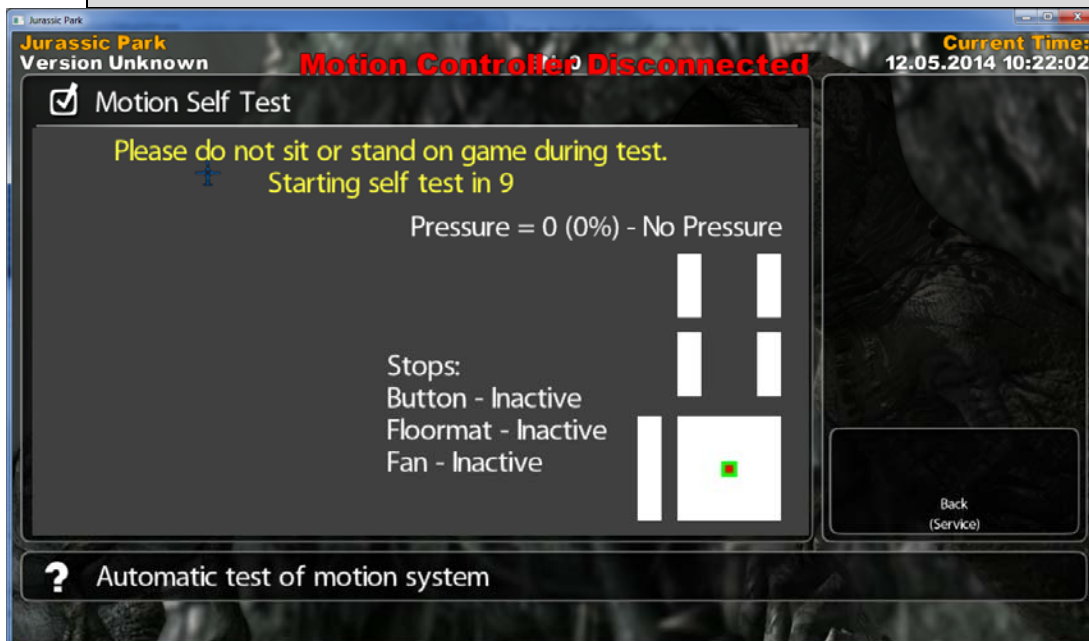

Operator's Manual

Main Menu

Diagnostics

Motion Calibration (Jurassic Park Arcade Motion Models Only)

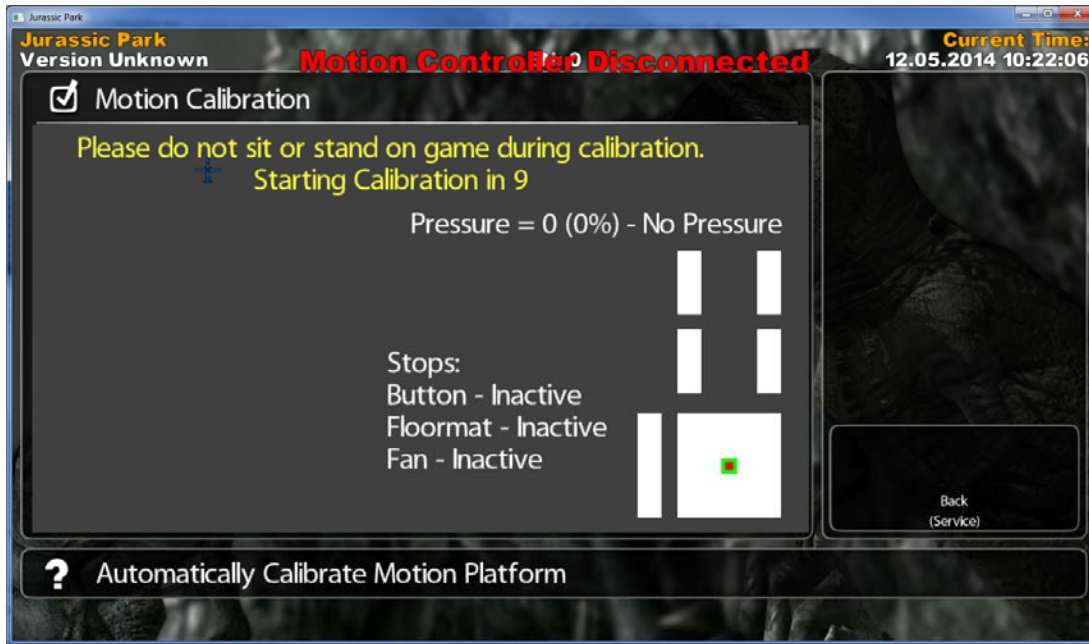

Main Menu

Diagnostics

Coin Meter Tests

This unit has a common meter for coin and DBV accounting. Replace with 5VDC meter only.



Operator's Manual

Main Menu

Pricing

Adjust game pricing and crediting parameters. Customize pricing for best location earnings.

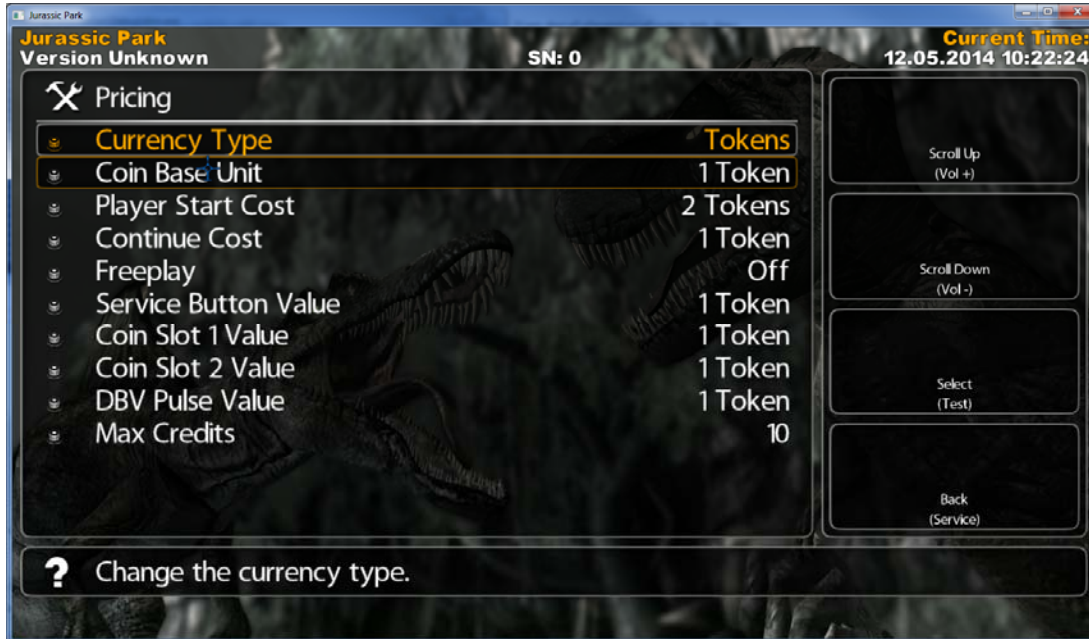

Main Menu

Game Adjustments

Adjust in-game parameters. Customize in-game features to suit customer base and location.



Operator's Manual

Main Menu

System Adjustments

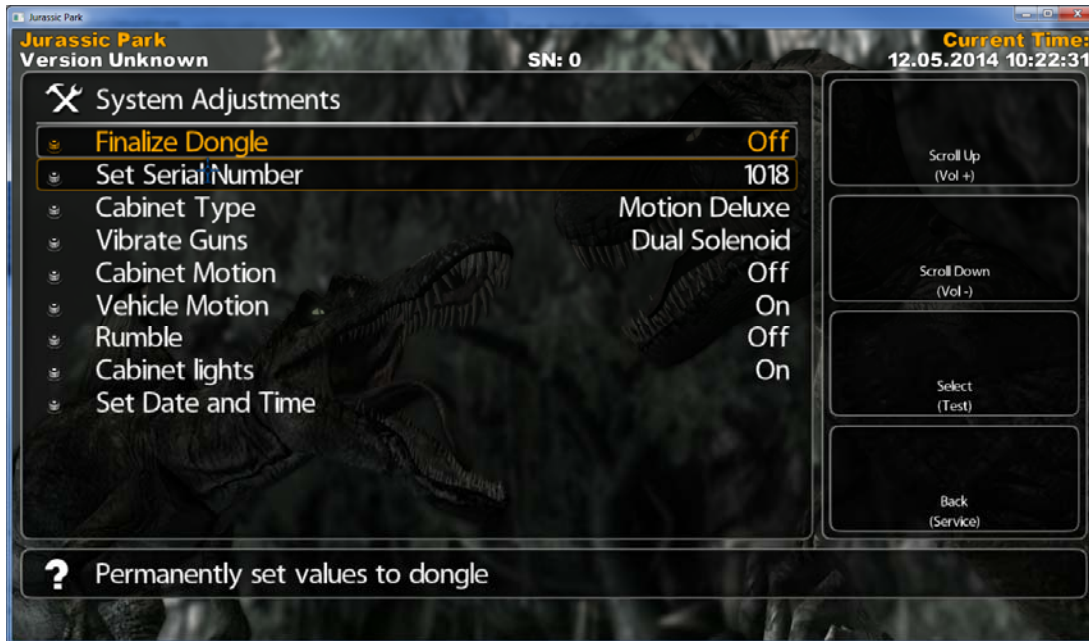

Main Menu

Audits

Monitor game audits to make informed decisions in determining key game settings. ie. pricing, game length.

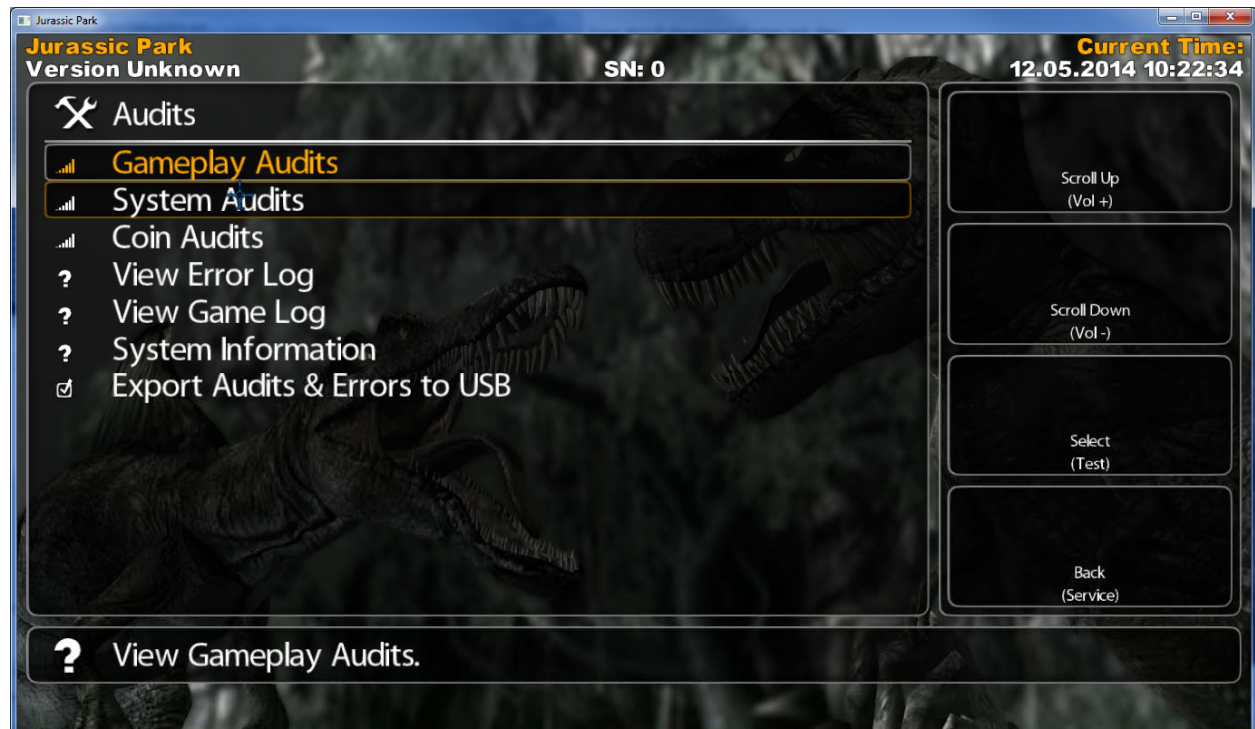

Main Menu

Utilities

Resetting Audit information is recommended whenever you change a game parameter in order to accurately track changes in earnings.

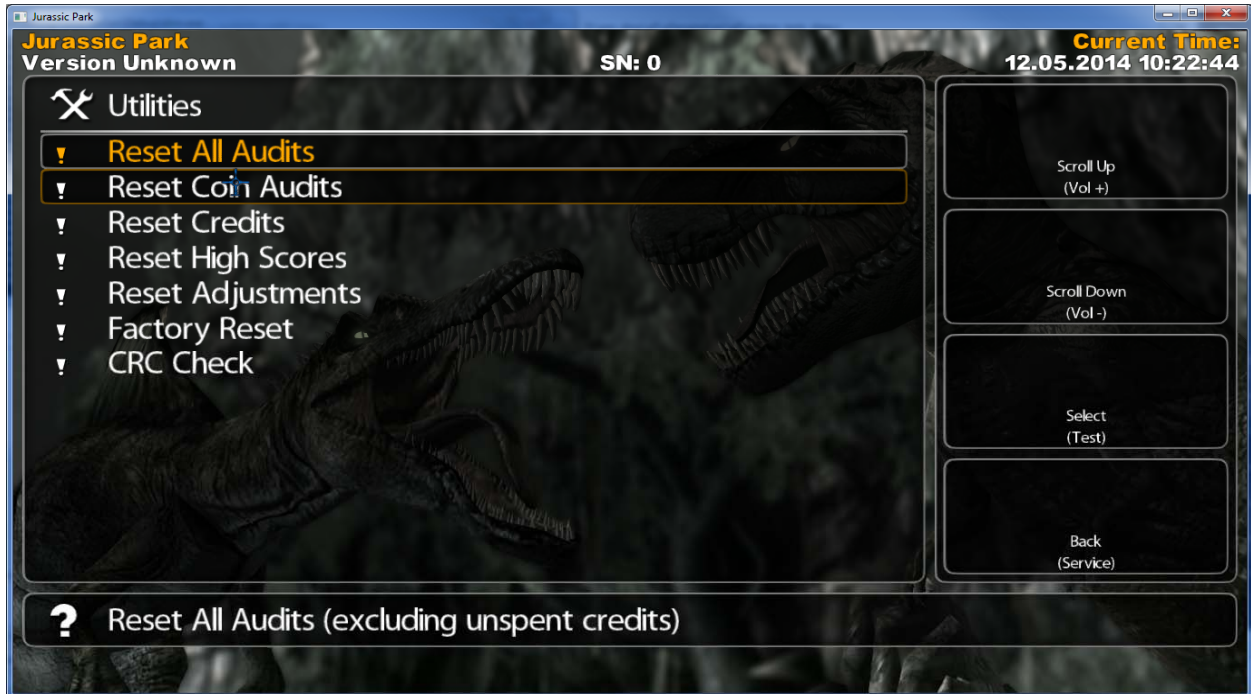

Main Menu

Gun Calibration

Maximize your games earning potential by making sure that the guns are periodically calibrated and all switch inputs are functional.

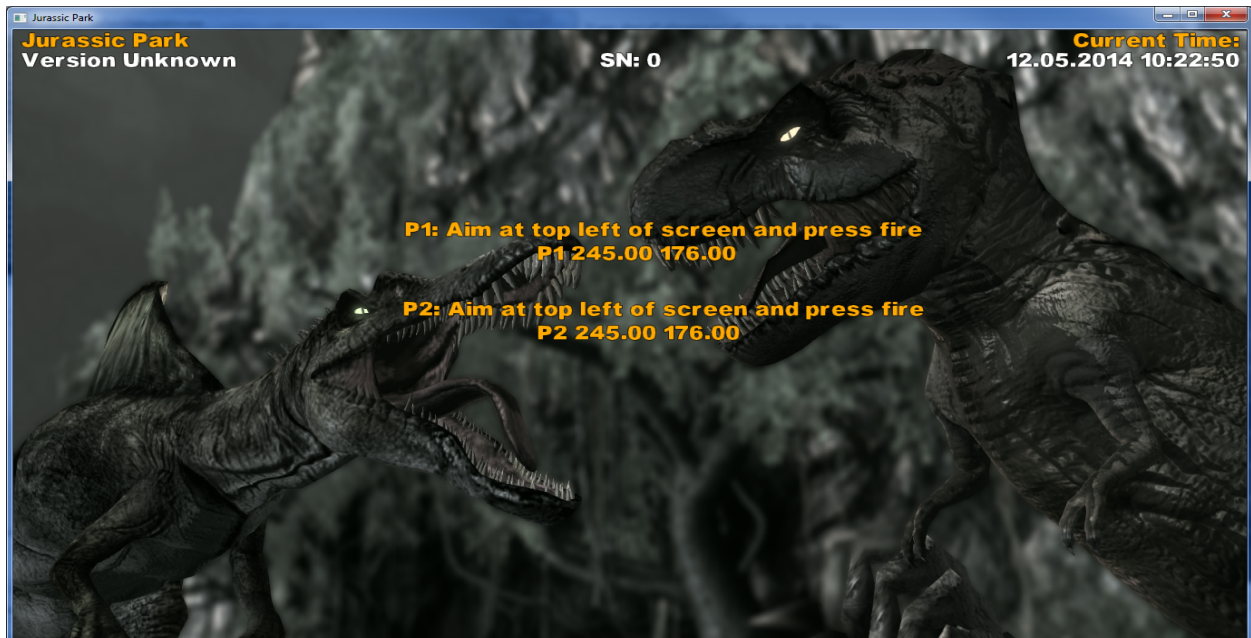

Troubleshooting

Warning: Review safety chapter before making any adjustments to game.

General Troubleshooting

Problem	Possible Cause	Solution
Game will not power up	Game not plugged in.	Plug game into outlet.
	Game not turned on.	Turn on main power switch.
	Game fuse is blown.	Check and replace fuse.
	No power to receptacle.	Test outlet and plug game into powered outlet.
	PC not turned on.	Turn PC power switch on. Ensure IEC cable tightly plugged in. Trace cable back to source to ensure continuity.
	PC BIOS set incorrectly.	See BIOS Settings chapter.
Screen not powering on with game	No AC power or bad video cable	Check loose or bad AC or video connection
NO VIDEO message	Video cables not plugged in properly PC did not power up	Reattach and/or tighten video cable to monitor. Reattach and/or tighten video cable to PC. Power cycle PC or game
	Faulty video cable	Replace video cable
	PC not turned on.	Turn PC power switch on.
No sound	Bad Connection from PC to RIO audio or bad speaker connection.	Check connection ¼" stereo cable from PC to RIO and speakers.
Game does not load	Hard drive failure	Recover hard drive.
Hard drive test reports "bad" or "missing" files.		
Game fails to finish loading.		
After resetting, game still reports an error.		
Game suggests inserting a boot DVD.		
Erratic game mode or attract mode.		
<p style="text-align: center;">WARNING! Data Files Corrupted. (Game Operation May Become Unstable.) Use "Test" Switch to Enter Test Mode and Run "File Test." Press Start To Continue.</p>		

Operator's Manual

Game resets	Bad file or bad 5V RIO fuse.	Run File Test. Restore hard drive. Replace 5V fuse on RIO pcb.
-------------	------------------------------	---

Problem	Possible Cause	Solution
Guns won't register or function poorly	Bad calibration	Calibrate guns.
	Dirty/damaged potentiometers	Inspect and or replace potentiomer
	Gun/pot. disconnected	Check gun/pot connections.

Coin meter does not click during Test	No pulse to meter	Check all wiring from meter to I/O board
	Faulty meter	Replace coin meter

Exits Test Mode every 3 seconds	Test button stuck in ON position	Slide or toggle button off after Test Menu appears
---------------------------------	----------------------------------	--

<i>Dongle Not Present</i>	Dongle missing or disconnected	Find dongle USB connection and reseal in USB port
	Faulty USB port	Connect dongle to another USB port

<i>Connect I/O Board or I/O Board Missing</i>	USB cable disconnected	Check USB connection from PC to I/O board Try connecting to a different USB port
	Blown fuse	Verify 5V and 12V fuses are not blown
	No power to RIO board	Check for proper voltage (+5V, +12V) at RIO P2 connector
	Bad RIO Board	Replace RIO board with known functional board
	Missing Field/Earth Ground	Check AC line cord for missing or damaged ground plug or connection. Use only properly grounded AC power outlet.
<i>Guns not vibrating</i>	Bad fuse or 24VDC power supply. Bad recoil pcb.	Verify parts are bad and replace.
<i>Seat subwoofer sound is weak.</i>	Low voltage on 12V power supply. Volume set too low.	Adjust power supply voltage. Set Volume for desired vibration effect.
<i>Light feature is not lighting up.</i>	Bad connection or damaged wires. Bad fuse or power supply. SEE FUSE CHART.	Replace or repair damaged wires or connectors. Replace bad fuse with correct value.

MECHANICAL AND ELECTRICAL DIAGRAMS

REV.	DESCRIPTION	DATE
A	RELEASED	10/18/14
B	REVISED	1/9/15

ITEM NO.	PART NUMBER	DESCRIPTION	QTY.
1		UPPER VACFORM ASSEMBLY	1
2	SEE PAGE 3	SHAKER ASSEMBLY	1
3		GRIP ASSEMBLY	2
4	600-01422-01	PIN PLATE	1
5	600-01423-01	COVER BRACKET	1
6	600-01495-01	FRONT VACFORM BRACKET	1
7	600-01411-01	GRIP PLATE WELDMENT	1
8	600-01420-01	LARGE GEAR	1
9	600-01491-01	POT BRACKET	1
10	MMC 96075A211	1/4-20 X 1/2" BLK TP SCREW	18
11	MMC 96075A183	10-32 X 3/8" BLK TP SCREW	10
12	MMC 90273A827	10-32 X 3/8" FLAT HEAD SCREW	6
13	MMC 91251A337	10-32 X 5/16" CAP SCREW	8
14	MMC 6384K369	3/4" FLANGED BEARING	2
15	MMC 90126A036	3/4" WASHER	1
16	MMC 91342A240	3/4" LOCKNUT	1
17		CABLE CLAMP	2
18	600-01567-01	SMALL POT GEAR	1
19	HAPP 50-2670-01	POT - 5K	1
21	SEE PAGE 2	LOWER MECH ASSEMBLY	1

TOP ASSEMBLY

NOTES:
 1) ALL SCREWS SHOULD BE INSTALLED WITH BLUE LOCTITE 242 or 243.
 2) THE 3/4" LOCKNUT (16) IS TIGHTENED UNTIL THE TOP IS FLUSH WITH THE TOP OF THE TUBE IN THE LOWER MECH ASSEMBLY (21).

RAW THRILLS INC.	
JP GUN MAIN ASSEMBLY	
REV.:	DATE:
DESIGNER:	DATE:
DRWING:	DATE:
APP'D:	DATE:
REV.:	DATE:
PAGE:	OF:

REV.	DESCRIPTION	DATE
A	RELEASED	11/17/10

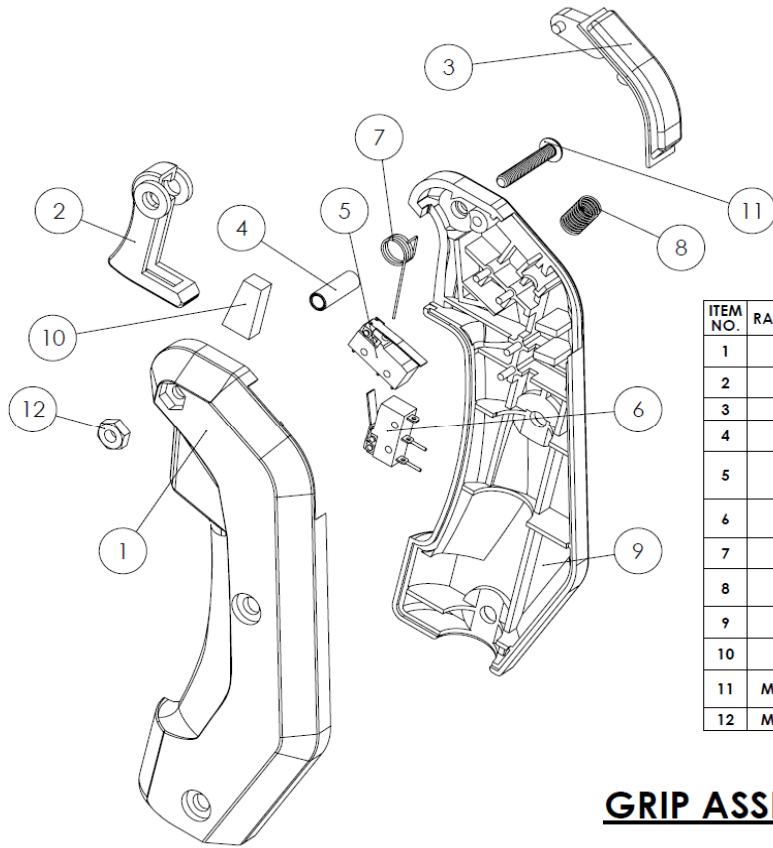

ITEM NO.	RAW PART NUMBER	HAPP NUMBER	DESCRIPTION	QTY.
1	608-00201-01	95-1294-00	GRIP, LEFT HALF	1
2	608-00204-01	95-1295-00	TRIGGER, RED	1
3	608-00203-01	95-1439-00	LARGE THUMB BUTTON	1
4	608-00205-01	95-1315-00	SHAFT, TRIGGER	1
5	608-00216-01	95-0259-00	SWITCH ASSY FOR THUMB SWITCH	1
6	608-00215-01	95-0028-00	SWITCH ASSY. FOR TRIGGER	1
7	608-00206-01	95-1297-00	SPRING, TORSION	1
8	608-00207-01	95-1298-00	SPRING, COMPRESSION	1
9	608-00202-01	95-1293-00	GRIP, RIGHT HALF	1
10	608-00218-01	96-0110-00	TRIGGER BUMPER	1
11	MMC 96075A147	43-0378-00	SCREW, #8-32 x 1 TP BLACK	1
12	MMC 86537A140	43-1124-00	HEX NUT #8-32 BLACK	1

GRIP ASSEMBLY

RAW THRILLS INC.	
TITLE: GRIP ASSEMBLY	
DESIGNED BY:	DRAWN BY:
CHECKED BY:	DATE:
APPROVED BY:	REV. NO.:
DATE:	REV. A

REV.	DESCRIPTION	DATE
A	RELEASED	10/18/14
B	REVISED	1/9/15

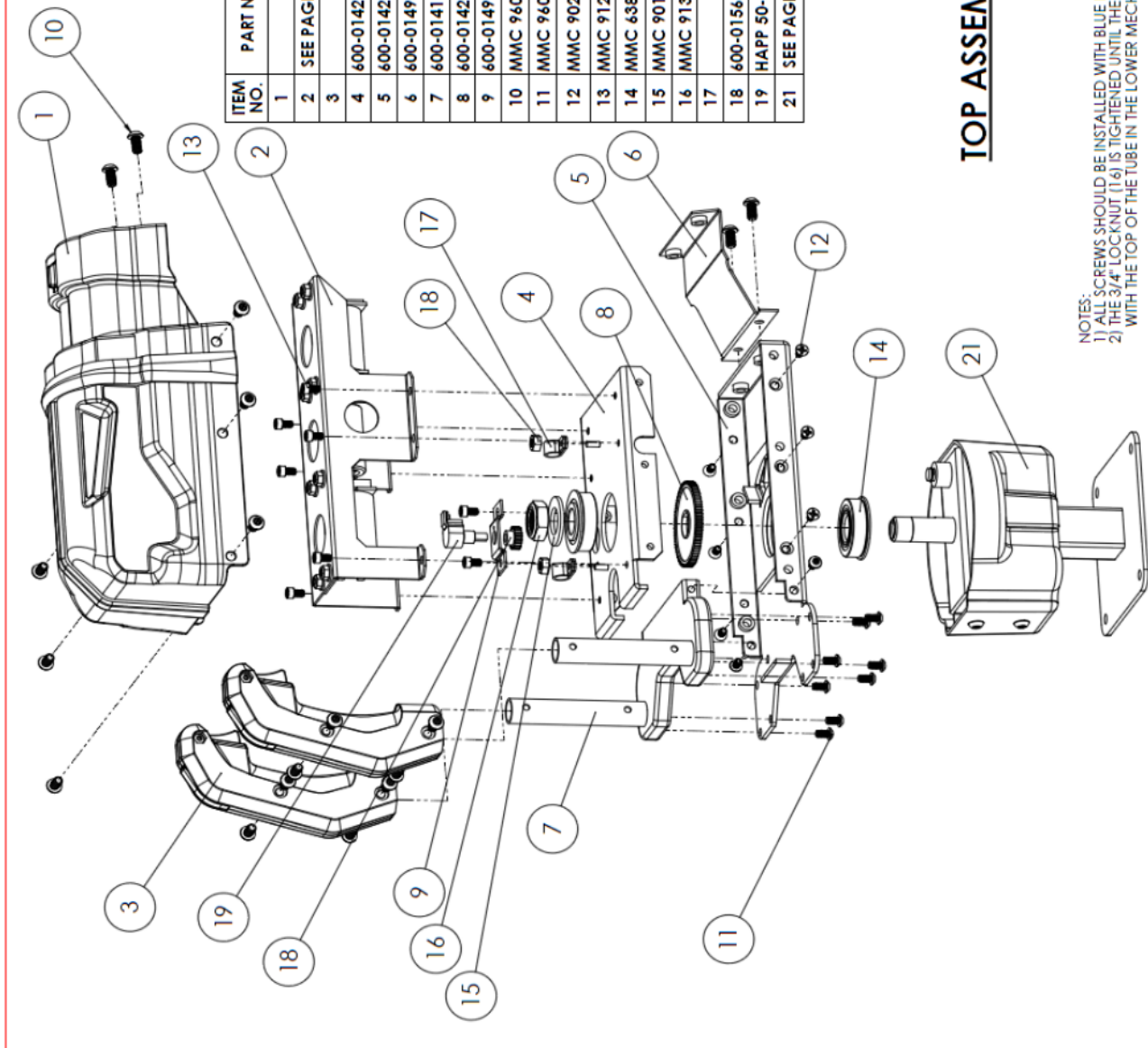

ITEM NO.	PART NUMBER	DESCRIPTION	QTY.
1		UPPER VACFORM ASSEMBLY	1
2	SEE PAGE 3	SHAKER ASSEMBLY	1
3		GRIP ASSEMBLY	2
4	600-01422-01	PIN PLATE	1
5	600-01423-01	COVER BRACKET	1
6	600-01495-01	FRONT VACFORM BRACKET	1
7	600-01411-01	GRIP PLATE WELDMENT	1
8	600-01420-01	LARGE GEAR	1
9	600-01491-01	POT BRACKET	1
10	MMC 96075A211	1/4-20 X 1/2" BLK TP SCREW	18
11	MMC 96075A183	10-32 X 3/8" BLK TP SCREW	10
12	MMC 90273A827	10-32 X 3/8" FLAT HEAD SCREW	6
13	MMC 91251A337	10-32 X 5/16" CAP SCREW	8
14	MMC 6384K369	3/4" FLANGED BEARING	2
15	MMC 90126A036	3/4" WASHER	1
16	MMC 91342A240	3/4" LOCKNUT	1
17		CABLE CLAMP	2
18	600-01567-01	SMALL POT GEAR	1
19	HAPP 50-2670-01	POT - 5K	1
21	SEE PAGE 2	LOWER MECH ASSEMBLY	1

TOP ASSEMBLY

NOTES:
 1) ALL SCREWS SHOULD BE INSTALLED WITH BLUE LOCITITE 242 or 243.
 2) THE 3/4" LOCKNUT (16) IS TIGHTENED UNTIL THE TOP IS FLUSH WITH THE TOP OF THE TUBE IN THE LOWER MECH ASSEMBLY (21).

RAW THRILLS INC.	
FILE: JP_GUN_MAIN_ASSEMBLY	
DATE: 10/18/14	
DESIGNED BY: JEFF HOFFER	
DRAWN BY: JEFF HOFFER	
CHECKED BY: JEFF HOFFER	
REV: 1 OF 1	B

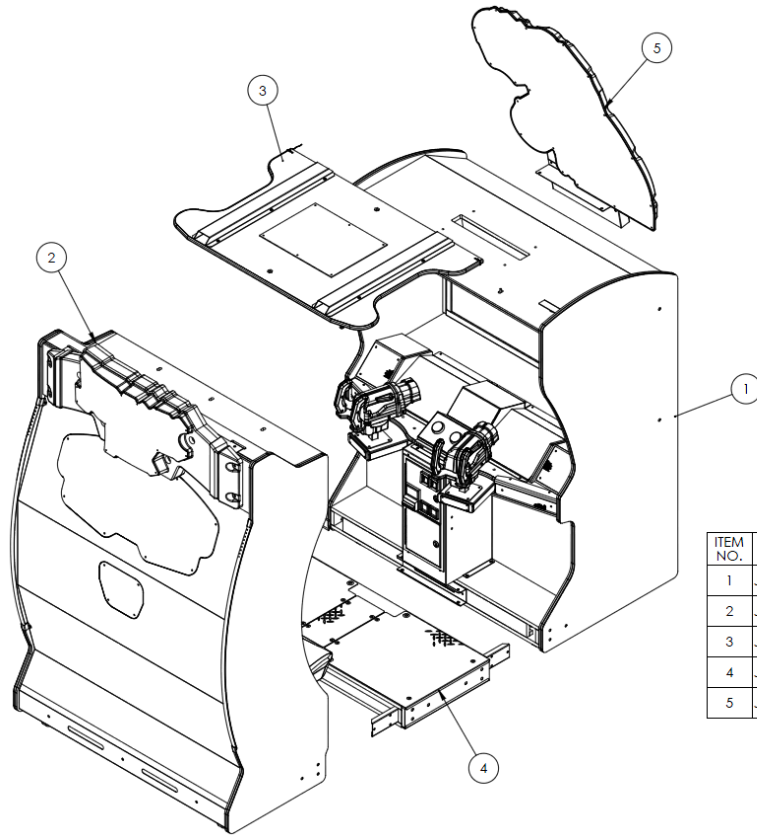

ITEM NO.	PART NUMBER	DESCRIPTION	QTY.
1	JP-55-MAIN-CAB-ASSY	JP-55-MAIN-CAB-ASSY	1
2	JP-55-SEAT-CAB-ASSY	JP-55-SEAT-CAB-ASSY	1
3	JP-ROOF-ASSY	JP-ROOF-ASSY	1
4	JP-55-FLOOR-BOX-ASSY	JP-55-FLOOR-BOX-ASSY	1
5	JP-55-DINO-MARQUEE-ASSY	JP-55-DINO-MARQUEE-ASSY	1

**JURASSIC PARK-55-ENVIRONMENTAL
FINAL ASSEMBLY**

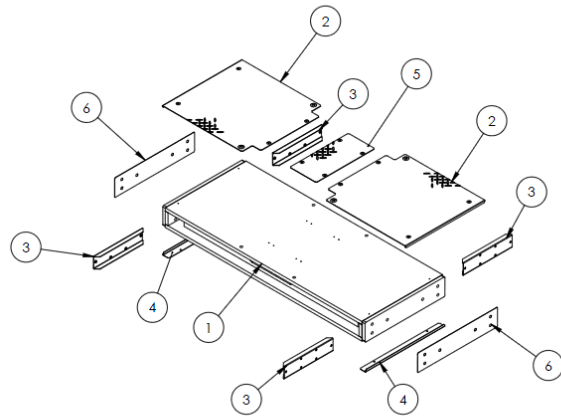

ITEM NO.	PART NUMBER	DESCRIPTION	QTY.
1	601-00704-01	JP-WOOD-FLOOR-BOX	1
2	600-01471-01	JP-55-DIAMOND-PLATE	2
3	600-01457-01	JP-55-CONNECT-BRACKET	4
4	600-01578-01	JP-55-FLOOR-TRIM	2
5	600-01582-01	JP-55-DIAMOND-PLATE-CENTER	1
6	606-01030-01	DECAL-FLOOR-SIDE-JP-55	2

**JURASSIC PARK-55-ENVIRONMENTAL
FLOOR BOX ASSEMBLY**

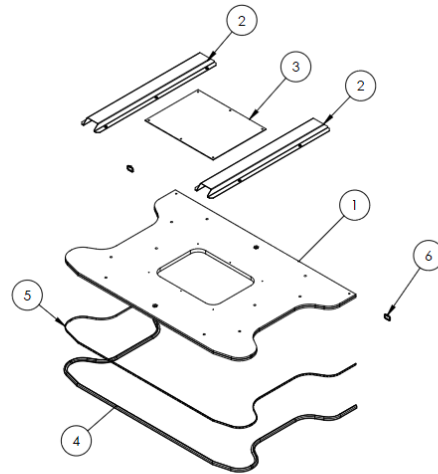

ITEM NO.	PART NUMBER	DESCRIPTION	QTY.
1	601-00711-01	JP-55-ROOF-PANEL	1
2	600-01469-01	JP-55-ROOF-BRACKET	2
3	600-01478-01	JP-55-PETG-ROOF-WINDOW	1
4	603-00718-01	3/4 LED T-MOLD (HOUSING - 114")	1
5	500-00149-01	LED-STRIP-FOR-TMOLD-ROOF-JP-55	1
6	TIE-WRAP	TIE-WRAP	2

**JURASSIC PARK-55-ENVIRONMENTAL
ROOF ASSEMBLY**

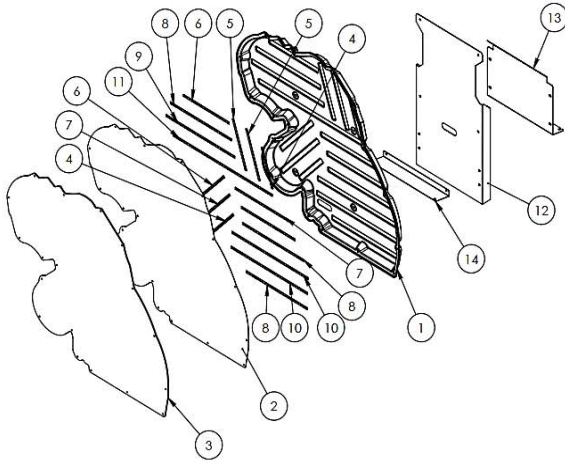

ITEM NO.	PART NUMBER	DESCRIPTION	QTY.
1	603-00760-01	JP-DINO-MARQUEE-PAN-VACFORM	1
2	606-01084-01	JP Dino Marquee Translite	1
3	600-01580-01	JP Dino Marquee PETG	1
4	500-00162-01 (20 CM)	White Flexible LED Tape, w/ FOAM	2
5	500-00162-01 (25 CM)	White Flexible LED Tape, w/ FOAM	2
6	500-00162-01 (30 CM)	White Flexible LED Tape, w/ FOAM	2
7	500-00162-01 (35 CM)	White Flexible LED Tape, w/ FOAM	3
8	500-00162-01 (40 CM)	White Flexible LED Tape, w/ FOAM	3
9	500-00162-01 (45 CM)	White Flexible LED Tape, w/ FOAM	1
10	500-00162-01 (50 CM)	White Flexible LED Tape, w/ FOAM	2
11	500-00162-01 (65 CM)	White Flexible LED Tape, w/ FOAM	1
12	600-01473-01	JP-55-STRUT-DINO-HEAD	1
13	600-01474-01	JP-55-COVER-STRUT	2
14	600-01581-01	JP-55-BRACKET-FRONT-DINO-HEAD	2

JURASSIC PARK-55-ENVIRONMENTAL
JP-DINO-MARQUEE
ASSEMBLY

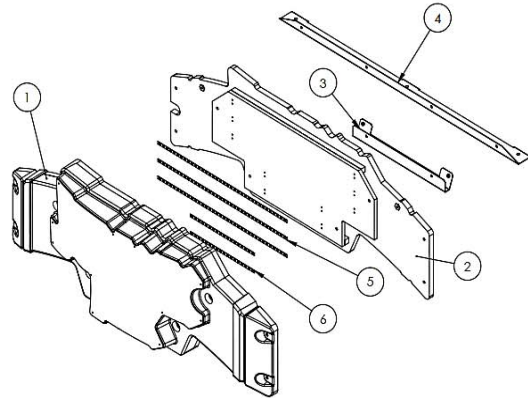

ITEM NO.	PART NUMBER	DESCRIPTION	QTY.
1	603-00749-0	603-00749-01-DISTORTION-ASSY	1
2	601-00718-01	JP-GATE-LOGO-VACFORM-PANEL	1
3	600-01472-01	JP-55-SEATCAB-VACFORM-BRACKET	1
4	600-01579-01	JP-55-BRACKET-GATE-LOGO	1
5	60CM-WHITE-LED-STRIP	60CM-WHITE-LED-STRIP	3
6	30CM-WHITE-LED-STRIP	30CM-WHITE-LED-STRIP	2

JURASSIC PARK-55-ENVIRONMENTAL
JP-LOGO-VACFORM
ASSEMBLY



Operator's Manual

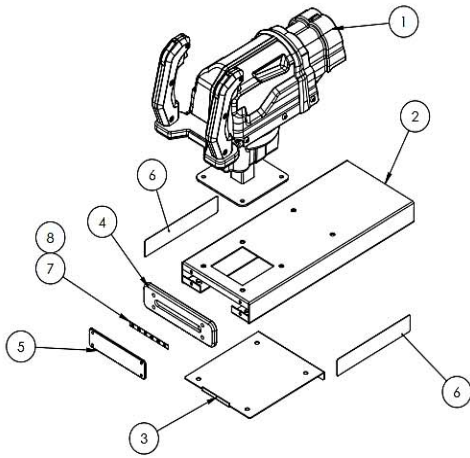

ITEM NO.	PART NUMBER	DESCRIPTION	QTY.
1	604-00039-01	JP-GUN-ASSY	1
2	600-01459-01	JP-55-GUN-MOUNT-BRACKET	1
3	600-01460-01	JP-55-GUN-MOUNT-COVER	1
4	600-01479-01	JP-55-GUN-BASE-CAP	1
5	600-01480-01	JP-55-POLYCARB-GUN-BASE	1
6	606-01042-01	DECAL-GUN-MOUNT-BASE-JP-55	2
7	10cm LED Strip (RED)	10cm LED Strip (RED)	1
8	10cm LED Strip (BLUE)	10cm LED Strip (BLUE)	1

LEFT-GUN-ASSY-ONLY

RIGHT-GUN-ASSY-ONLY

JURASSIC PARK-55-ENVIRONMENTAL
GUN-MOUNT-ASSEMBLY

ITEM NO.	PART NUMBER	DESCRIPTION	QTY.
1	1_550_Imperial_assy_asm	55" KORTEK LCD ASSY	1
2	600-01206-01	BRACKET-FRAME-HORIZ-55LCD-ALIENS	2
3	600-01205-01	BRACKET-FRAME-VERT-55LCD-ALIENS	2
4	600-01137-01	BRACKET-MOUNT-55LCD-OPEN-FRAME	4
5	600-01138-01	GLASS-SHIELD-55LCD	1
6	600-01482-01	JP-55-STRUT-LCD	2
7	foamtape-horz	.25 X .50 X 47.74LG FOAM TAPE	2
8	foamtape-vert	.25 X .50 X 29.00LG FOAM TAPE	2

JURASSIC PARK-55-ENVIRONMENTAL
55"LCD-ASSEMBLY

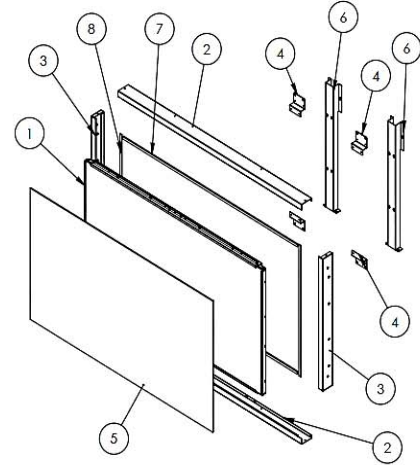

Operator's Manual

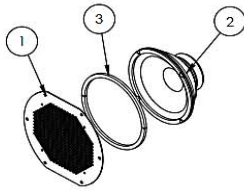

ITEM NO.	PART NUMBER	DESCRIPTION	QTY.
1	600-01526-01	GRILL-WOOFER-JP-55	1
2	2-1-18-00-00-000	8" WOOFER, 4 Ohm, POLY-MICA CONE	1
3	FOAM INSULATION	FOAM INSULATION	2

JURASSIC PARK-55-ENVIRONMENTAL WOOFER ASSEMBLY

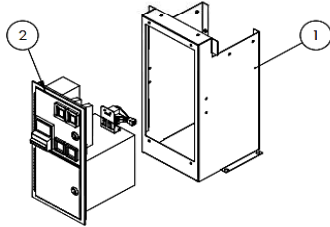

ITEM NO.	PART NUMBER	DESCRIPTION	QTY.
1	600-01456-01	JP-55-COIN-VAULT	1
2	800-00005-01	MID-WIDTH COINDOOR - BBHD	1

JURASSIC PARK-55-ENVIRONMENTAL COIN-VAULT-ASSEMBLY

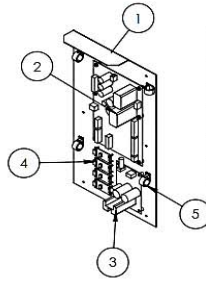

ITEM NO.	PART NUMBER	DESCRIPTION	QTY.
1	600-01583-01	RIO-PLATE-SUB-WOOFER-GUN-PCB	1
2	500-00040-01	RIO-board	1
3	SUB-WOOFER-BOARD	SUBWOOFER-PCB-ASSY	1
4	GUN-SOLENOID-PCB	GUN-SOLENOID-PCB	4
5	Cable Clamp_750	Cable Clamp 3/4", Screw Mount	4

JURASSIC PARK-55-ENVIRONMENTAL RIO-PLATE-ASSEMBLY

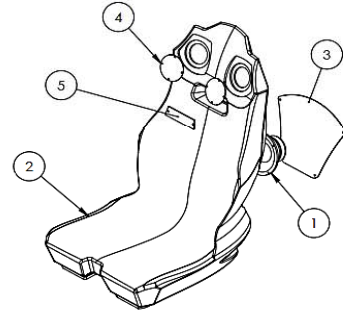

ITEM NO.	PART NUMBER	DESCRIPTION	QTY.
1	2-1-11-00-00-000	SPEAKER-WOOFER-6.5" 4 OHm	1
2	603-00523-01	DD-PLASTIC-SEAT-RED	1
3	600-00106-01	WOOFER-GRILL	1
4	600-00105-01	SEAT-HEADREST-SPEKER-GRILL	2
5	600-00109-01	SEAT-BACK-PLATE-LOW	1

JURASSIC PARK-55-ENVIRONMENTAL SEAT ASSEMBLY

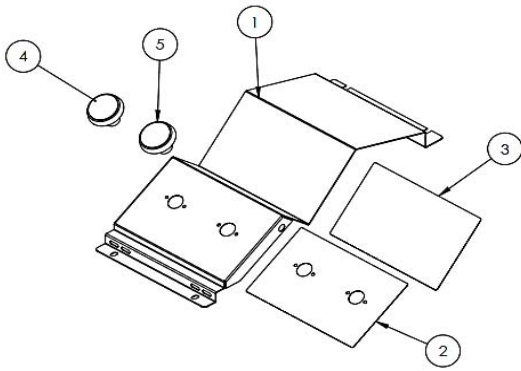

ITEM NO.	PART NUMBER	DESCRIPTION	QTY.
1	600-01462-01	JP-55-CONTROL-PANEL	1
2	606-01038-01	DECAL-CONTROL-PANEL-BUTTON-JP-55	1
3	606-01039-01	DECAL-CONTROL-PANEL-JP-55	1
4	702-00060-00	LARGE RND - RED - PLAYER -1 BUTTON	1
5	702-00061-00	LARGE RND - BLUE - PLAYER -2 BUTTON	1

JURASSIC PARK-55-ENVIRONMENTAL
CONTROL-PANEL-ASSEMBLY

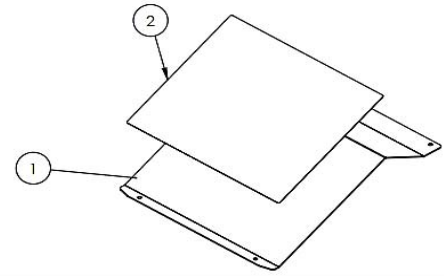

ITEM NO.	PART NUMBER	DESCRIPTION	QTY.
1	600-01463-01	JP-55-CP-DECAL-BRACKET	1
2	606-01040-01	DECAL-PLAYER-1-JP-55	1

JURASSIC PARK-55-ENVIRONMENTAL
PLAYER-1-DECAL-ASSEMBLY

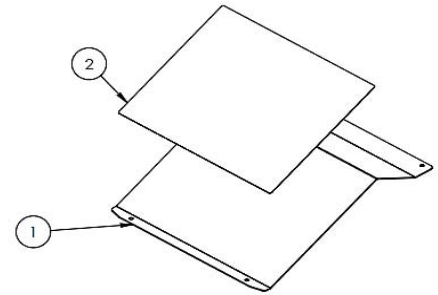

ITEM NO.	PART NUMBER	DESCRIPTION	QTY.
1	600-01463-01	JP-55-CP-DECAL-BRACKET	1
2	606-01041-01	DECAL-PLAYER-2-JP-55	1

JURASSIC PARK-55-ENVIRONMENTAL
PLAYER-2-DECAL-ASSEMBLY

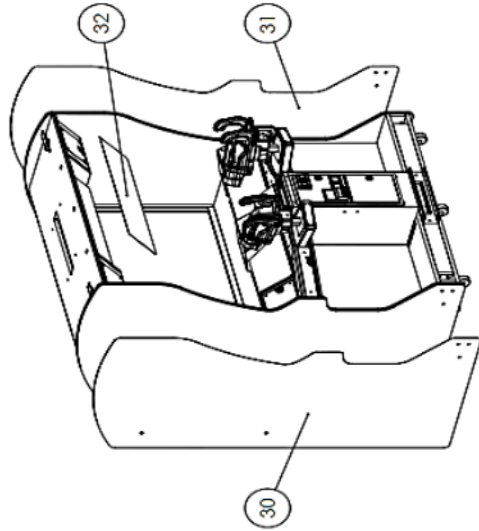

ITEM NO.	PART NUMBER	DESCRIPTION	QTY.
1	601-00702-01	JP-55-WOOD-MAIN-CABINET	1
2	601-00705-01	JP-55-MAIN-CAB-DOOR-ASSY	1
3	601-00706-01	JP-55-MAIN-CAB-LCD-DOOR-ASSY	1
4	JP-55-LCD-ASSY	ASSY-55-LCD-ALENS	1
5	JP-55-COIN-VAULT-ASSY	JP-55-COIN-VAULT-ASSY	1
6	GUNMOUNT-LEFT-ASSY	GUNMOUNT-ASSY	1
7	GUNMOUNT-RIGHT-ASSY	GUNMOUNT-ASSY	1
8	JP-55-CP-CENTER-ASSY	JP-55-CP-CENTER-ASSY	1
9	PLAYER-1-DECAL-ASSY	PLAYER-1-DECAL-ASSY	1
10	PLAYER-2-DECAL-ASSY	PLAYER-2-DECAL-ASSY	1
11	DINO_TOPPER-ASSY	DINO-TOPPER-ASSY	1
12	600-00905-01_600-00906-01	1"WD NYLON STRAP & 1"BUCKLE CLASP	2
13	RIO-HARDWARE-ASSY	RIO-HARDWARE-ASSY	1
14	500-00166-01	MEANWELL-150W-12V-DUAL-VOLT-PS	2
15	500-00187-01	MEANWELL-150W-24V-6.5A-DUAL-VOLT-PS	1
16	2-1-10-00-00-000	5.25 FULL RANGE SPEAKER	4
17	2-1-02-00-00-017	APS Power Supply (Bracket #90-AP188)	1
18	HP6005	HP 6005 PC ASSY	1
19	600-01458-01	JP-55-CTR-CONNECT-BRACKET	1
20	600-01461-01	JP-55-CONTROL-BASE-BRACKET	2
21	600-01464-01	JP-55-SPEAKER-GRILL	4
22	600-01465-01	JP-CP-VENT-GRILL	2
23	600-01470-01	JP-55-CABLE-COVER	2
24	603-00718-01	3/4"LED T-MOLD (HOUSING ONLY - 27.13")	2
25	500-00131-01	65CM-LED-STRIP-FOR-TMOLD-CP-JP-55	2
26	600-00891-01	Securing Nylon Strap Plate	1
27	FOAM-PC-5X8X14.5	FOAM-PC-5X8X14.5 - POLYETHYLENE PLANK	1
28	800-00001-00	120mm Wire Fan Guard	3
29	820-00001-00	FAN, 120VAC, 19/15W	3
30	606-01025-01	DECAL-LEFT-MAIN-CAB-JP-55	1
31	606-01026-01	DECAL-RIGHT-MAIN-CAB-JP-55	1
32	606-01027-01	DECAL-MAIN-CAB-CENTER-JP-55	1

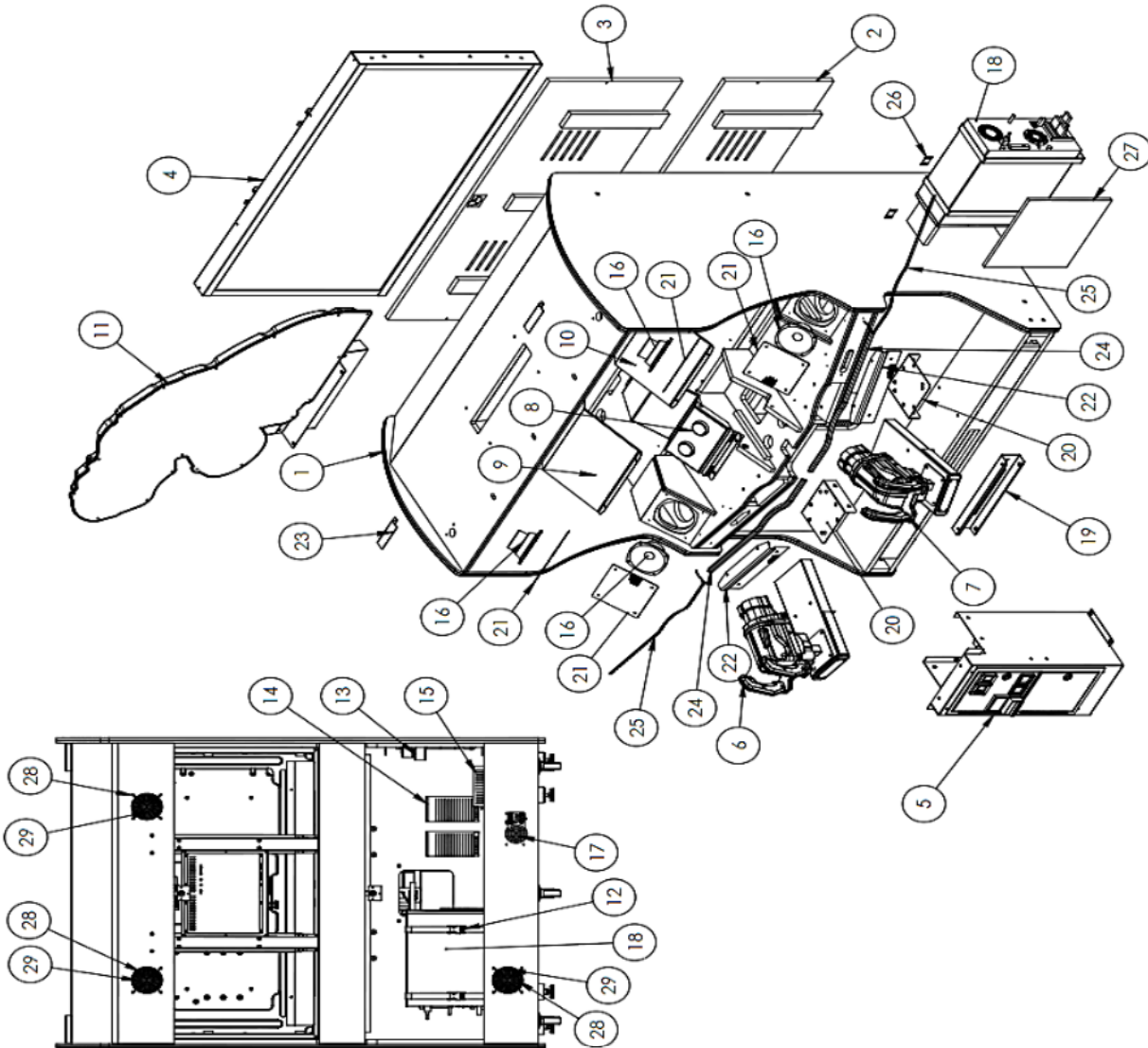

**JURASSIC PARK-55-ENVIRONMENTAL
MAIN CAB ASSEMBLY**



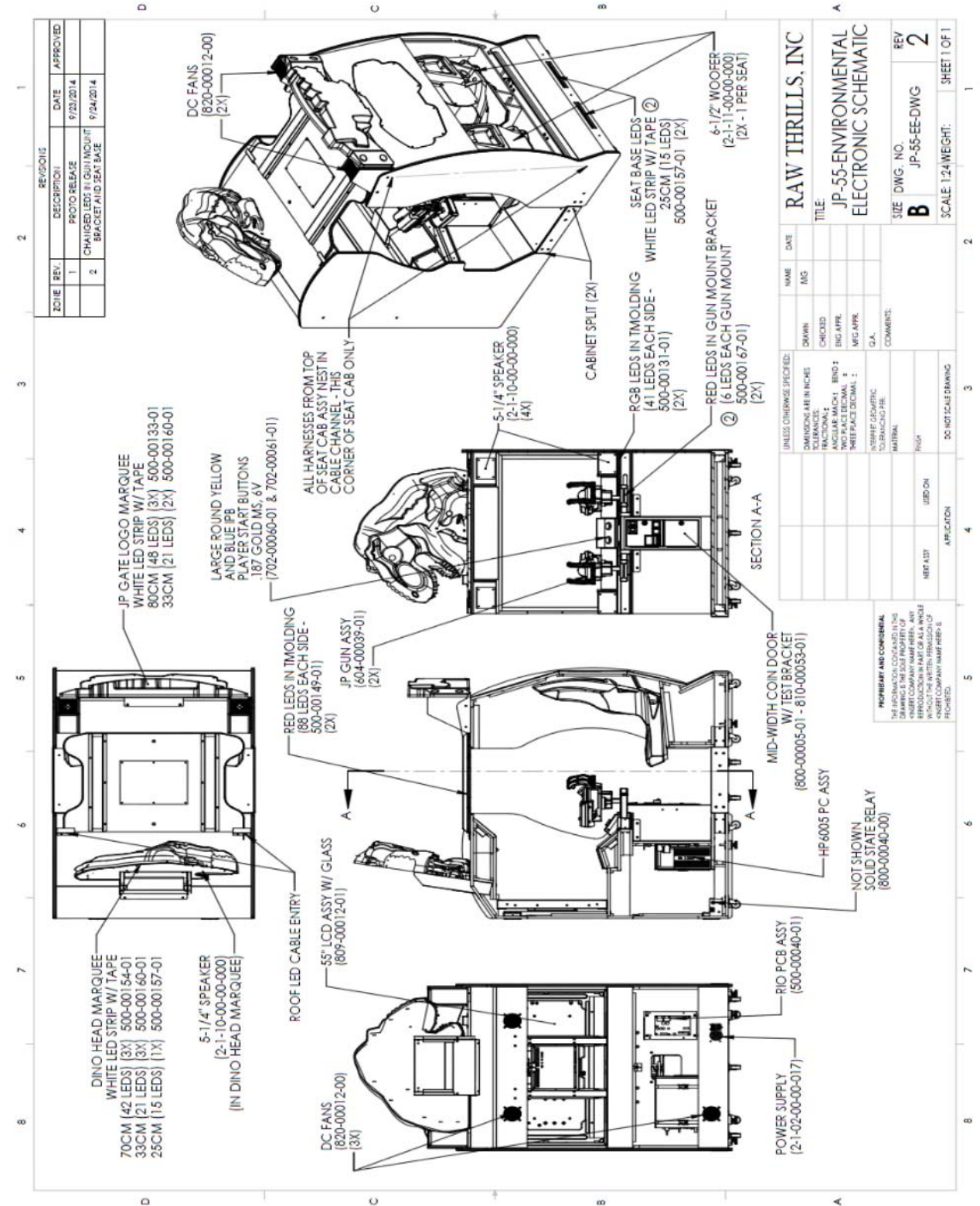

Operator's Manual

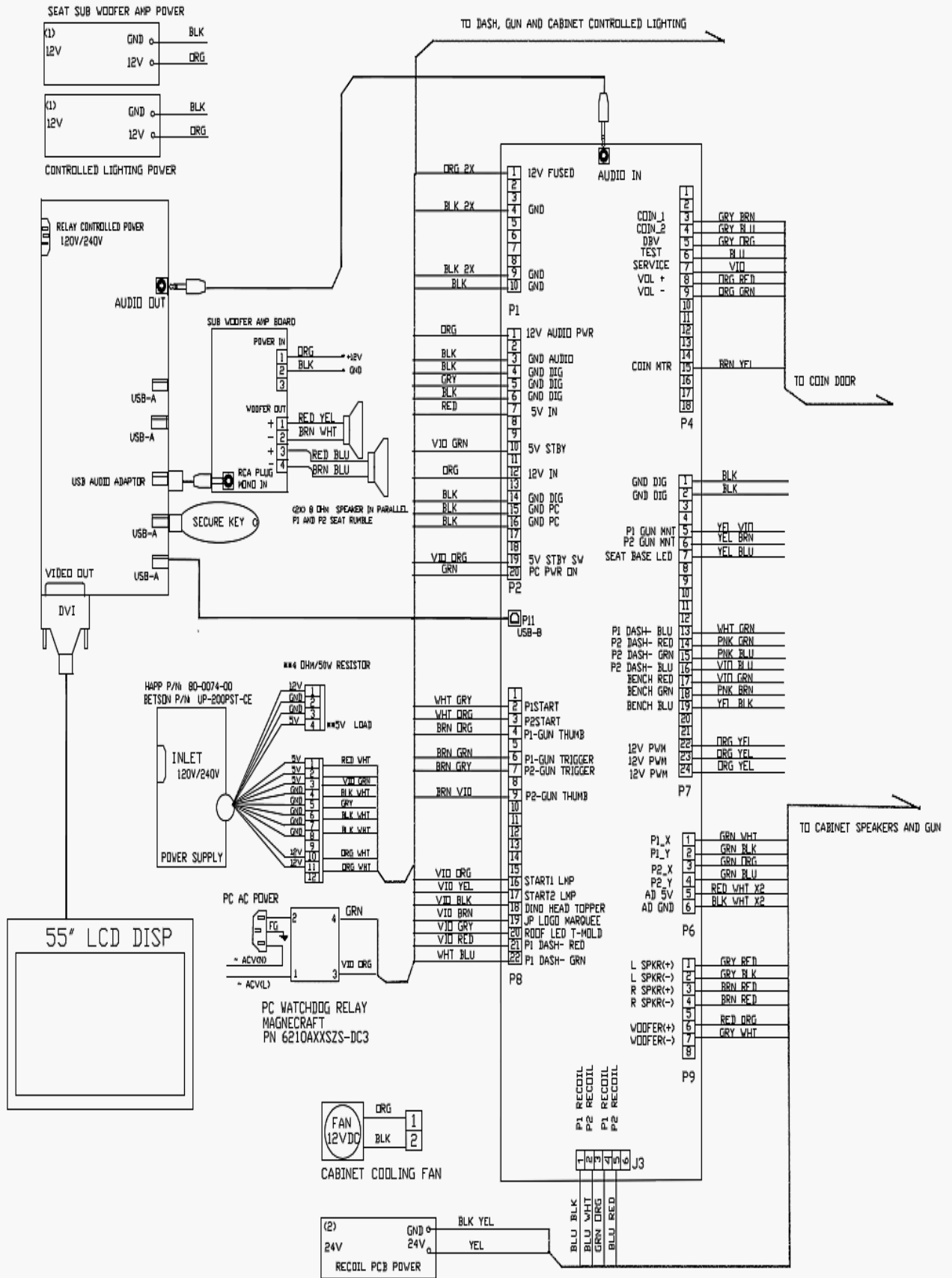

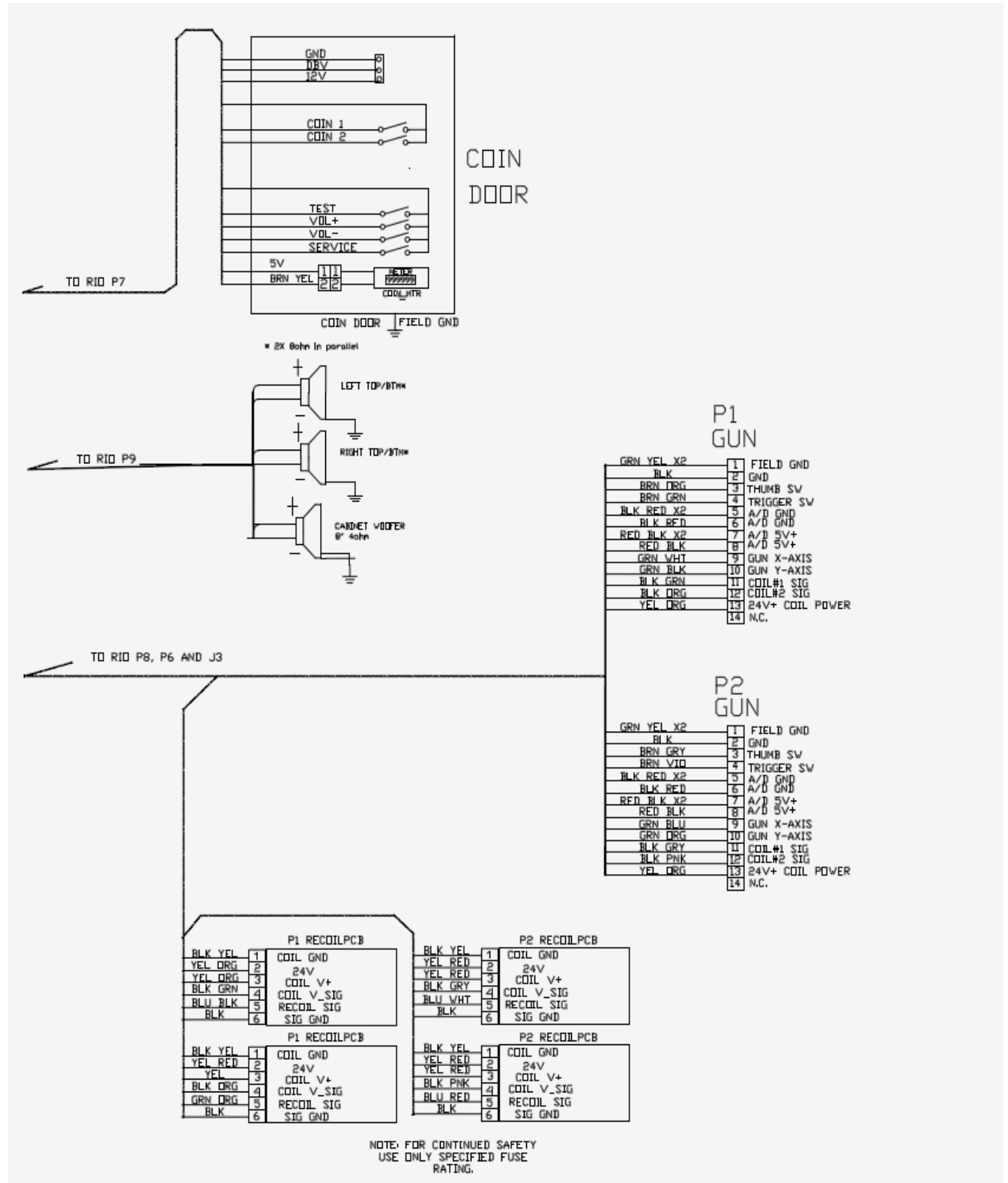

NOTES:

