



OPERATOR'S MANUAL

- Failure to properly operate this machine could result in malfunction or accident, so please read this manual carefully before commencing operation. Be sure to operate the machine as described in this manual.
- Keep this manual available and ready for use when necessary.
- If the machine fails to function correctly, immediately turn off the machine and contact your local distributor. (60 Day Warranty, from date of purchase)

October 22, 2010

For Parts or Service contact your local Distributor or:

**Betson Enterprises
303 Paterson Plank Road
Carlstadt, New Jersey**



**Main Phone: (201) 438-1300
Toll Free Phone: (800) 524-2343
Part Phone: (800) 828-2048**

CAUTION:

- The specifications of this product are subject to change without notice for reasons such as performance.
- The content of this game, its main devices and design are protected under each federal law concerning patent, copyright and other intellectual properties.
- Unauthorized reproduction of this document or any of its contents is strictly forbidden.

Safety Instructions

Safety instructions apply to operators and service personnel. Read these instructions before preparing the video game machine for play. Other safety instructions appear throughout this manual.

WARNING: TRANSPORTING THE VIDEO GAME MACHINE (VGM).

The VGM contains glass and fragile electronic devices. Use appropriate care when transporting. Avoid rough handling when moving the VGM.

WARNING: DISCONNECT POWER.

Always turn the power OFF and unplug the VGM before attempting service or adjustments unless otherwise instructed. Installing or repairing components with the power switched ON can damage the components and void warranty.

WARNING: GROUND GAMES.

Avoid electrical shock! Do not plug in the VGM until you have inspected and properly grounded it. Only plug into a grounded, three-wire outlet. Do not use a "cheater" plug, or cut off the ground pin on the line cord.

WARNING: AVOID ELECTRICAL SHOCKS.

This VGM does not utilize an isolation transformer. Internal cabinet AC is not isolated from the external AC line.

WARNING: HANDLE FLOURESCENT TUBE AND CRT WITH CARE.

If you drop a fluorescent tube or CRT and it breaks, it will implode! Shattered glass can fly eight feet or more from the implosion.

WARNING: CHECK POWER SELECTOR, LAMP.

Set the 115/230 VAC selector switch on the power supply for the correct line voltage on the installation site. Verify that the fluorescent lamps are rated for the proper line voltage.

WARNING: USE PROPER FUSE.

Avoid electrical shock! Replacement fuses must be identically rated to the original fuse!

WARNING: ATTACH CONNECTORS PROPERLY.

Be sure all connectors mate properly. If connectors do not slip in easily, do not force them. Connectors are often keyed and only connect one way. Check for correct orientation.

WARNING: USE EXTREME CARE WHEN HANDLING PC.

The PC contains sensitive components such as a hard drive. Do not handle roughly. Call your distributor before servicing PC internal components. Ask about warranty information as it relates to the PC.

WARNING: HAZARD TO EPILEPTICS.

A very small portion of the population has a condition, which may cause them to experience epileptic seizures or have momentary loss of consciousness when viewing certain kinds of flashing lights or patterns that are present in our daily environment. These persons may experience seizures while watching some kinds of television pictures or playing certain video games. Peoples who have not had any previous seizures may nonetheless have an undetected epileptic condition.

If you or anyone in your family has experienced symptoms linked to an epileptic condition (e.g., seizures or loss of awareness), immediately consult your physician before using any video games.

We recommend that parents observe their children while they play video games. If you or your child experience the following symptoms: dizziness, altered vision, eye or muscle twitching, involuntary movements, loss of awareness, disorientation, or convulsions, DISCONTINUE USE IMMEDIATELY and consult your physician.



Setup and Operation

Product Specifications:

OPERATING REQUIREMENTS

ELECTRICAL POWER

Domestic 120VAC @ 60 Hz, 5 amps

Foreign 240VAC @ 50Hz, 3 amps

TEMPERATURE

32° F to 100°F

(0°C to 38°C)

HUMIDITY

Not to exceed 95% relative humidity.

INSPECTION AND INSTALLATION

WARNING: Use extreme care when moving or servicing the game cabinet. Don't plug in the game until you have read this manual.

Please check the following after the game after the game has been removed from its shipping crate and placed in a suitable play or service area.

Make sure that the game cabinet is level. Adjust the casters as needed.

1. Check the AC line cord for any visible signs of damage to the plug or line cord insulation.
2. Check for possible shipping damage to the following:
 - Player interfaces: seat, handlebars, buttons, keypad and brake and shift levers.
 - Seat assembly.
 - Monitor glass.
 - Cabinet backdoor.
 - Cabinet coin door.
 - Cabinet and seat decals.
3. Remove the coin door key from the coin return chute.
4. Open the top coin door and locate the key for the backdoor and the cashbox.
5. Locate hardware kit. Included are: tamper proof tool kit, crossover network cable, line cord and seat hardware fasteners (8 sets)
6. Remove the backdoor the backdoor from the cabinet and visually inspect the electronic components.
7. Verify that all connectors are secure and that the bottom of the cabinet is free of loose objects, which may have possibly come loose during shipping.

Seat Assembly Procedure

WARNING: The cabinet is top heavy. Install only on level surface. Use the leg levelers to make sure the cabinet and seat are stable. Do not push against plastic parts during movement. Raise the shipping screws all the way up before game can be played.

1. Roll the cabinet and seat to the intended installation location. Make sure setup up area is suitable for your game operation. Allow for at least 3 – 4 feet of clearance from the bike for player and public traffic convenience and safety during game play. Allow for enough clearance from the backdoor for proper airflow. Do not block the air intake or exhaust vents located in the back of the game.

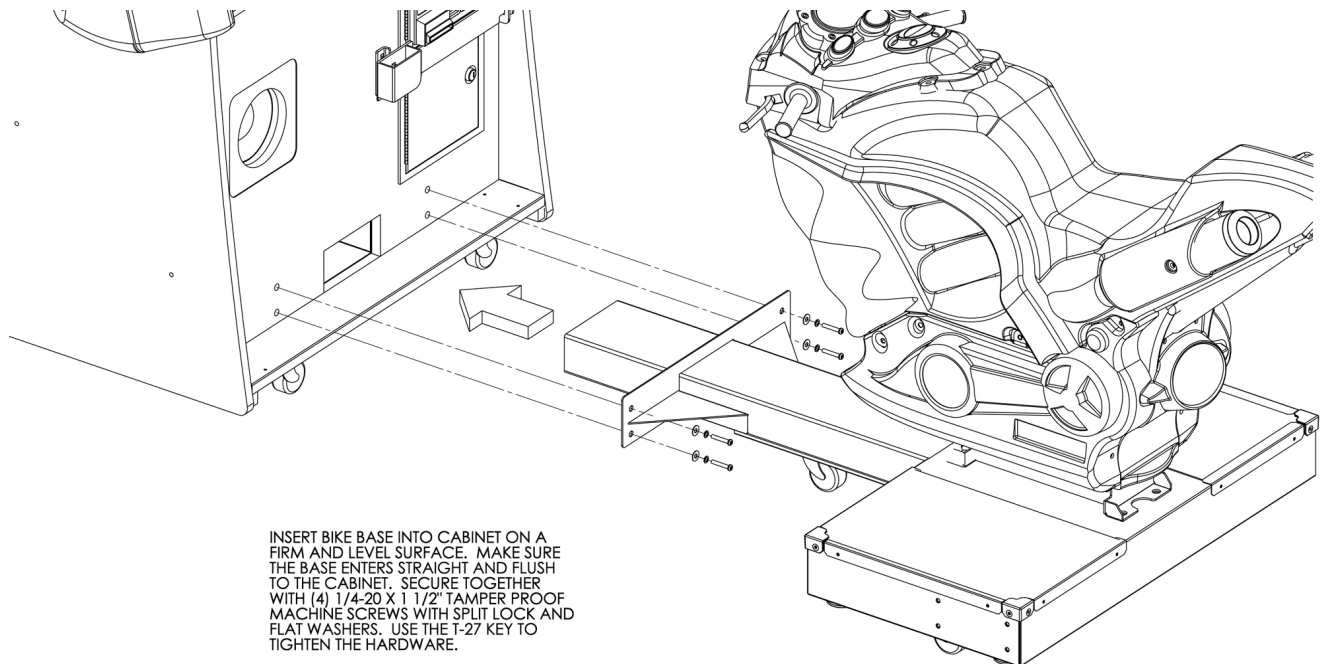

2. Position the seat base assembly so that it is aligned with the mounting holes in the lower main cabinet housing the monitor. Push the seat assembly forward to meet the mounting holes and find the four 1/4 -20 x 2" bolts and large flat washers provided in the hardware bag inside the cashbox. Make all necessary cable connections and ensure no wires are pinched during the attachment process.
3. Adjust all levelers until both cabinet and seat are flush and parallel with each other.
4. Tighten the screws firmly using a T-27 Torx tool.
5. Raise the shipping screws located under the bike assembly. One is located on each underside of the bike. This keeps the bike stable during transport or service. Raise both shipping screws all the way up without removing it completely out. This ensures safe keeping for future use.

Power Up Procedure

1. Plug the game line cord into an appropriately wired and fused AC receptacle.
2. Locate the game AC main switch to the bottom left side on back of the game cabinet.
3. Turn the switch to the ON position.
4. The game attract feature will begin after the game is finished loading- approximately 1 minute.
5. Proceed to Switch Test of this document and verify proper game operation.

Game Networking

NOTICE: To link the two games together, use the crossover cable provided in the spare parts bag. Use of another cable other than the one shipped with the game could void warranty or cause games not to link. Use network cables, which are at least CAT5 grade.

Networking Considerations

Each FNFSB game ships with a cross over cable for linking 2 games. Optionally, a hub and network patch cords can be installed to link 3 or more games.

Take care to protect exposed game wiring from general foot traffic around the game. Use a conduit or wire way to protect the cables as needed.

Please mark linking cables for your game if other such cables are in the vicinity to avoid confusion. Network cables are not marked or coded.

Avoid routing the network cables near sources of heat, moisture or electrical energy such as neon lights, compressor motors, transformers etc.

Networking Setup 2 Games

1. Remove the cross over network cable from the parts bag located inside the cashbox.
2. If you are linking two games connect each end of the cable to the network jack behind each PC.
3. Neatly route the cable through the notch on the back of the cabinet.
4. Turn on networking setting by entering the Test Menu > System Adjustment>Network Enabled= Yes.
5. Set the Current Machine ID by giving each machine a unique number.
6. Reset all games simultaneously and verify that link is successful.

Networking Setup 3 - 8 Games

1. Prepare network hub with enough ports and correct number of patch cables to support the number of games that you plan to link. Network hub and cables are not shipped with the games and are sold separately.
2. Connect each end of the cable to the network jack behind each PC.
3. Connect each of the opposite ends of the cables to the network hub. Please refer to the network hub manual for other networking considerations specific to your hub.
4. Setup the networking parameters on each machine by performing Step 4 and Step 5 above.

Adjustments, Audits & Diagnostics

Locate the *Service Button Panel*. It is mounted inside the coin door area on top of the cash box vault. Press the **TEST** button to access the **Test Menu**.

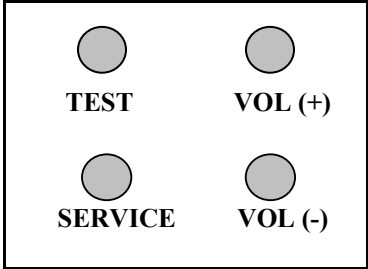

Menu Navigation:

Button	Action
Test	Enter Operator Screen
Start Button	Enter/Select Item Sub-Menu
Vol. (+) or View Button	Scroll up thru Menu items
Vol. (-) or Tunes Button	Scroll down thru Menu items
Service or Shift Lever	Exit to previous Menu

MAIN MENU

The **Test Main Menu** appears when the **TEST** button is pressed.

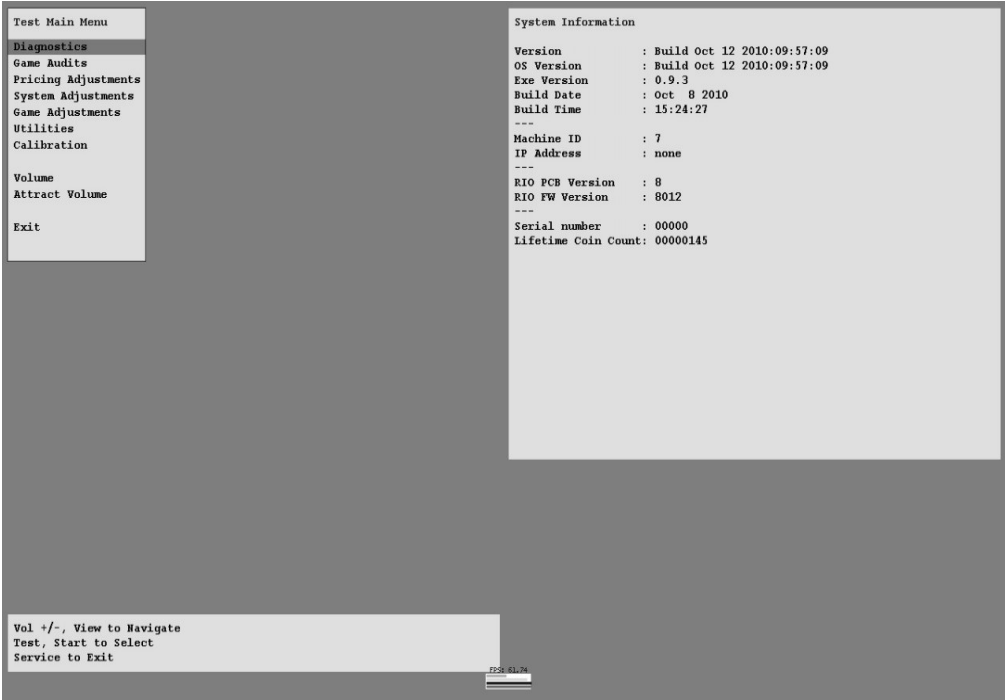

Diagnostics Menu System

From the **Main Menu**, select **Diagnostics** and enter to view options.

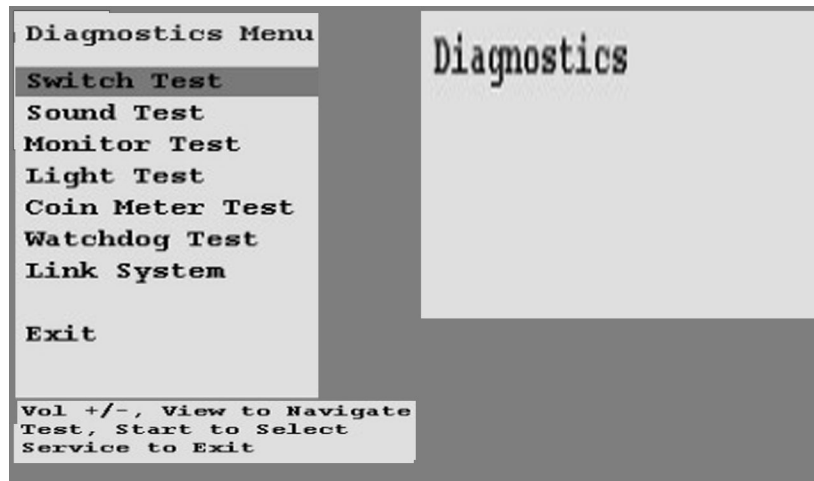

Switch Test

From the **Diagnostics** select and enter **Switch Test**. Verify proper switch input function using this menu. Each switch activated will be indicated on the test screen in corresponding yellow box and will be accompanied by a switch active sound indicator. Verify pot value for min, center and max are correct. If not, proceed to Calibration section of this manual. Press and hold the **Service Button** for three seconds to return to the **Diagnostics Menu**.



Sound Test

From the **Diagnostics Menu** select and enter **Sound Test**. Verify that marquee, cabinet and seat sound volume and quality are good. Press the Service Button to return to **Diagnostics Menu**

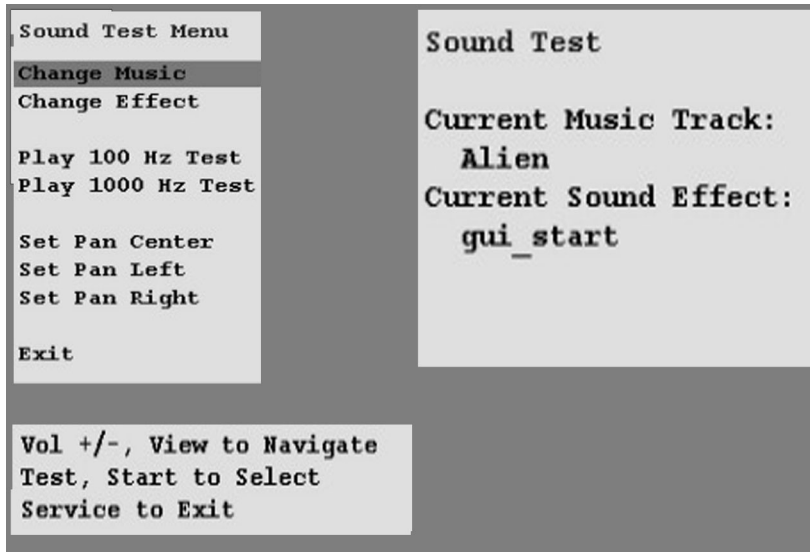

Lamp Test

From the **Diagnostics Menu** select and enter **Lamp Test**. Use View1 or View 3 to select the lamp and press Start to activate that lamp. Verify that ALL lamps are working.

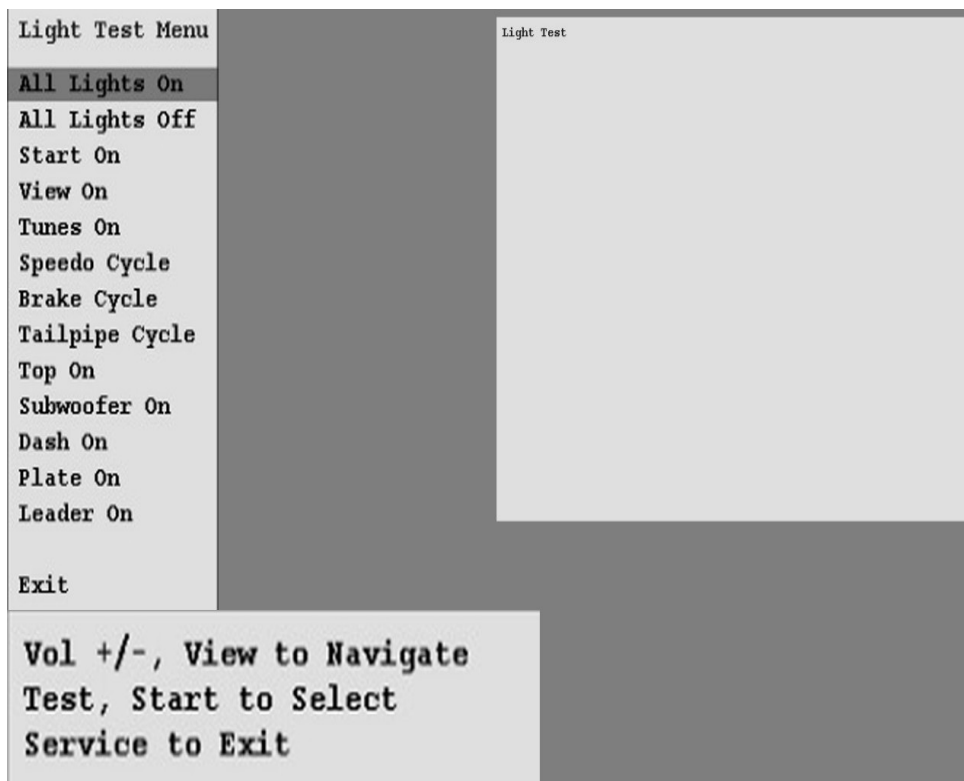

Note:

Lamp function could also be verified using Switch Test.

Please check the coin door lamps as part of your game diagnostic check.

Coin Meter Test

From the ***Diagnostics Menu*** select and enter ***Coin Meter Test***. Advance the meter once using by pressing Start. Press the Service Button to return to ***Diagnostics Menu***.

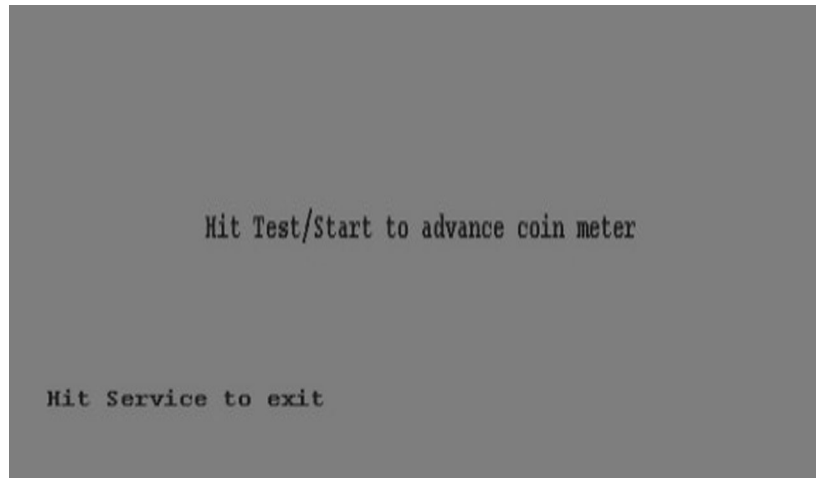

Watchdog Test

From the ***Diagnostics Menu*** select and enter ***Watchdog Test***. The game will reset in approximately 6 seconds. The watchdog feature allows the PC to monitor normal game software and hardware operation.

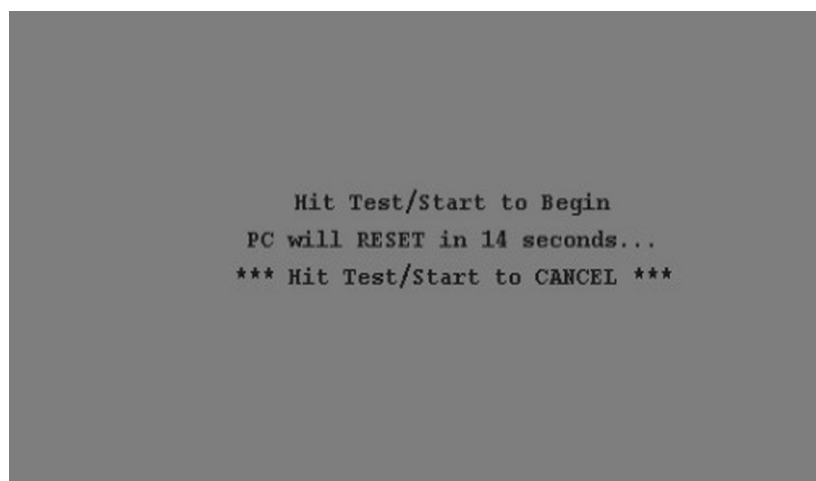

Link System

From the *Diagnostics Menu* select and enter **Link System Test**. Verify link status and reliability using the items on the menu below.

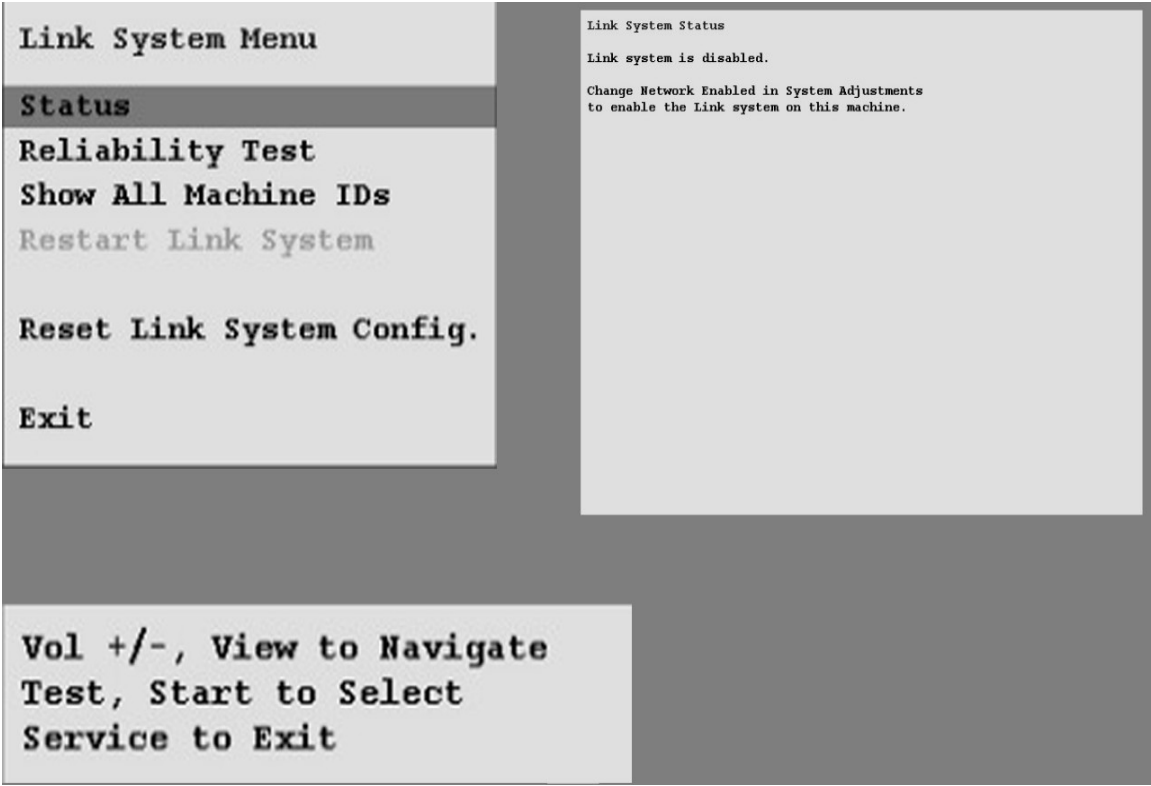

Game Audits

From the *Main Menu*, select **Game Audits** and enter to view options.

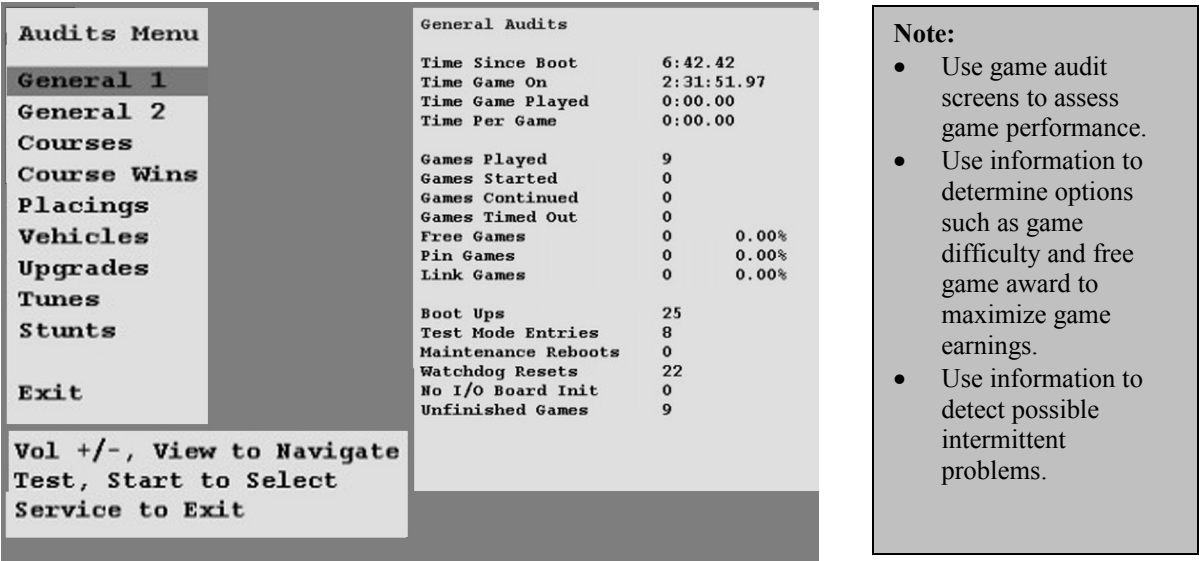

General 1 Audits

From the *Audits Menu*, select **General 1** and enter to view general game statistics. Press the Service Button to return to *Main Menu*.

Audits Menu	General Audits
General 1	Time Since Boot 6:42.42
General 2	Time Game On 2:31:51.97
Courses	Time Game Played 0:00.00
Course Wins	Time Per Game 0:00.00
Placings	Games Played 9
Vehicles	Games Started 0
Upgrades	Games Continued 0
Tunes	Games Timed Out 0
Stunts	Free Games 0 0.00%
Exit	Pin Games 0 0.00%
	Link Games 0 0.00%
	Boot Ups 25
	Test Mode Entries 8
	Maintenance Reboots 0
	Watchdog Resets 22
	No I/O Board Init 0
	Unfinished Games 9
Vol +/-, View to Navigate	
Test, Start to Select	
Service to Exit	

General 2 Audits

From the *Audits Menu*, select **General 2** and enter to view additional general game statistics. Press the Service Button to return to *Main Menu*.

Audits Menu	General Audits
General 1	Automatic Games 0 0.00%
General 2	Manual Games 0 0.00%
Courses	Low Cam Time 0:00.00
Course Wins	Med Cam Time 0:00.00
Placings	High Cam Time 0:00.00
Vehicles	Total Coindrops 114
Upgrades	Slot 0 Left 114
Tunes	Slot 1 Right 0
Stunts	Slot 2 DBV 0
Exit	Current Credits 19
	Current Coins 2
	Lifetime Coin Count 00000095
Vol +/-, View to Navigate	
Test, Start to Select	
Service to Exit	

Course Audits

From the **Audits Menu**, select **Courses** and enter to view individual information on each course. View how many times each course is selected, as well as its popularity by overall percentage. Press the Service Button to return to **Main Menu**.

Audits Menu	Track	Count	Percent
General 1	SB2: Space Race 1	0	0.00%
General 2	SB2: Paris	0	0.00%
Courses	SB2: Moab	0	0.00%
Course Wins	SB2: Spain	0	0.00%
Placings	SB2: Thailand	0	0.00%
Vehicles	SB2: Yosemite	0	0.00%
Upgrades	SB2: Africa	0	0.00%
Tunes	SB2: Dubai	0	0.00%
Stunts	SB2: Himalayas	0	0.00%
Exit	SB2: Las Vegas	0	0.00%
	SB2: Space Race 2	0	0.00%
	SB1: Chicago	0	0.00%
	SB1: Switzerland	0	0.00%
	SB1: Florida	0	0.00%
	SB1: Hawaii	0	0.00%
	SB1: Detroit	0	0.00%
	SB1: Monaco	0	0.00%
	SB1: Shanghai	0	0.00%
	SB1: Sturgis	0	0.00%

Vol +/-, View to Navigate
Test, Start to Select
Service to Exit

Course Wins Audit

From the **Audits Menu**, select **Courses Wins** and enter to view individual win and overall percentage information on each course. Press the Service Button to return to **Main Menu**.

Audits Menu	Track	Wins	Percent
General 1	SB2: Space Race 1	0	0.00%
General 2	SB2: Paris	0	0.00%
Courses	SB2: Moab	0	0.00%
Course Wins	SB2: Spain	0	0.00%
Placings	SB2: Thailand	0	0.00%
Vehicles	SB2: Yosemite	0	0.00%
Upgrades	SB2: Africa	0	0.00%
Tunes	SB2: Dubai	0	0.00%
Stunts	SB2: Himalayas	0	0.00%
Exit	SB2: Las Vegas	0	0.00%
	SB2: Space Race 2	0	0.00%
	SB1: Chicago	0	0.00%
	SB1: Switzerland	0	0.00%
	SB1: Florida	0	0.00%
	SB1: Hawaii	0	0.00%
	SB1: Detroit	0	0.00%
	SB1: Monaco	0	0.00%
	SB1: Shanghai	0	0.00%
	SB1: Sturgis	0	0.00%

Vol +/-, View to Navigate
Test, Start to Select
Service to Exit

Placings Audit

From the **Audits Menu**, select **Placing** and enter to view individual count for each standing and percentage information. Use this information to determine game difficulty adjustments to properly reward players and maximize game earning performance. Press the Service Button to return to **Main Menu**.

Audits Menu	Placings / Percent
General 1	1st Place 0 0.00%
General 2	2nd Place 0 0.00%
Courses	3rd Place 0 0.00%
Course Wins	4th Place 0 0.00%
Placings	5th Place 0 0.00%
Vehicles	6th Place 0 0.00%
Upgrades	7th Place 0 0.00%
Tunes	8th Place 0 0.00%
Stunts	9th Place 0 0.00%
Exit	10th Place 0 0.00%
	11th Place 0 0.00%
	12th Place 0 0.00%
	Average Place 0.00
	Max Win Streak 0
	Max Lose Streak 0
	Cur Win Streak 0
	Cur Lose Streak 0
Vol +/-, View to Navigate Test, Start to Select Service to Exit	

Vehicles Audit

From the **Audits Menu**, select **Vehicles** and enter to view individual count for each vehicle selection and percentage information. Press the Service Button to return to **Main Menu**.

Audits Menu	Vehicle Selects / Percent
General 1	KX-450 0 0.00%
General 2	Vulcan 0 0.00%
Courses	Ninja ZX-14 0 0.00%
Course Wins	Yamaha Warrior 0 0.00%
Placings	Yamaha R1 0 0.00%
Vehicles	Yamaha VMax 0 0.00%
Upgrades	Ducati 1198s 0 0.00%
Tunes	Ducati Monster 0 0.00%
Stunts	Ducati Streetfighter 0 0.00%
Exit	T414 0 0.00%
	Chopper 0 0.00%
	X8 Lightbike 0 0.00%
Vol +/-, View to Navigate Test, Start to Select Service to Exit	

Upgrade Audit

From the **Audits Menu**, select **Upgrade Audit** and enter to individual count for each vehicle feature upgrade selection and percentage information. Press the Service Button to return to **Main Menu**.

Audits Menu	Upgrades
General 1	Decal 0
General 2	Tires 0
Courses	Neon 0
Course Wins	Nitro 0
Placings	Body 0
Vehicles	Spoiler 0
Upgrades	Engine 0
Tunes	Upgrade Users 4
Stunts	Upgrade Buy-Ins 0
Exit	Upgrade Credits 0
	1 visit: 2 50.00%
	2 - 4 visits: 1 25.00%
	5 - 9 visits: 1 25.00%
	10 - 14 visits: 0 0.00%
	15 - 19 visits: 0 0.00%
	20 - 24 visits: 0 0.00%
	25 - 29 visits: 0 0.00%
	30 - 39 visits: 0 0.00%
	40 - 49 visits: 0 0.00%
	50 - 69 visits: 0 0.00%
	70 - 99 visits: 0 0.00%
	100+ visits: 0 0.00%
Vol +/-, View to Navigate	
Test, Start to Select	
Service to Exit	

Tunes Audit

From the **Audits Menu**, select **Tunes** and enter to view individual count for each tune selected and playtime information. Use Service to Exit to main menu.

Audits Menu	Tunes (Time in Each)
General 1	Alien 0:00.00
General 2	Baja 0:00.00
Courses	Dubai 0:00.00
Course Wins	Arabia 0:00.00
Placings	Euro 0:00.00
Vehicles	Heavy 0:00.00
Upgrades	Metal 0:00.00
Tunes	Merengue 0:00.00
Stunts	Moab 0:00.00
Exit	Paris 0:00.00
	Spain 0:00.00
	Thailand 0:00.00
	Yosemite 0:00.00
	Yellowstone 0:00.00
Vol +/-, View to Navigate	
Test, Start to Select	
Service to Exit	

Stunts Audit

From the **Audits Menu**, select **Stunts** and enter to view individual count for each stunt performed. Use Shift lever or press Service to Exit to return to **Main Menu**

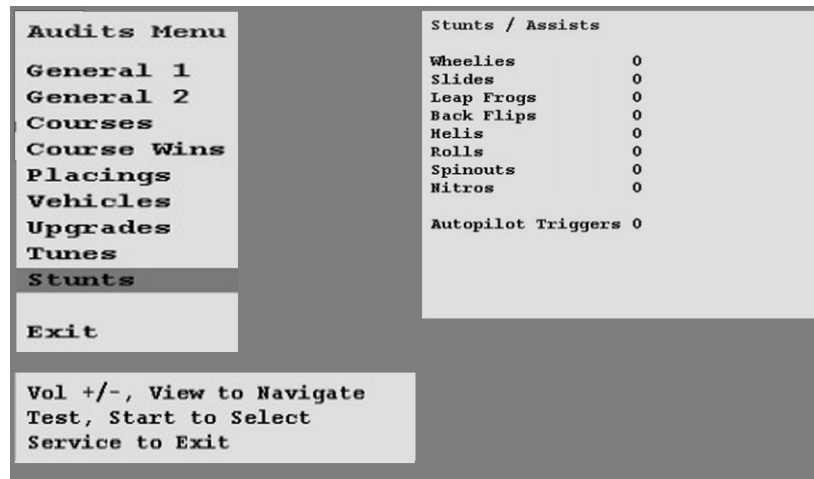

Adjustment Menu

From the **Main Menu**, select **Adjustment Menu** and enter. The Adjustment Menu allows you to customize the game. Each variable will change an aspect of the game play and appearance. Optimizing these settings should result in continued high player interest and game earnings. You can monitor the affects of these options by comparing audit information before and after the changes have been implemented. Press Start to Select. Use Shift lever or press Service to Exit.

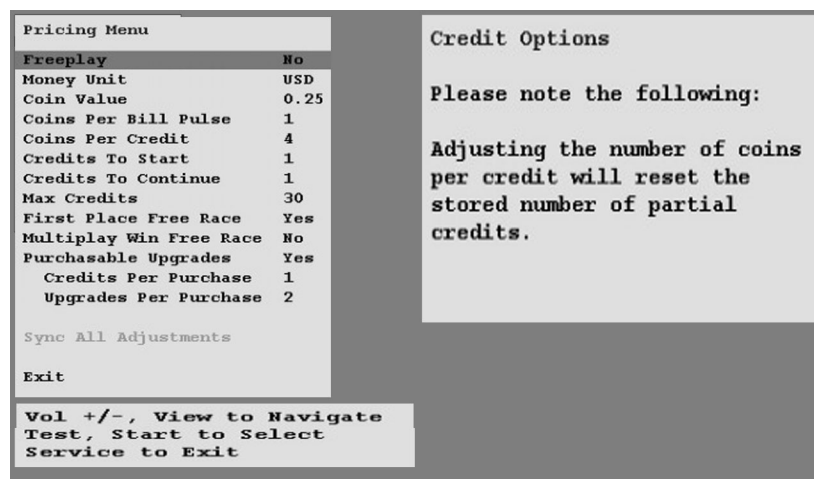

Price Menu

From the **Adjustment Menu**, select **Pricing** and enter. The Pricing Menu allows you to customize the pricing options and currency acceptor credit settings. Please note that if the acceptor is not present, the price setting will not have an effect on the game. Press Start to Select. Use Shift lever or press Service to Exit.

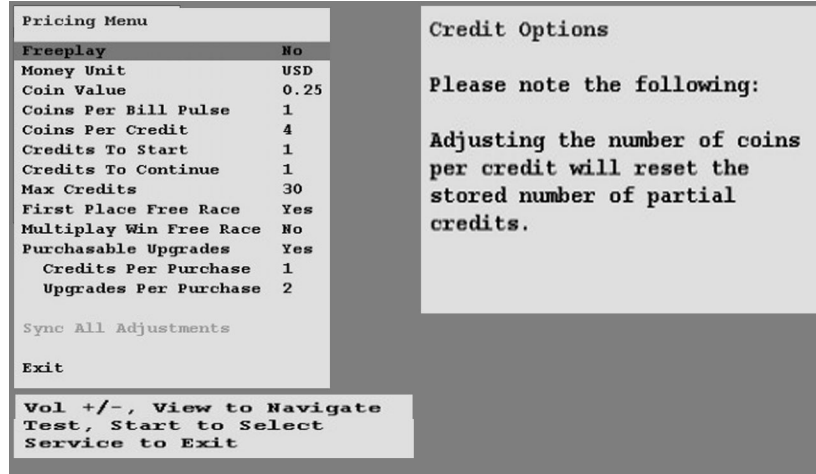

Free Play Menu

From the **Adjustment Menu**, select **Free Play** and enter. Select whether the game should be in Free Play Mode. In this mode, simply pressing the Start button can start a game. Press Start to Select. Use Shift lever or press Service to Exit.

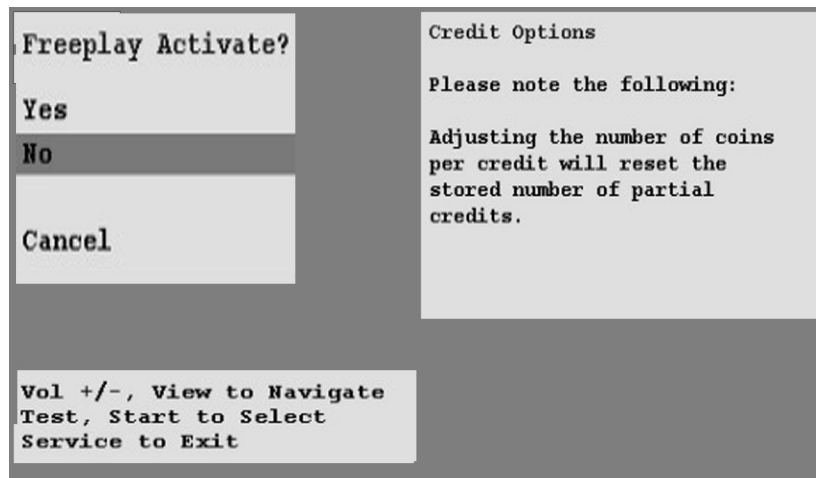

Money Unit Menu

From the **Pricing Menu**, select **Money Unit** and enter. Select the currency, which applies to the games location, and press Start to select. Press Start to Select. Use Shift lever or press Service to Exit.

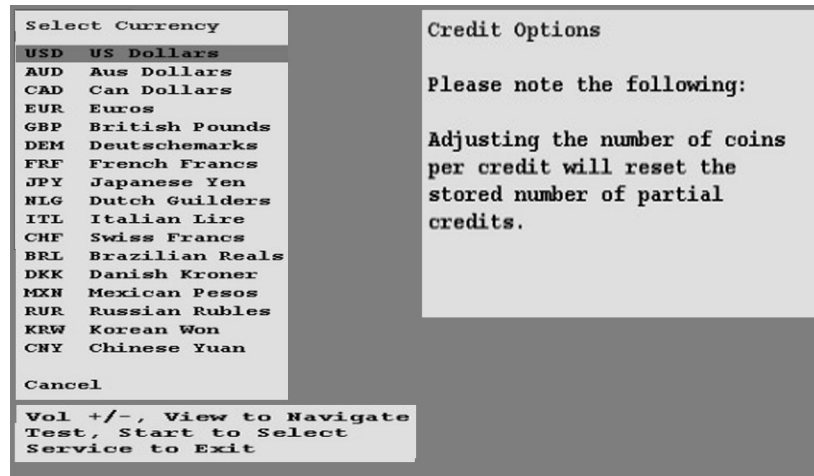

Coin Value Menu

From the **Pricing Menu**, select **Coin Value** and enter. Choose the coin value based on the currency selected and the coin acceptor type or setting. Press Start to Select. Use Shift lever or press Service to Exit.

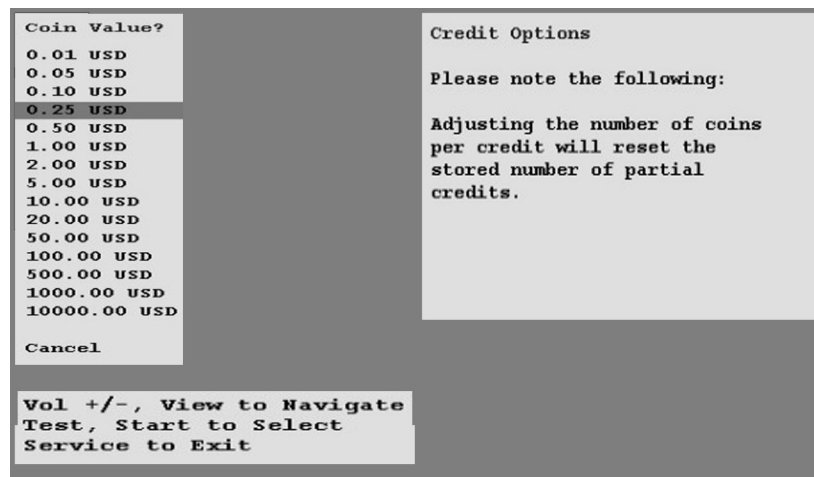

Coin Per Bill Pulse Menu

From the *Pricing Menu*, select *Coin per Bill Pulse Menu* and enter. Choose the equivalent coin value based on the bill acceptor currency type or settings. Press Start to Select. Use Shift lever or press Service to Exit.

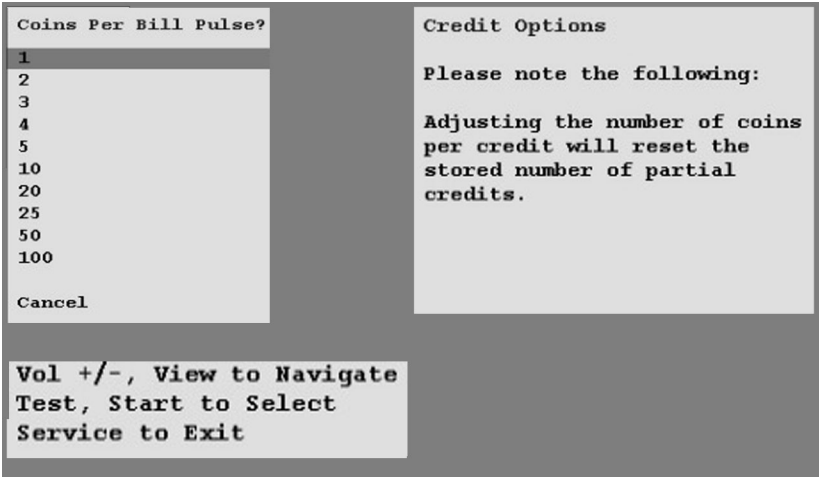

Coin Per Credit Menu

From the *Pricing Menu*, select *Coin per Credit Menu* and enter. Choose the number of coins required to earn one credit. One credit equals to one purchased game. Press Start to Select. Use Shift lever or press Service to Exit.

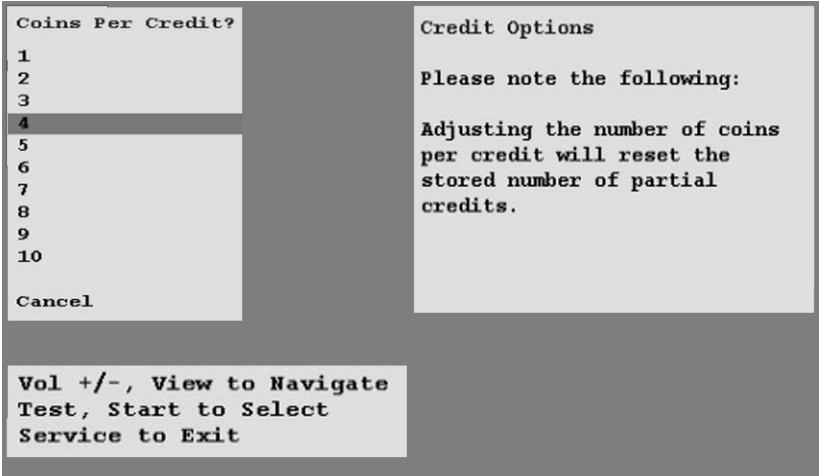

Credit To Start Menu

From the *Pricing Menu*, select *Credit To Start Menu* and enter. Choose the number of credits required to start one game. Press Start to Select. Use Shift lever or press Service to Exit.

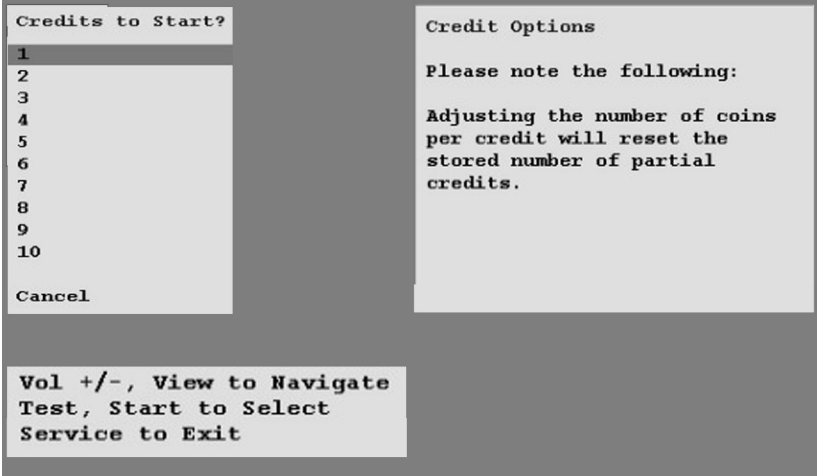

Coin Per Credit To Continue Menu

From the *Pricing Menu*, select *Credit To Continue Menu* and enter. Choose the number of credits required to continue from the current game. Press Start to Select. Use Shift lever or press Service to Exit.

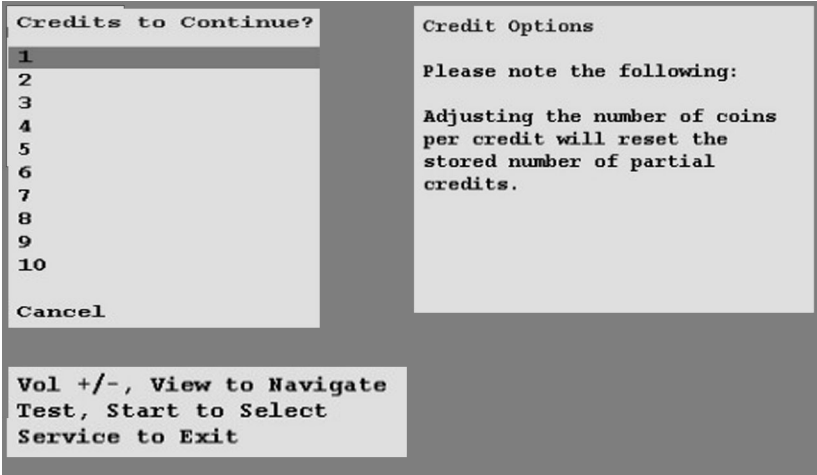

Max Credits Menu

From the *Adjustment Menu*, select **Max Credits** and enter. Press Start to Select. Press Tunes or Service to Exit.

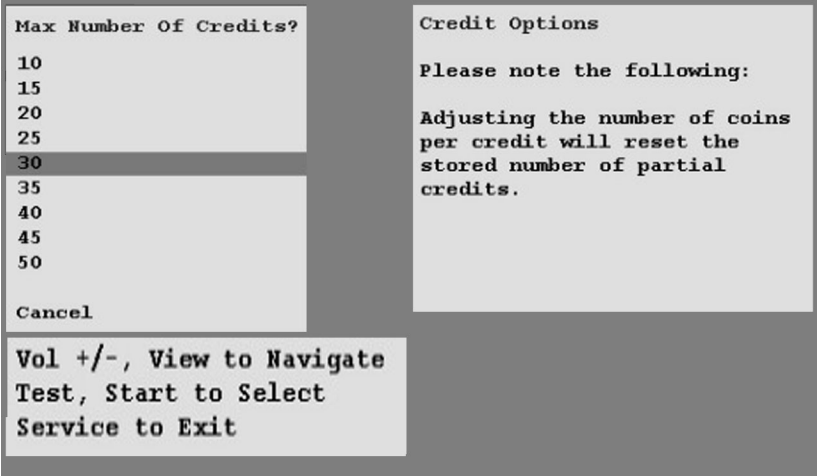

1st Place Free Race Menu

From the *Adjustment Menu*, select **1st Place Free Race** and enter. The player wins a free race for a 1st place overall finish during a single of networked race game. Press Start to Select. Use Shift lever or press Service to Exit.

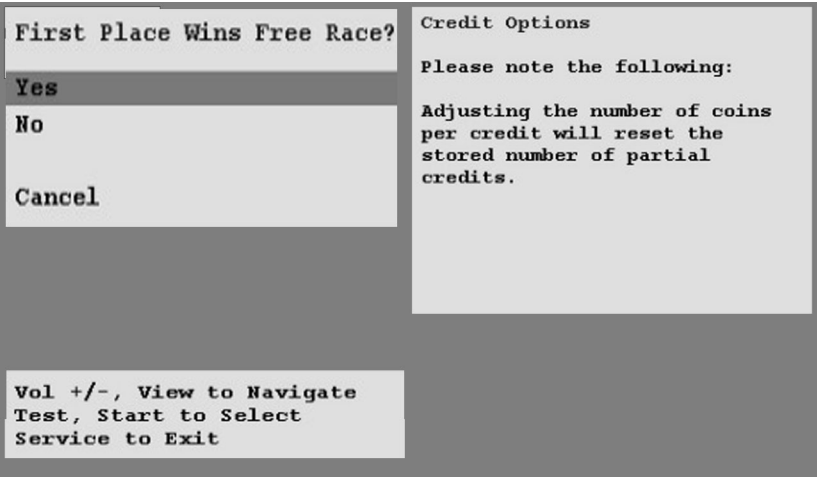

Multi-play wins free race

From the **Adjustment Menu**, select **Multiplay Win Gets Free Race** and enter. Winner of a networked game wins a free race if active. Default setting is No. Press Start to Select. Use Shift lever or press Service to Exit.

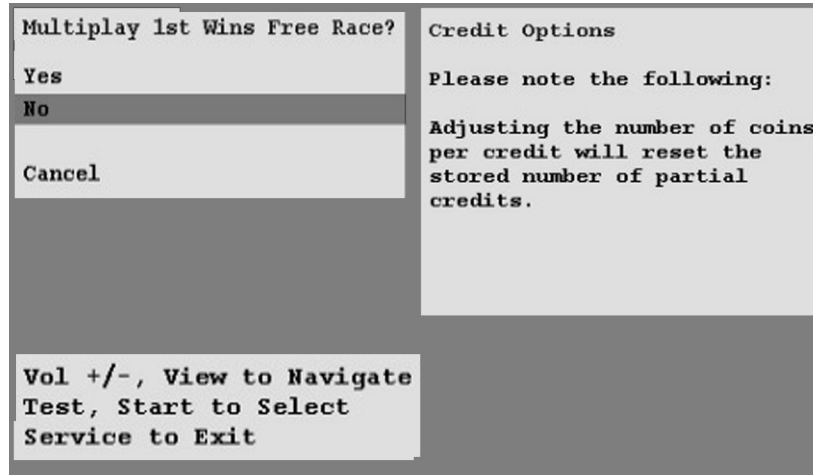

System Adjustment Menu

From the **Main Menu**, select **System Adjustment** and enter. Select whether audio is active while in attract mode. Press start to select. Use Shift lever or press Service to Exit.

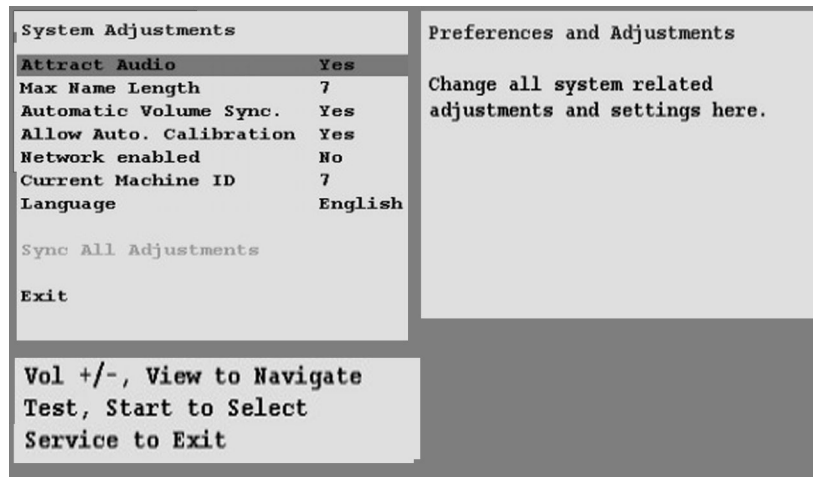

Attract Audio Menu

From the **System Adjustment** select **Attract Audio** and enter. Select whether audio is active while in attract mode. Press start to select. Use Shift lever or press Service to Exit.

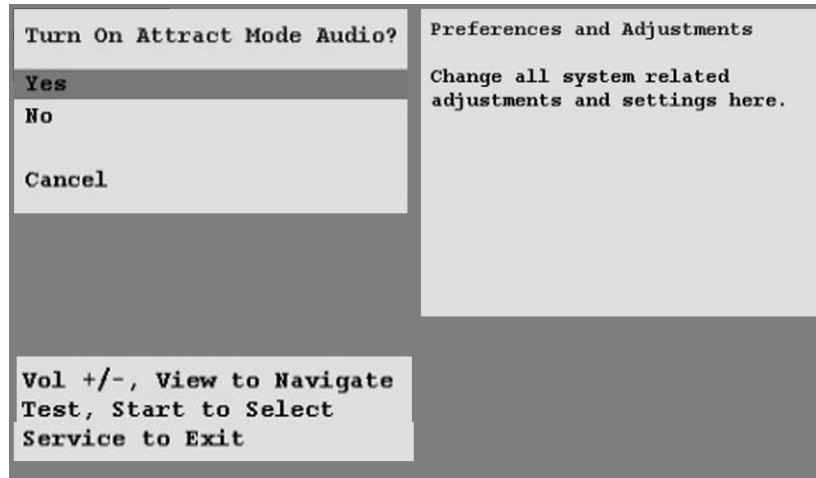

Max Name Length Menu

From the **System Adjustment Menu**, select **Max Name Length** and enter. This refers to the number of allowable characters when entering player names. Press Start to Select. Use Shift lever or press Service to Exit.

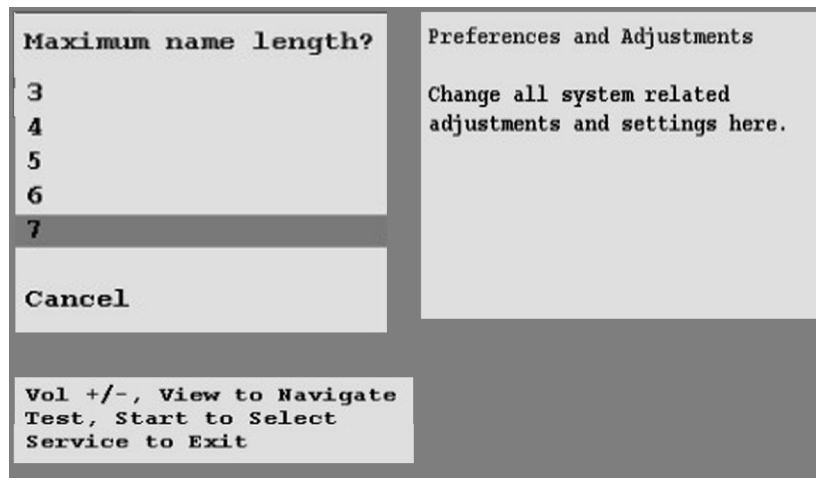

Automatic Volume Sync

From the **System Adjustments Menu**, select **Automatic Volume Sync** and enter. Select the amount of time in seconds given to the player to reach the first checkpoint. Press Start to Select. Use Shift lever or press Service to Exit.

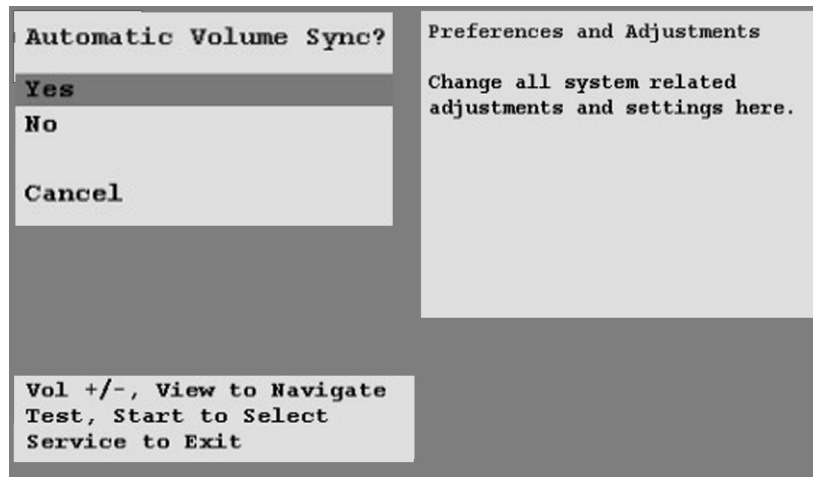

Automatic Volume Sync

From the **System Adjustments Menu**, select **Network Enabled** and enter. Select the YES to enable game linking feature, or NO to disable. Press Start to Select. Use Shift lever or press Service to Exit.

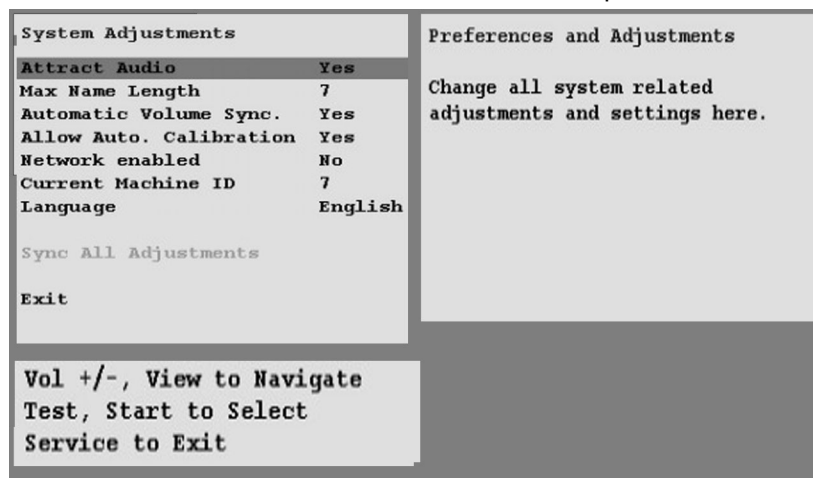

Current Machine ID

From the **System Adjustments Menu**, select **Current Machine ID** and enter. Select a unique ID number for each game in the network. It is important that each machine has a different ID number for proper operation. Press Start to Select. Use Shift lever or press Service to Exit.

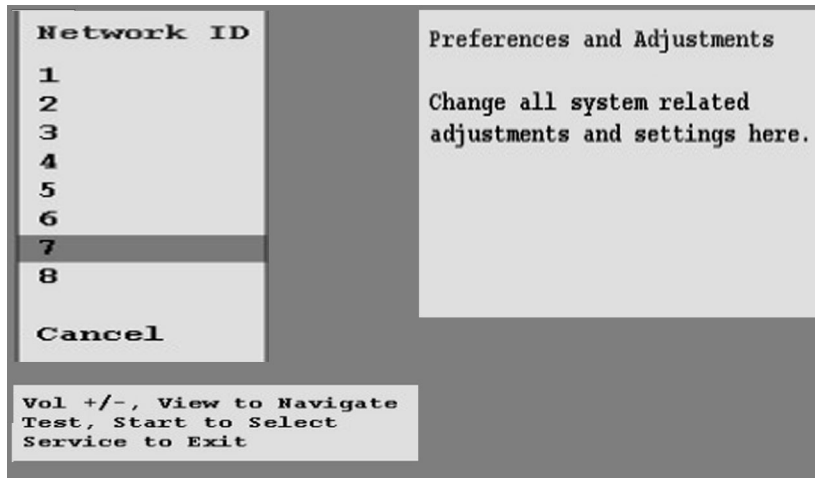

Language

From the **System Adjustments Menu**, select **Language** and enter. The default setting is English.

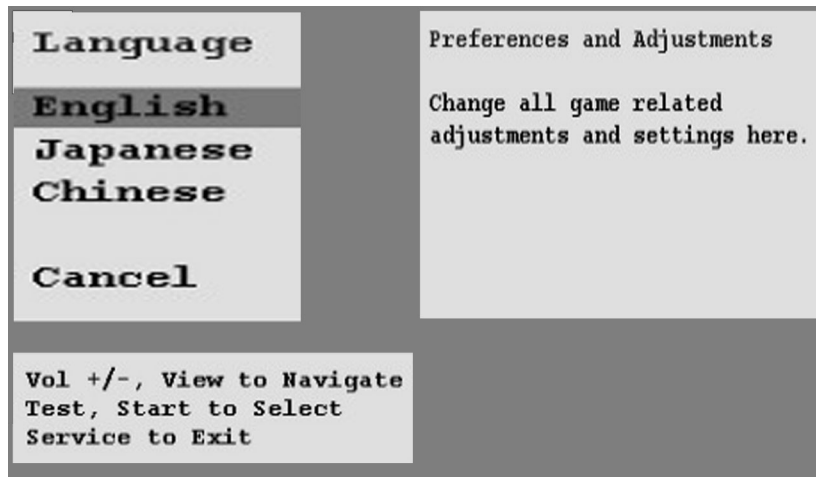

Start Time Bonus

From the **Game Adjustment Menu**, select **Start Time Bonus** and enter. Select the amount of time in seconds given to the player to reach the first checkpoint. Press Start to Select. Use Shift lever or press Service to Exit.

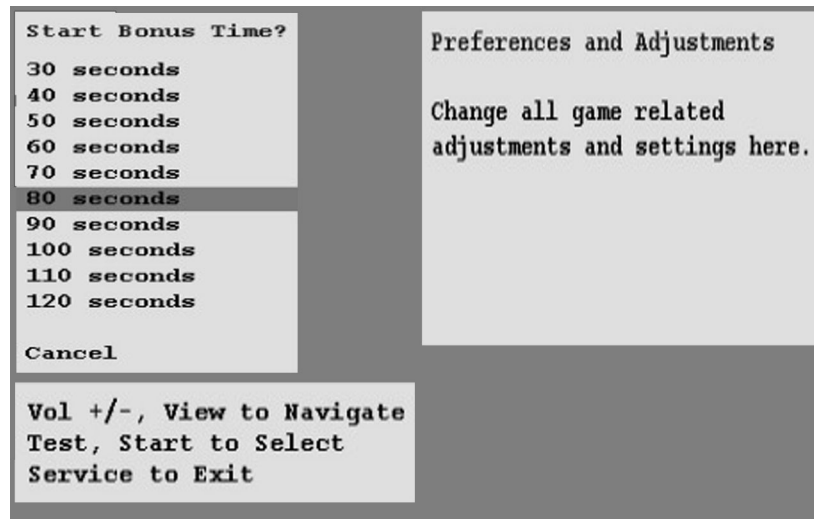

Checkpoint Time Bonus

From the **Game Adjustment Menu**, select **Checkpoint Time Bonus** and enter. Select the amount of time in seconds given to the player to reach the next checkpoint after the first checkpoint is reached. Press Start to select. Use Shift lever or press Service to Exit

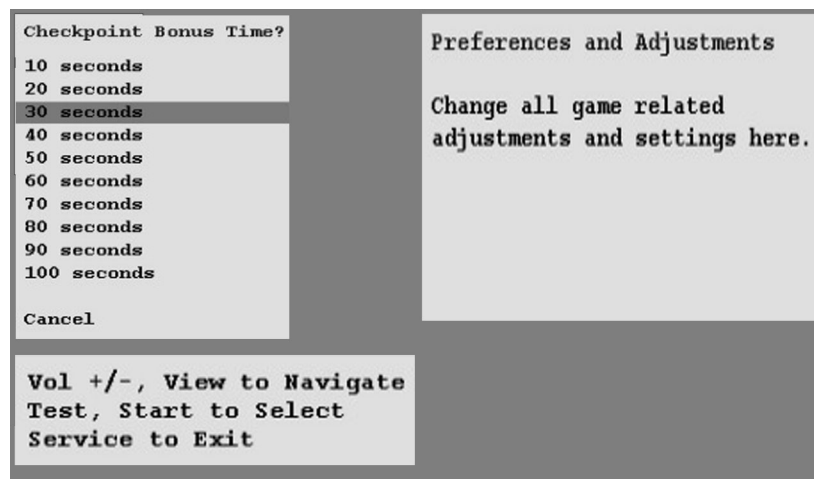

Game Difficulty Menu

From the **Game Adjustment Menu**, select **Game Difficulty** and enter. The default difficulty level is 5. Press Start to Select. Use Shift lever or press Service to Exit.

<p>Game Difficulty Level?</p> <p>1 Easier</p> <p>2</p> <p>3</p> <p>4</p> <p>5</p> <p>6</p> <p>7</p> <p>8</p> <p>9</p> <p>10 Harder</p> <p>Cancel</p>	<p>Preferences and Adjustments</p> <p>Change all game related adjustments and settings here.</p>	<p>Note:</p> <p>Please reference the game Audit information to determine the appropriate difficulty setting for your location. Compare changes in game statistics and game revenue before and after the change.</p>
<p>Vol +/-, View to Navigate Test, Start to Select Service to Exit</p>		

Speed Measurement Menu

From the **Game Adjustment Menu**, select **Speed Measurement** and enter. Select which unit is to be used to measure car speed. Choose MPH or Miles per Hour. Choose KPH or Kilometers per Hour. Press Start to Select. Use Shift lever or press Service to Exit.

<p>Speed Measured in...?</p> <p>MPH</p> <p>KPH</p> <p>Cancel</p>	<p>Preferences and Adjustments</p> <p>Change all game related adjustments and settings here.</p>
<p>Vol +/-, View to Navigate Test, Start to Select Service to Exit</p>	

Plays for Score Reset Menu

From the **Game Adjustment Menu**, select **Speed Measurement** and enter. This number represents the accumulated total number of games played before the high score table returns to default. Press Start to Select. Use Shift lever or press Service to Exit.

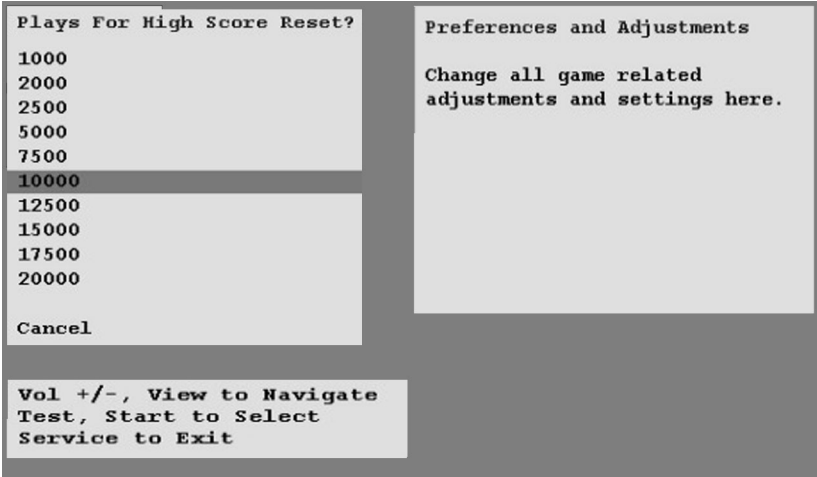

Auto Pilot Menu

From the **Adjustment Menu**, select **Auto Pilot Available** and enter. This feature activates after a certain amount of time has lapsed without the game controls being activated. Auto Pilot is a feature that allows the very young player who is not able to manipulate the controls, the ability experience the game. Press Start to Select. Use Shift lever or press Service to Exit.

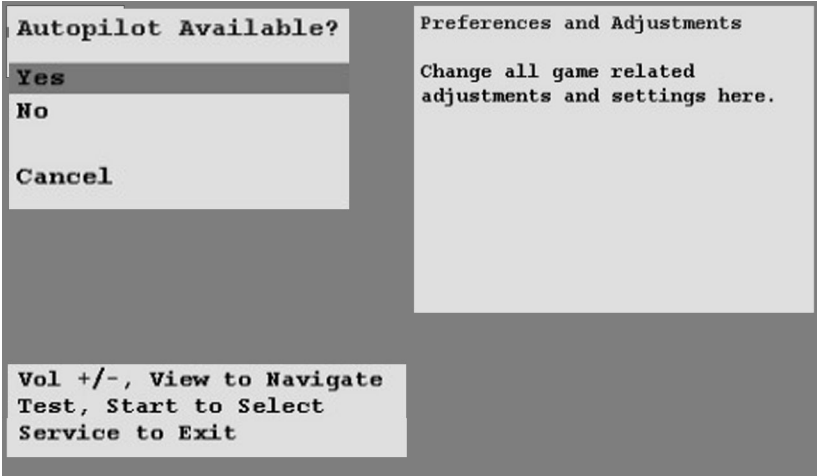

Girls and Crowds Enabled

From the **Game Adjustment Menu**, select **Girls and Crowd Enabled** and enter. For certain locations where the girls or crowds are not appropriate, it is possible to turn off both girls and crowd presence in the game. Select NO to turn off. The default setting is YES, or on. Press Start to Select. Use Shift lever or press Service to Exit.

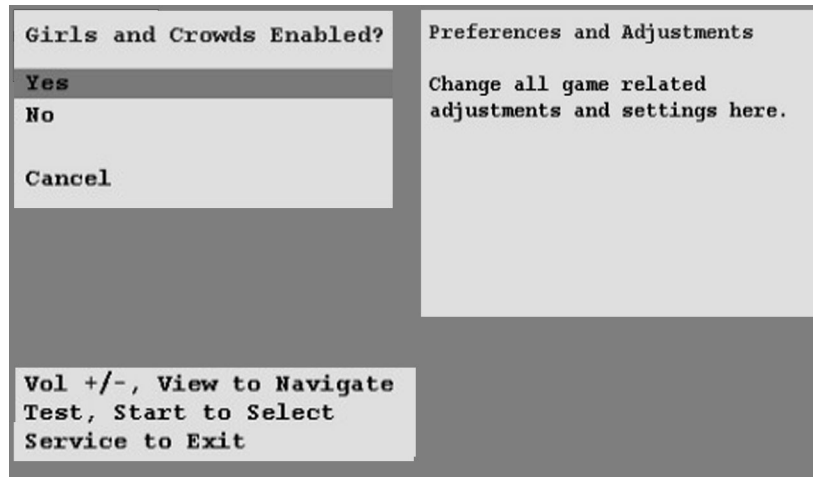

CRC Check Menu

From the **Utilities Menu**, select **CRC Check** and enter. Performing CRC check verifies the integrity of the software. Press Start to Select. Use Shift lever or press Service to Exit.

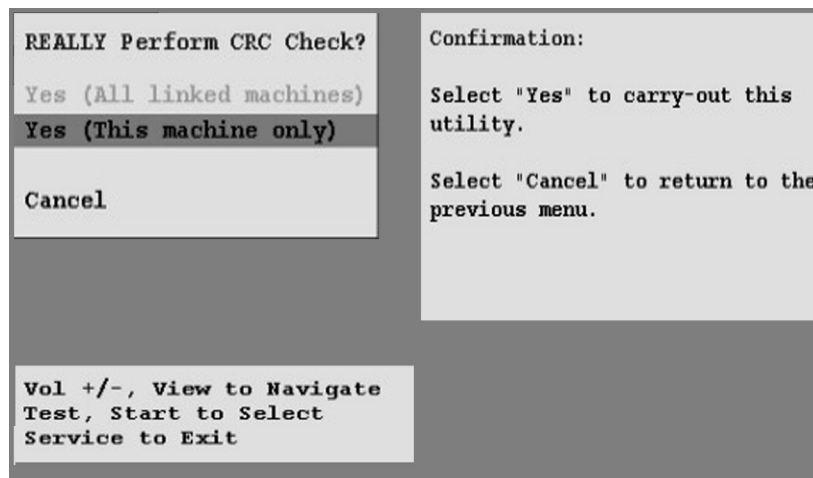

Clear Credit Menu

From the **Utilities Menu**, select **Clear Credits** and enter. Performing Clear Credit will delete any remaining credits posted. Press Start to Select. Use Shift lever or press Service to Exit.

Clear Audit Menu

From the **Utilities Menu**, select **Clear Audit** and enter. Performing Clear Audit will delete all audit information found on the Audit Menu. Please record them if you ever need to reference the information. Press Start to Select. Use Shift lever or press Service to Exit.

Clear High Scores Menu

From the **Utilities Menu**, select **Clear High Scores** and enter. Performing Clear High Score will clear the all high score tables. Press Start to Select. Use Shift lever or press Service to Exit.

Clear Player Stats Menu

From the **Utilities Menu**, select **Clear Player Stats** and enter. Performing Clear Player Stats will clear all player information, including PIN, car upgrades and money earned. Press Start to Select. Use Shift lever or press Service to Exit.

Default Adjustments Menu

From the **Utilities Menu**, select **Default Adjustment** and enter. Performing Default Adjustment setting will restore game adjustments back to its manufacturer recommended settings. The game will need to be re-calibrated. Press Start to Select. Use Shift lever or press Service to Exit.

Reset Link System Configuration

From the **Utilities Menu**, select **Speed Measurement** and enter. This number represents the accumulated total number of games played before the high score table returns to default. Press Start to Select. Use Shift lever or press Service to Exit.

Factory Restore Menu

From the **Utilities Menu**, select **Factory Restore** and enter. Performing Factory Restore will restore game adjustments back to its manufacturer recommended settings and clear all audit information. The game will need to be re-calibrated. Press Start to Select. Use Shift lever or press Service to Exit.

Note:

- Information will be permanently erased by Clear or Reset functions.
- It is often ideal to perform a factory restore when the game is being moved to a new location.
- Record your game audit information if performing any of the above functions.

Calibration Menu

From the **Test Main Menu**, select **Calibration** and enter. Making sure that the seat and Throttle are properly calibrated is the easiest way to make sure that your motorcycle game can maximize its earning potential. Follow the screen instructions carefully. Verify proper calibration on the Switch Test screen. Check and make sure that the minimum, center and maximum values correspond to the actual position of the control.

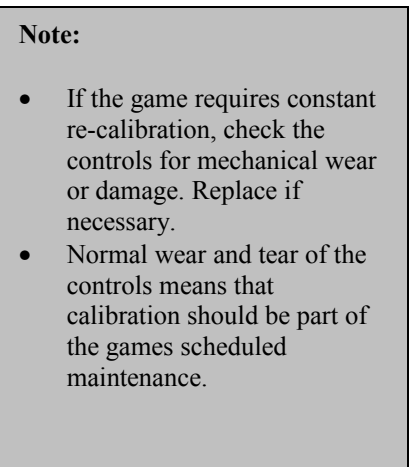
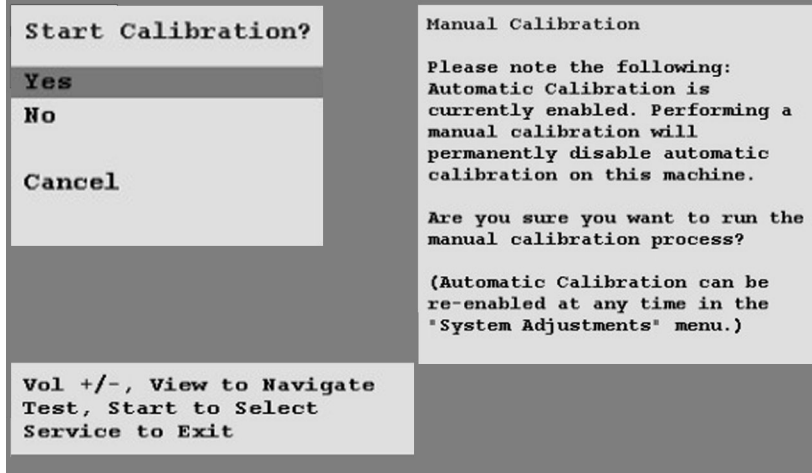

Volume Menu

From the **Test Main Menu**, select **Volume** and enter. This refers to the game volume while in play. Use the Volume Up/ Volume Down button on the service panel to adjust volume level. Press Start to Select. Use Shift lever or press Service to Exit.

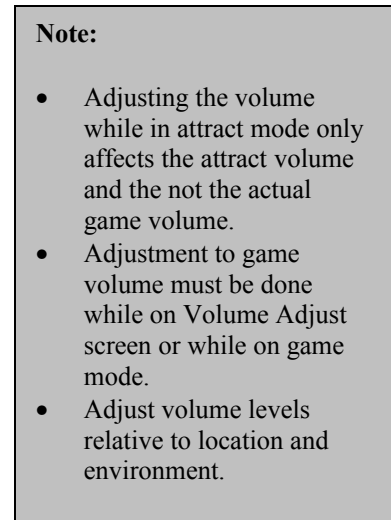
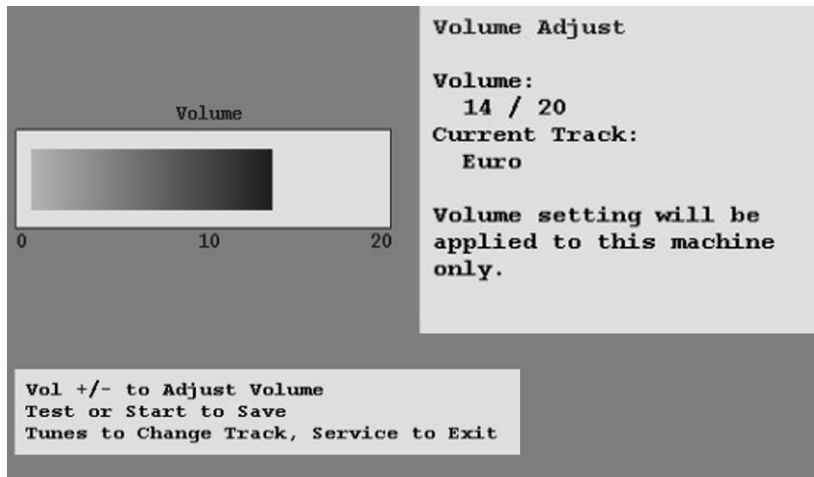

Attract Volume Menu

From the **Test Main Menu**, select **Attract Volume** and enter. This refers to the attraction volume while in standby(not in play). Use the Volume Up/ Volume Down button on the service panel to adjust volume level. Press Start to Select. Use Shift lever or press Service to Exit.

TROUBLESHOOTING GUIDE

PROBLEM	POSSIBLE CAUSE	SOLUTION
Game will not power up	Game not plugged in.	Plug game into receptacle.
	Game not turned on.	Turn ON main power switch
	Game fuse is blown	Check game fuse.
	No power to receptacle.	Plug game into powered receptacle.
	PC power switch is OFF	Turn PC power switch ON.
	PC BIOS set wrong.	See Appendix B.
“No Signal” Message	Video cables not secure.	Check and secure video connector.
	PC not turned ON.	Turn ON power to PC.
No video display.	No power to video display.	Check power to video display.
		see <i>Game will not power up.</i>
No sound.	Audio cable not connected.	Check audio cable connection.
	Speaker not connected.	Check speaker connection.
“I/O Board Missing”	USB connector not connected.	Check USB connector from PC to I/O board. Perform Hard Drive Recovery
	Bad game power supply	Check for proper connection and voltage to i/o board. Replace cabinet power supply.
Game will not load.	New Hard Drive installed.	Power cycle by un-plugging game. Perform Hard Drive Recovery
	Hard Drive data corrupted.	Perform Hard Drive Recovery.
Game Freezes	Secure Dongle Loose	Secure and Tighten Dongle
	Poor Ventilation	Check Fan Operation and Airflow
	USB cable loose	Remove and Reinsert USB both ends of cable
	Failing or Bad Power Supply	Check Power Supply Output or Replace With Known Good.
	Corrupted Hard Drive	Perform CRC Check. Re-Image if bad.
Game resets.	Low DC voltage.	Check for proper voltage(+5V,+12V)
	Door lamp is wrong rating.	Use only 5volt lamps.
	Cabinet/PC temperature is too high.	Check that vents and fans are functioning and not obstructed.
	Hard Drive data corrupted.	Perform Hard Drive Recovery..
Not Linking	DIP Switch Set Wrong	Refer to Networking Setup Section.
	Networking setting conflict.	Check Networking is ON and ID are unique.
	Game Operator Settings Not The Same.	Make Sure All Settings Are The Same Between Linked Games
Bike Controls Not Working	Bike not securely mated to monitor cabinet.	Secure bike to monitor cabinet using all 4 screws.
	Bike is not level with monitor cabinet	Move game to level surface or adjust leg leveler height as needed.
	Steering potentiometer Is loose	Secure connector firmly into potentiometer.
	Bad or Loose switch	Open fairing to access switches. Verify that switch and connections are good.
	Possible bad I/O board	Swap or replace I/O board
LEDs not responding (Speedometer, Brake, Tailpipes LEDs)	DB9 connectors on PC not secure.	Check DB9 connection and see items under “Bike Controls Not Working” of the Troubleshooting Section(above)
		Swap or replace speedometer board. Power Cycle Game.

Warning: Do not connect or disconnect any cables or connectors on this game with the power on. This could potentially damage the game.

Hard Drive Recovery

NOTICE: Fast and the Furious is shipped with a recovery compact disk. Hard drives have been known to occasionally fail for many reasons. Follow the procedure below to restore data on the hard drive if a disk failure should occur. Use extreme care when performing the following procedure and avoid rough handling of pc or DVD. Please check the Troubleshooting Guide section of this document. Have the recovery DVD ready before you begin.

The following are some symptoms, which may indicate a possible bad hard drive:

- Hard Drive Test reports “bad” or “missing” files. Please refer to Trouble Shooting section of the manual.
- The game fails to finish loading.
- A boot error is reported after game is power cycled or reset.
- The game is looking for a boot DVD to be inserted.
- Erratic game or attract mode.

Note: It is important that the USB cable from pc and power is connected to the I/O board before you proceed.

Hard Drive Recovery Procedure:

1. Open the control panel to access the pc.
2. Press the button on the DVD drive to open DVD tray.
3. Carefully insert the recovery disk into the tray.
4. Press the button on the DVD drive to close the DVD tray.
5. Turn OFF the pc by pressing the power button once.
6. Turn ON the pc by pressing the power button once.
7. Disk recovery process will begin automatically.
8. A message at the top of the screen will prompt you to remove the disk when process is over. Press the DVD drive button to open tray. Remove the recovery disk and store safely.
9. Turn OFF the pc by pressing the power button once.
10. Turn ON the pc by pressing the power button once.

Note: Do not interrupt power or reset the game during the following process!

11. The game will begin to initialize and load. It will typically take about five minutes to complete.
12. The hard drive recovery process is complete when the game enters attract mode.
13. Proceed with control calibration and make necessary game adjustments. Please refer to Setup and Test section of this manual.

-- End of Procedure--

SUPER BIKES 2



ELECTRONIC, MECHANICAL and PARTS
INFORMATION

PART DESCRIPTION	PART NUMBER
Computer- Dell Optiplex 740-SB2 w-Grphicsard	850-00012-01
eVGA Video Card GeForce GT240 1GB DDR3	600-00159-01
42" LCD Display MAKVISION	809-00004-01
RIO PCB- RAW THRILLS I/O	500-00040-01
SB2 decal cabinet left side	606-00522-01
SB2 decal cabinet right side	606-00523-01
SB2 decal cabinet front side	606-00524-01
SB2 marquee translite	606-00521-01
SB2 BIKE Decal Sheet (6 PCS BIKE & FAIRING)	606-00518-01
SB2 SKIRT DECAL - RECT RIGHT	606-00509-01
SB2 SKIRT DECAL - CIRC RIGHT	606-00510-01
SB2 SKIRT DECAL - RECT LEFT	606-00511-01
SB2 SKIRT DECAL - CIRC LEFT	606-00512-01
SB2 LEFT FAIRING DECAL	606-00516-01
SB2 RIGHT FAIRING DECAL	606-00517-01
SB2 - CAUTION STAND BACK - T-base Sticker	606-00519-01
SB2-42 MONITOR FRAME DECAL	606-00520-01
SB2 - REAR BIKE MARQUEE	606-00508-01
SB2 Bike Sticker Left	606-00531-01
SB2 Bike Sticker Right	606-00532-01
SB2 Lower Bike Sticker Left	606-00533-01
SB2 Lower Bike Sticker Right	606-00534-01
SB2 Tailpipe Sticker Left	606-00535-01
SB2 Tailpipe Sticker Right	606-00536-01
HARNESS: BIKE2 LED	810-00017-02
HARNESS: SB2 CONTROL PANEL	810-00018-02
HARNESS: SB2 MAIN HARNESS	810-00019-05
HARNESS: SB2 MARQUEE XFACE	810-00405-01
HARNESS: SB2 MARQUEE	810-00406-01
HARNESS: SB2 BIKE XFACE	810-00201-01
Blindmate Bracket- Female	600-00254-01
Blindmate Bracket- Male	600-00253-01

NOTE: FOR CONTINUED SAFETY AND PROPER OPERATION ALL EARTH GROUND CONNECTIONS MUST BE CONNECTED TO KNOWN GOOD GROUND PLANE.
ALL ACCESSIBLE METAL PARTS OF THE GAME MUST BE GROUNDED.

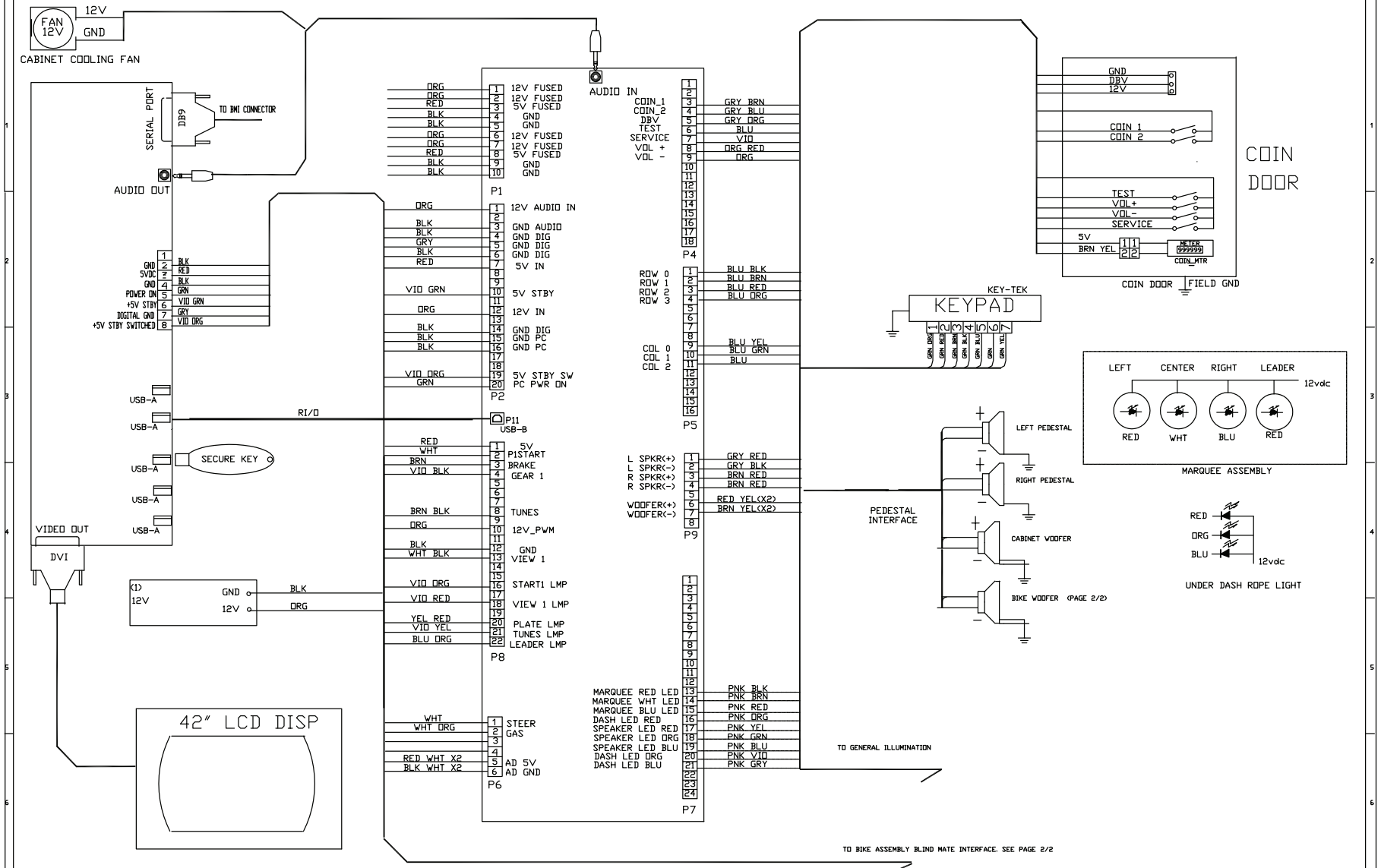

NOTE: FOR CONTINUED SAFETY AND PROPER OPERATION ALL EARTH GROUND CONNECTIONS MUST BE CONNECTED TO KNOWN GOOD GROUND PLANE.
ALL ACCESSIBLE METAL PARTS OF THE GAME MUST BE GROUNDED.

FROM
PAGE 1/2

BIKE ASSEMBLY

30 PDS. BLIND MATE CONN.

1	RED (18 AWG)
2	RED WHT
3	RED
4	WHT
5	BRN
6	WHT DRG
7	BLK WHT
8	BLK
9	VID RED
10	VID DRG
11	VID YEL
12	WHT BLK
13	VID BLK
14	BLK
15	BLK
16	YEL GRN
17	YEL BLU
18	YEL
19	RED YEL
20	BRN YEL
21	GRNYEL(18 AWG)
22	WHT BLK(18 AWG)
23	BLK WHT (18 AWG)
24	BLK (18 AWG)
25	
26	
27	
28	DRG
29	GRN WHT
30	

EARTH GROUND
- AC NEUTRAL
- AC VOLTAGE

WARNING:
DANGEROUS HIGH VOLTAGE PRESENT

GRNYEL(18 AWG)

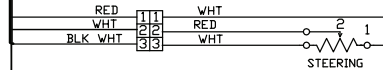
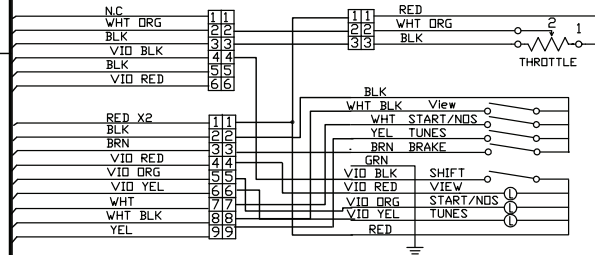
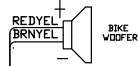

SPEEDO LED BRD



TAIL PIPE LED BRD

BRN BLK



TAIL PIPE LED BRD

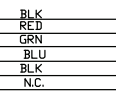

BRAKE LED BRD

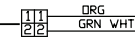
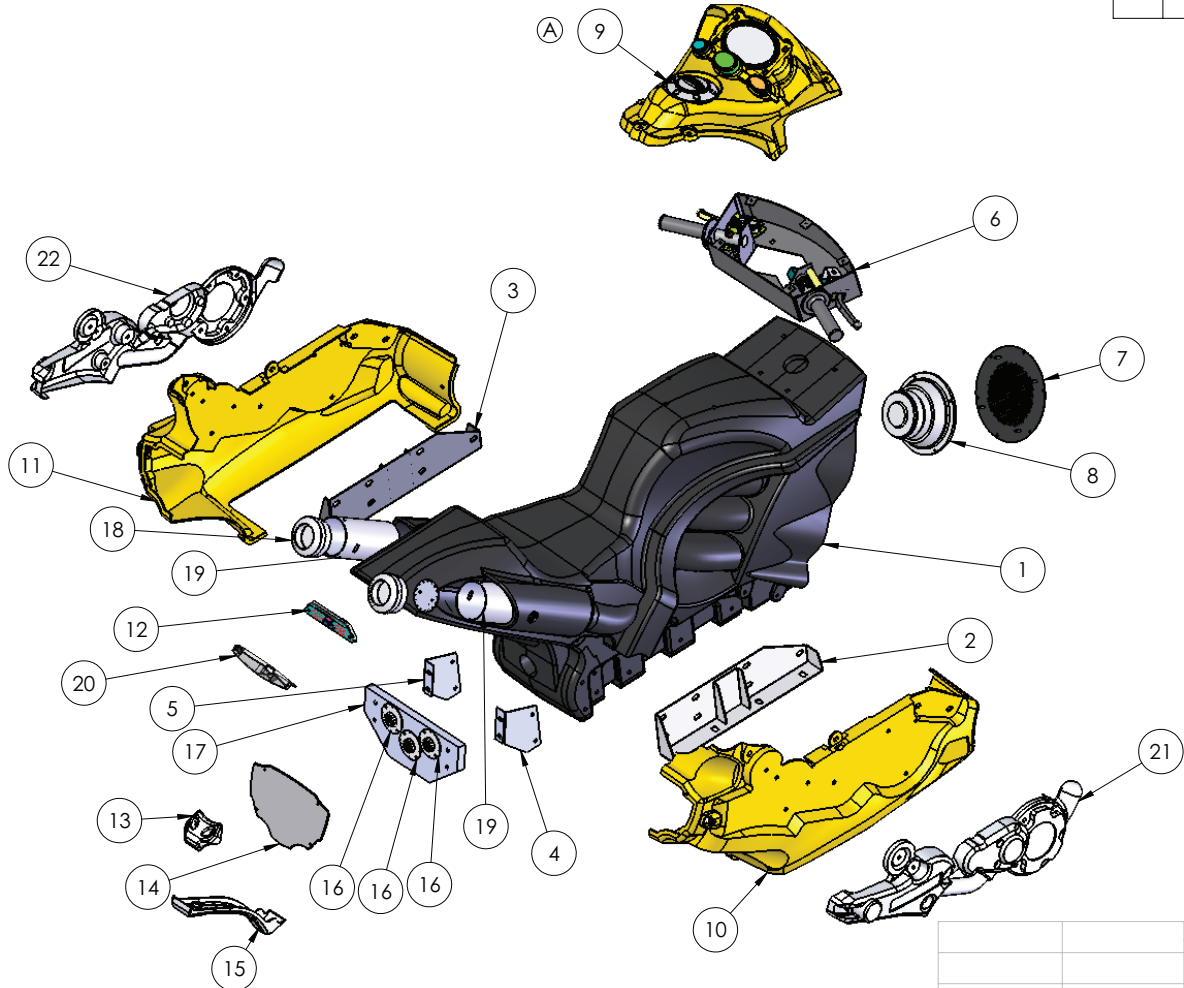

PLATE LED (X3)

SUPERBIKES 2 EXPLODED BIKE ASSEMBLY

REVISIONS				
ZONE	REV.	DESCRIPTION	DATE	APPROVED
	A	SHEET 2 FAIRING ASSEMBLY-NEW PART #603-00528-01 FOR YELLOW FAIRING REPLACING OLD # 603-00007-01.	9/21/2010	M DAVIS



BOM Table				
ITEM NO.	PART NUMBER	DESCRIPTION	SUPPLIER	QTY.
1	603-00004-01	Rotomolded Bike - As Built	RT	1
2	602-00002-00	BIKE MOUNTING BRACKET-RIGHT	CM	1
3	602-00001-00	BIKE MOUNTING BRACKET-LEFT	CM	1
4	600-00571-01	Rear LED Support (R)	CM	1
5	600-00572-01	Rear LED Support (L)	CM	1
6	604-00004-01	Superbikes Handlebar Mech	HAPP	1
7	600-00506-01	Superbikes 2-Bike Woofer Grill	CM	1
8	807-00003-00	Speaker 6.5in Woofer 8ohm	RT	1
(A) 9	SB-2_Fairing Assembly	Fairing Assembly	SEE SHEET 2	1
10	603-00500-01	SB-2 Right Skirt	RT-NPP	1
11	603-00501-01	SB-2 Left Skirt	RT-NPP	1
12	800-00014-01	Tail Light Assembly	SEE SHEET 2	1
13	603-00511-02	SB-2 Skirt Brace-Upper		1
14	606-00508-01	SB2- Rear Bike Marquee	RT-NGS	1
15	603-00512-02	SB-2 Skirt-Brace-Lower		1
16	500-00035-01	White LED Spotlight PCB	RT	3
17	601-00520-01	Rear LED Support Panel	CM-TLC	1
18	SB-2_Tail Cap Assembly	SB-2_Tail Pipe Assembly	SEE SHEET 2	2
19	608-00015-01	TAILPIPE	CM	2
20	603-00006-01	BRAKELIGHT COVER	RT-NPP	1
21	603-00502-02	SB-2 Right Skirt Insert		1
22	603-00503-02	SB-2 Left Skirt Insert		1

PROPRIETARY AND CONFIDENTIAL
 THE INFORMATION CONTAINED IN THIS DRAWING IS THE SOLE PROPERTY OF <INSERT COMPANY NAME HERE>. ANY REPRODUCTION IN PART OR AS A WHOLE WITHOUT THE WRITTEN PERMISSION OF <INSERT COMPANY NAME HERE> IS PROHIBITED.

UNLESS OTHERWISE SPECIFIED:		NAME	DATE
DIMENSIONS ARE IN INCHES			
TOLERANCES:			
FRACTIONAL: ±		DRAWN	
ANGULAR: MACH ± BEND ±		CHECKED	
TWO PLACE DECIMAL ±		ENG APPR.	
THREE PLACE DECIMAL ±		MFG APPR.	
INTERPRET GEOMETRIC TOLERANCING PER:		Q.A.	
MATERIAL		COMMENTS:	
FINISH			
NEXT ASSY	USED ON		
APPLICATION		DO NOT SCALE DRAWING	

RAW THRILLS, INC

TITLE: **SUPERBIKES 2 BIKE ASSEMBLY**

SIZE **B** DWG. NO. SuperBike2Assy REV **A**

SCALE: 1:32 WEIGHT: SHEET 1 OF 3

ITEM NO.	PART NUMBER	DESCRIPTION	QTY.
1	600-00016-01	Speedo Plexi	1
2	600-00006-01	SPEEDO BOARD	1
3	603-00007-01-PART	FAIRING	1
4	W10 WASHER	BLACK HARDWARE	8
5	F&F HOOP CAP 2	CAP WITH CHECKERED FLAGS (100)	1
6	8-32nylock	ZINC HARDWARE	4
7	702-00010-00	START-LG DIVALGRN HAPPS9-8001-83301874	1
8	702-00011-00	TUNES - SM DIVL DRG HAPPS9-8001-82226102	1
9	702-00009-00	VIEW - SM DIVL BLUE HAPPS9-600-822262133	1
10	#8-32 TORX-125	BLACK HARDWARE	4

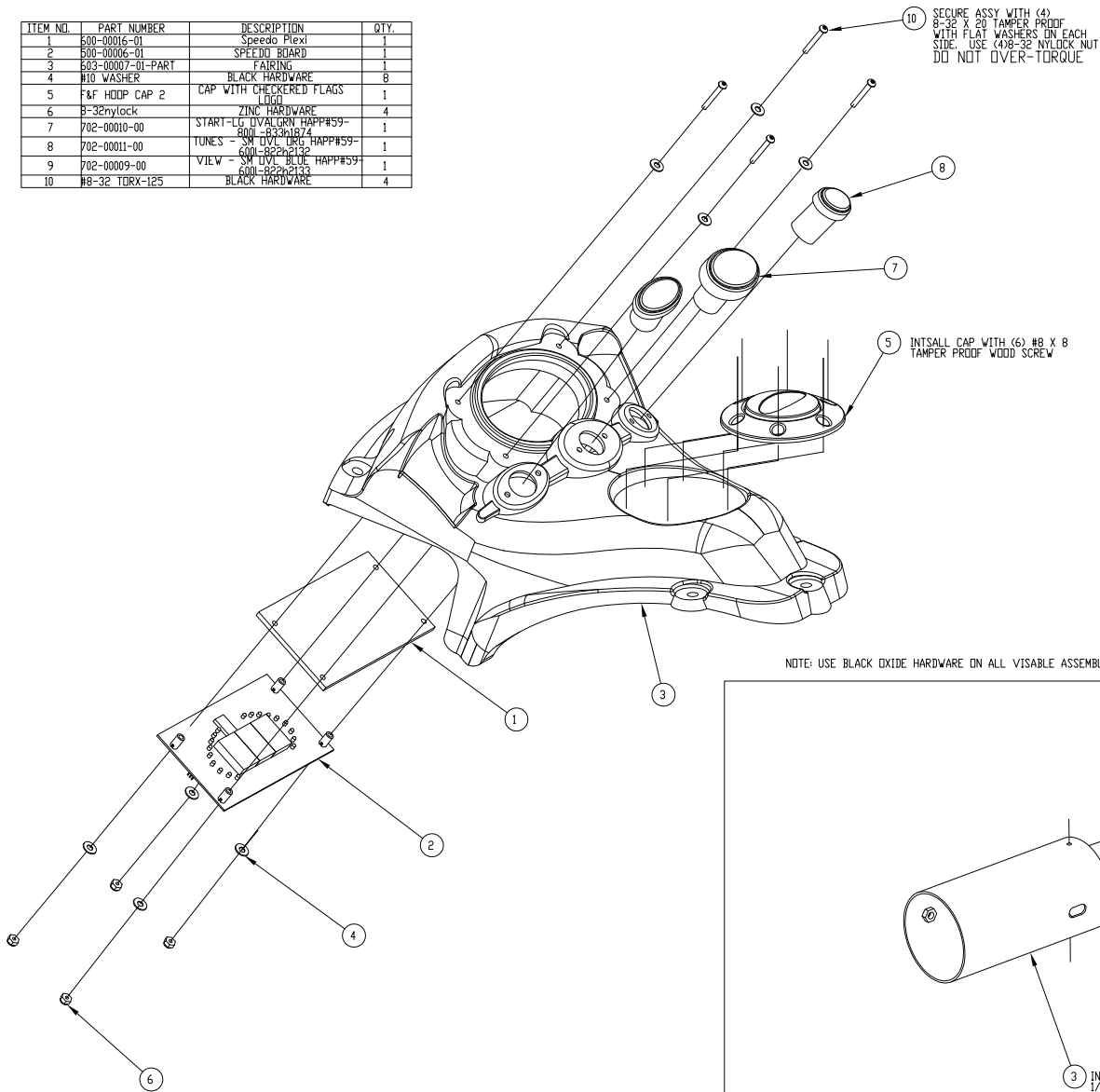

ITEM NO.	PART NUMBER	DESCRIPTION	QTY.
1	602-00006-00	TAIL LIGHT BRACKET	1
2	600-00005-01	BRAKE LED BOARD	1
3	#6-32 standoff-25	INSTALLED BY METAL FAB VENDOR	2
4	603-00006-01	BRACKET LIGHT COVER	1
5	#6-32x1/2in phillips hd screw		2

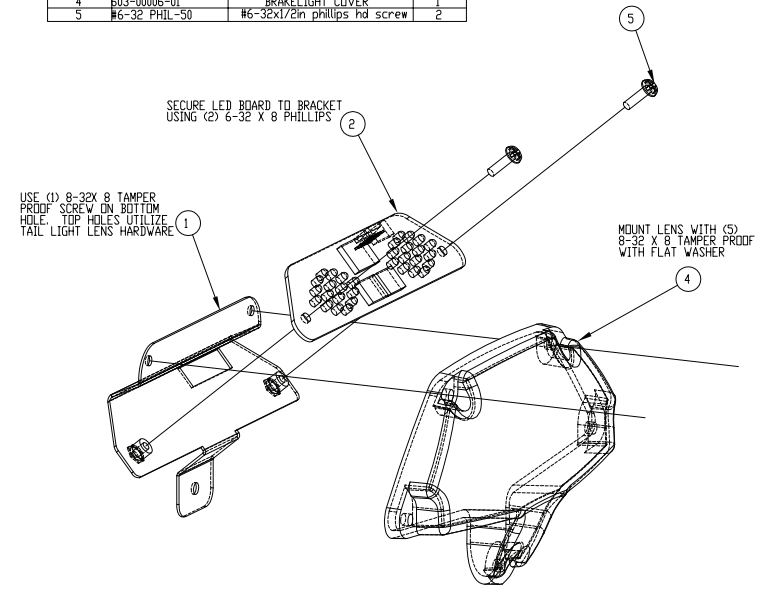

ITEM NO.	PART NUMBER	DESCRIPTION	QTY.
1	603-00005-01	TAILPIPE CAP	1
2	600-00004-01	Tailpipe LLD Board	1
3	608-00015-01	TAILPIPE	1

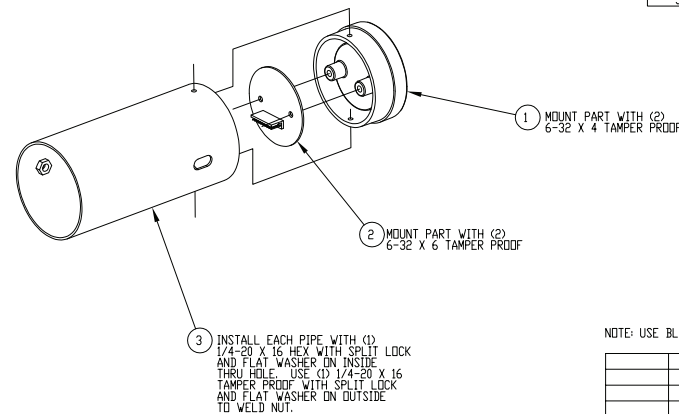

PROTECTIVE AND CONFIDENTIAL. THE INFORMATION CONTAINED ON THIS DRAWING IS TO BE USED FOR THE DESIGN AND CONSTRUCTION OF THE PARTS AND ASSEMBLIES SHOWN HEREON AND IS NOT TO BE REPRODUCED OR TRANSMITTED IN ANY FORM OR BY ANY MEANS WITHOUT THE WRITTEN PERMISSION OF HUNDT CORP. MAIL ROOM 10

NOTE: USE BLACK OXIDE HARDWARE ON ALL VISABLE ASSEMBLY

UNLESS OTHERWISE SPECIFIED	UNITS	DATE	TITLE
DRAWN			SUB-ASSEMBLY
CHECKED			
ENG APPR			
PLG APPR			
DATE			SIZE DWG. NO.
COMMENTS:			REV
INTERPRET GEOMETRIC TOLERANCING PER ASME Y14.5M-2009			WEIGHT:
DATE			SHEET 1 OF 1

8 7 6 5 4 3 2 1

REVISIONS				
ZONE	REV.	DESCRIPTION	DATE	APPROVED
	A	REPLACED 606-00126-01 WITH 606-00521-01.	7/22/2010	M DAVIS

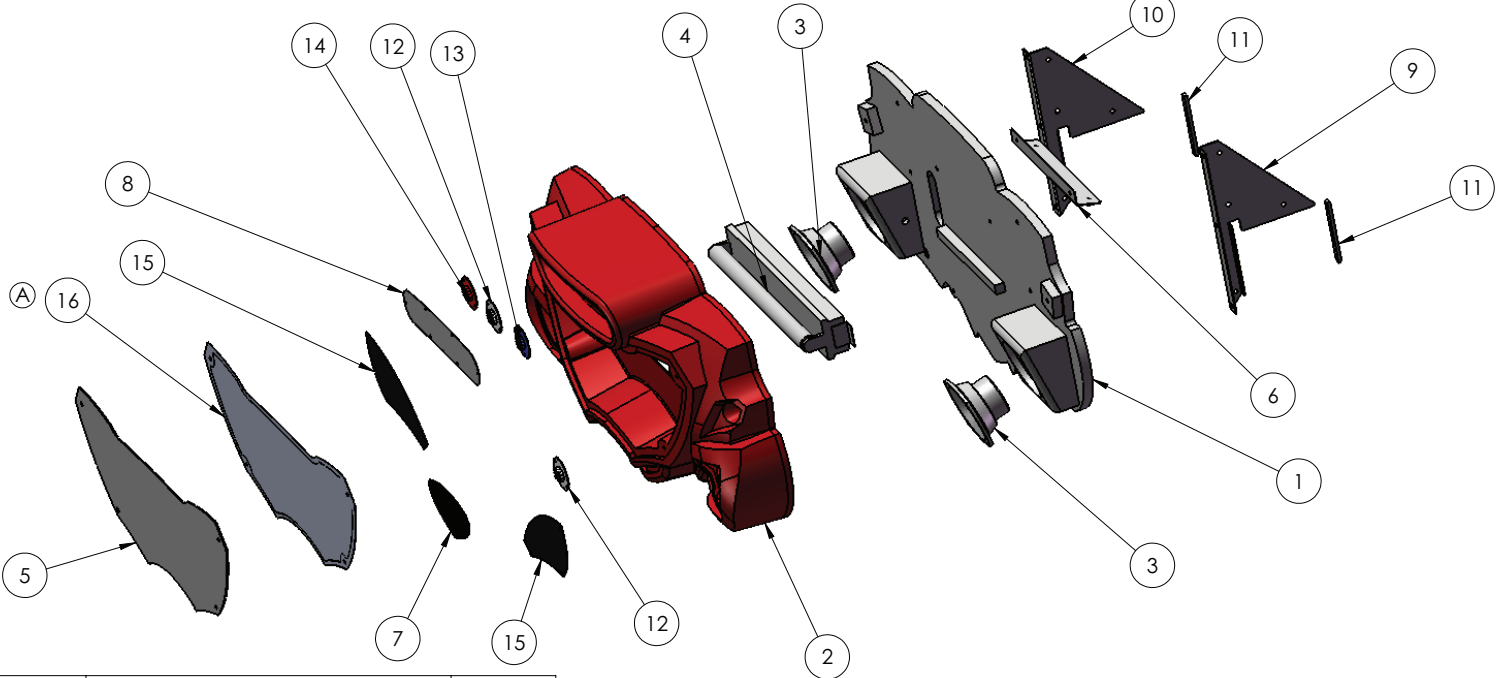

ITEM NO.	PART NUMBER	DESCRIPTION	QTY.
1	601-00051-01	Marquee Back Board	1
2	603-00504-01	SB-2 Marquee Plastic	1
3	2-1-10-00-00-000	5.25 Full Range Speaker	2
4	812-00004-01	18" Flourescent Assy 240V	1
5	606-00094-01	H2O Marquee Clear Display	1
6	600-00098-01	Marquee_Center_Bracket	1
7	600-00252-01	SB-2 Marquee Fan Grill	1
8	600-00092-01	H2O Marquee Blower Grill	1
9	600-00097-01	Marquee_back_bracket_Right	1
10	600-00096-01	Marquee_back_bracket_Left	1
11	Black Foam Tape	1/4T X 1/2W X 5L	2
12	500-00035-01	White LED Spotlight PCB	2
13	500-00028-02	BLUE LED Spotlight PCB	1
14	500-00026-02	RED LED Spotlight PCB	1
15	600-00093-01	H2O Marquee Speaker Grille	2
16	606-00521-01	SB2 Marquee Artwork	1

**SUPERBIKES 2 - 42 MARQUEE
EXPLODED ASSEMBLY**

PROPRIETARY AND CONFIDENTIAL
THE INFORMATION CONTAINED IN THIS DRAWING IS THE SOLE PROPERTY OF <INSERT COMPANY NAME HERE>. ANY REPRODUCTION IN PART OR AS A WHOLE WITHOUT THE WRITTEN PERMISSION OF <INSERT COMPANY NAME HERE> IS PROHIBITED.

		UNLESS OTHERWISE SPECIFIED:	NAME	DATE	RAW THRILLS, INC TITLE: SUPERBIKES 2-42 MARQUEE ASSY SIZE B DWG. NO. SB2-42Marquee_Assy REV A SCALE: 1:24 WEIGHT: SHEET 1 OF 1
		DIMENSIONS ARE IN INCHES	DRAWN		
		TOLERANCES:	CHECKED		
		FRACTIONAL: ±	ENG APPR.		
		ANGULAR: MACH ± BEND ±	MFG APPR.		
		TWO PLACE DECIMAL ±	Q.A.		
		THREE PLACE DECIMAL ±	COMMENTS:		
NEXT ASSY	USED ON	INTERPRET GEOMETRIC TOLERANCING PER:			
		MATERIAL			
		FINISH			
APPLICATION		DO NOT SCALE DRAWING			

8 7 6 5 4 3 2 1

(A)

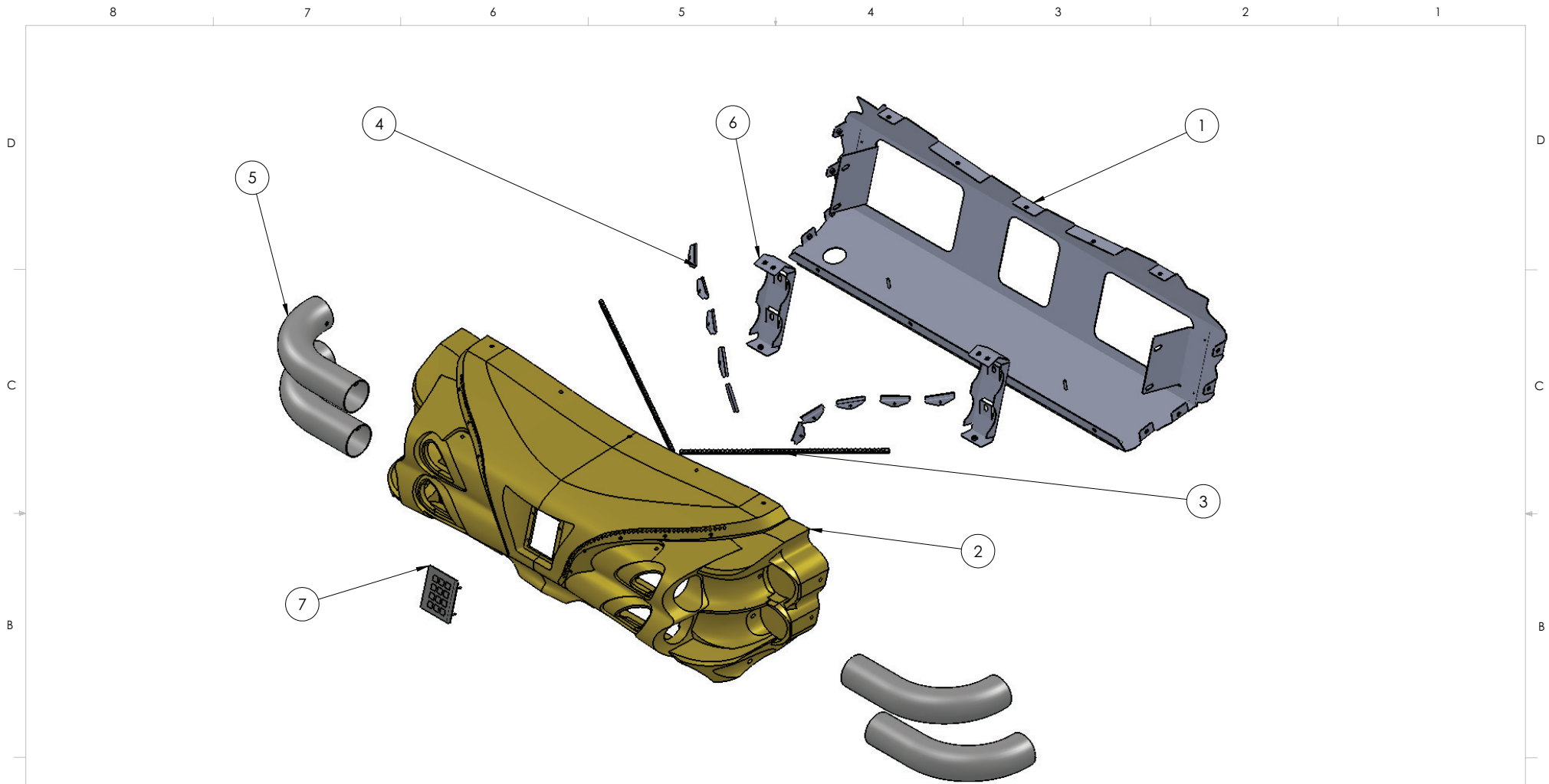

ITEM NO.	PART NUMBER	DESCRIPTION	QTY.
1	600-00249-01	SB2 Dash Mounting Bracket	1
2	603-00069-01	SB2 Dash - ABS	1
3	500-00034-01	45 LIGHT ROB LED STRIP	2
4	600-00570-01	SB2-42 LED_CLIP	10
5	608-00078-01	SB2 - 3" bent chrome tube	4
6	600-00514-01	SB-2 Pipe Bracket (2 req'd)	2
7	813-00006-01	Keypad- ATM Style Key-Tek	1

PROPRIETARY AND CONFIDENTIAL
 THE INFORMATION CONTAINED IN THIS DRAWING IS THE SOLE PROPERTY OF <INSERT COMPANY NAME HERE>. ANY REPRODUCTION IN PART OR AS A WHOLE WITHOUT THE WRITTEN PERMISSION OF <INSERT COMPANY NAME HERE> IS PROHIBITED.

		UNLESS OTHERWISE SPECIFIED:		NAME	DATE	RAW THRILLS, INC
		DIMENSIONS ARE IN INCHES TOLERANCES: FRACTIONAL: ± ANGULAR: MACH ± BEND ± TWO PLACE DECIMAL ± THREE PLACE DECIMAL ±				
		INTERPRET GEOMETRIC TOLERANCING PER:		Q.A.		SIZE DWG. NO. REV B SB-2-42_Dash_Assy
		MATERIAL		COMMENTS:		SCALE: 1:10 WEIGHT: SHEET 1 OF 1
		FINISH				
NEXT ASSY	USED ON					
APPLICATION		DO NOT SCALE DRAWING				

8

7

6

5

4

3

2

1

A

A

8 7 6 5 4 3 2 1

REVISIONS				
ZONE	REV.	DESCRIPTION	DATE	APPROVED
	A	DRAWING COMPLETED	12/14/2009	MJD
	B	ADDED ITEM #10- (FOAM TAPE) -TO DRAWING	8/17/2010	MJD

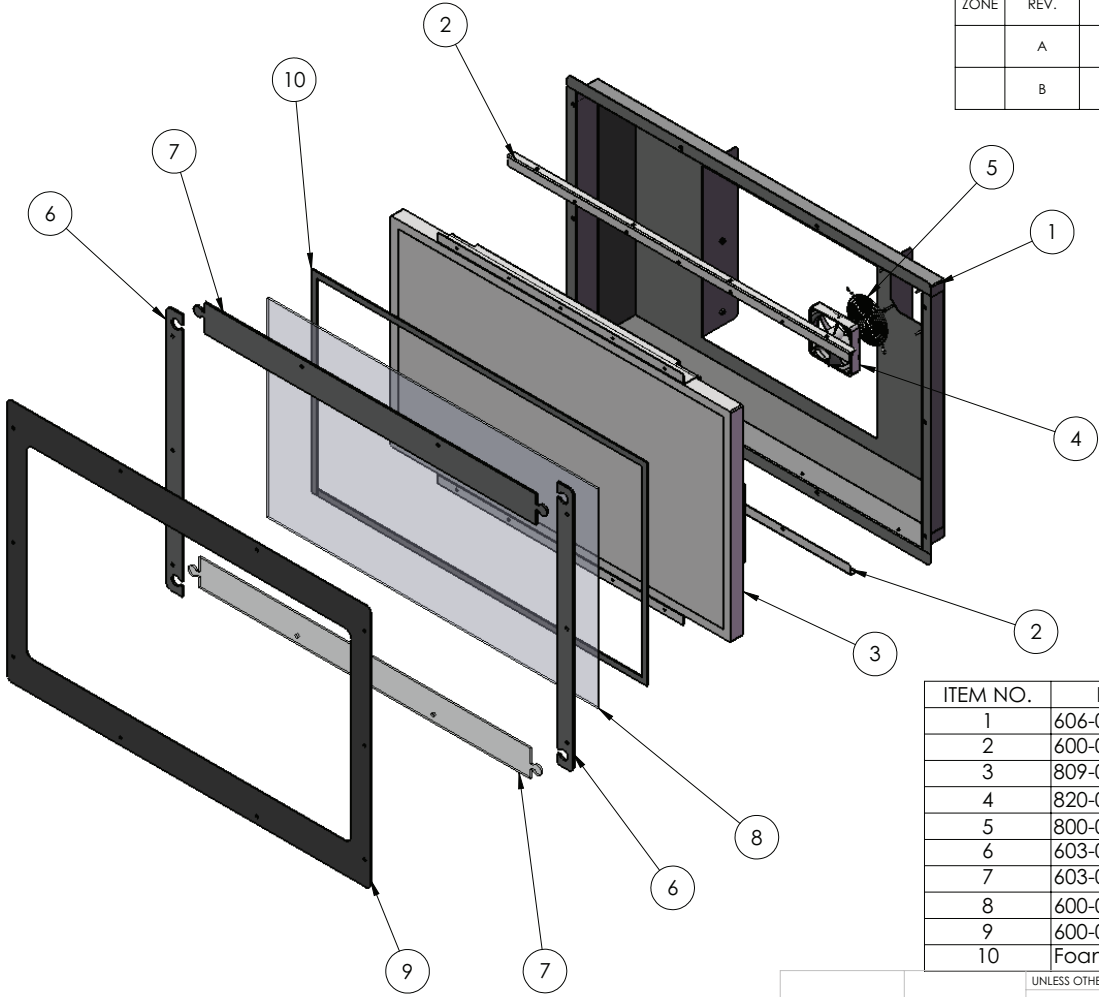

ITEM NO.	PART NUMBER	DESCRIPTION	QTY.
1	606-00097-01	42" LCD Beveled Box	1
2	600-00099-01	Internal Monitor Mounting Bracket	2
3	809-00004-01 ALLYSTAR	ALLYSTAR42XW01 LCD panel	1
4	820-00001-00	Fan, 120vac, 19/15W	1
5	800-00001-00	120mm Wire Fan Guard	1
6	603-00507-01	42" LCD Monitor Side Spacer	2
7	603-00506-01	42" LCD Top / Bottom Spacer	2
8	600-00509-01	SB-2, H2O 42" LCD Front Glass	1
9	600-00510-01	SB-2, H2O 42" LCD Metal Frame	1
10	Foamtape	5/8"W x 1/8"T black foam tape	1

D
C
B
A

D
C
B
A

8 7 6 5 4 3 2 1

PROPRIETARY AND CONFIDENTIAL
 THE INFORMATION CONTAINED IN THIS DRAWING IS THE SOLE PROPERTY OF <INSERT COMPANY NAME HERE>. ANY REPRODUCTION IN PART OR AS A WHOLE WITHOUT THE WRITTEN PERMISSION OF <INSERT COMPANY NAME HERE> IS PROHIBITED.

		UNLESS OTHERWISE SPECIFIED:	NAME	DATE
		DIMENSIONS ARE IN INCHES	DRAWN	
		TOLERANCES:	CHECKED	
		FRACTIONAL: ±	ENG APPR.	
		ANGULAR: MACH ± BEND ±	MFG APPR.	
		TWO PLACE DECIMAL ±	Q.A.	
		THREE PLACE DECIMAL ±	COMMENTS:	
		INTERPRET GEOMETRIC TOLERANCING PER:		
		MATERIAL		
		FINISH		
NEXT ASSY	USED ON			
APPLICATION	DO NOT SCALE DRAWING			

RAW THRILLS, INC
 TITLE:
SB-2 / H2O Monitor Assy

SIZE B	DWG. NO. 42-LCD-ASSY-H2-1Ally	REV B
SCALE: 1:24 WEIGHT:		SHEET 1 OF 1



TRADEMARK AND COPYRIGHT:

- **Kawasaki, KX450F, Ninja ZX-14, and Vulcan 2000 Classic are trademarks licensed by Kawasaki**
- **Motors Corp, USA, which does not manufacture or distribute this product. Consumer inquiries should be directed to Raw Thrills, Inc.**
- **Yamaha, the Tuning Fork Mark, R1 and likeness thereof including the color Yamaha Blue, Midnight Warrior and the likeness thereof, Star Logo, VMAX and the likeness thereof are trademarks of Yamaha Motor used under license.**
- **Streetfighter, Monster 1100, 1198S designs, marks and emblems are trademarks of Ducati Motor Holding S.p.A. and are used under license to Raw Thrills, Inc.**



Super Bikes 2 • Copyright 2010 • Raw Thrills Inc • All rights reserved.